

# Vital™ Navigation System with Navigation Array Kit for Brainlab®

Compatible with the Brainlab Spine and  
Trauma Navigation Software System

Surgical Technique Guide



 **ZimVie**

*Brainlab® is a registered trademark of Brainlab AG or an affiliated company.*

ZimVie SPINE SOLUTIONS



# Vital™ Navigation System with Navigation Array Kit for Brainlab®

The Vital Navigation System includes awls, probes, taps, and drivers that can be used in open or minimally invasive procedures for preparation and placement of Vital and Vitality screws. When used with the Navigation Array Kit, the Vital Navigation instruments are compatible with the Brainlab Navigation System.

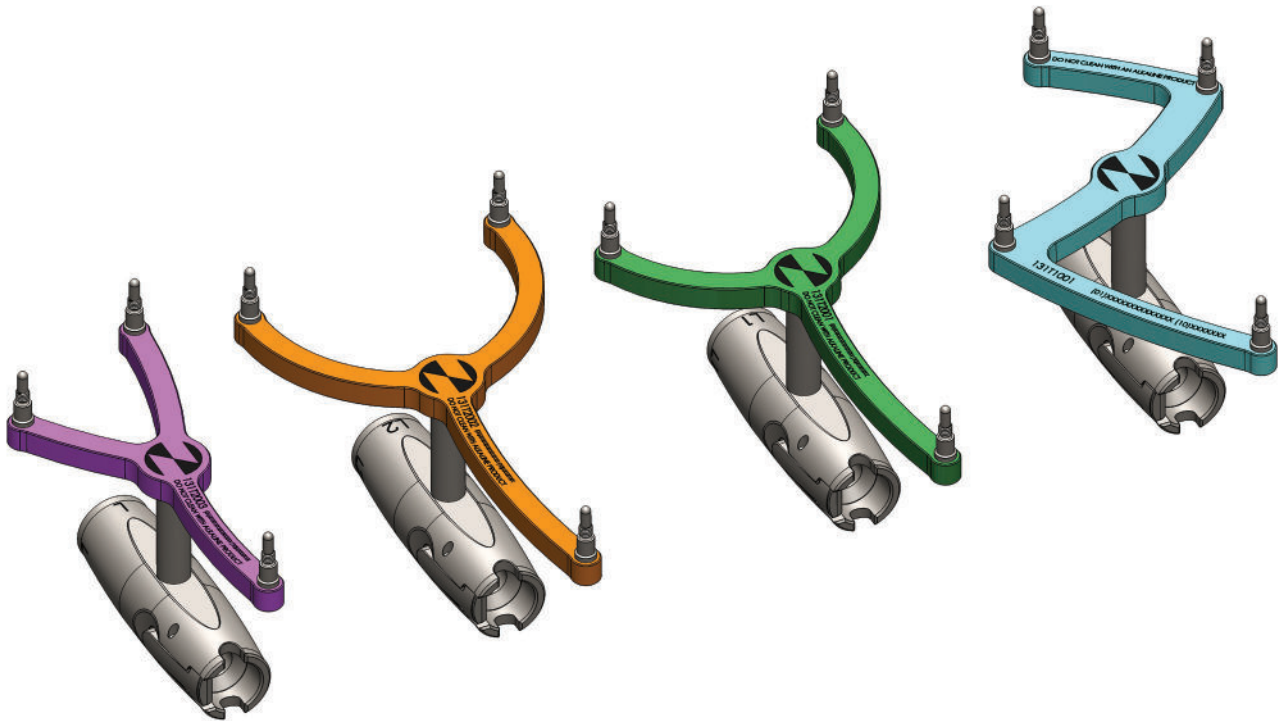

## Table Of Contents

Introduction and Key Features	4
Surgical Technique	6
Instruments	13
Reference Array Compatibility Chart with Vital Navigation Instruments	16
Important Information on the Vital Navigation System	17

ZimVie does not practice medicine. This technique was developed in conjunction with health care professionals. This document is intended for surgeons and is not intended for laypersons. Animations and virtual reality are provided as a visual guide based on surgical techniques. A written copy of the surgical technique is available at [www.zimvie.com](http://www.zimvie.com). Each surgeon should exercise his or her own independent judgment in the diagnosis and treatment of an individual patient, and this information does not purport to replace the comprehensive training surgeons have received. As with all surgical procedures, the technique used in each case will depend on the surgeon's medical judgment as the best treatment for each patient. Results will vary based on health, weight, activity and other variables. Not all patients are candidates for this product and/or procedure. Caution: Federal (USA) law restricts this device to sale by or on the order of a surgeon. Rx only.



# Introduction and Key Features

## Intended use:

The Vital Navigation system is a series of instruments that are designed to allow the navigation of bone preparation instruments and pedicle screws in the spine. When used with the ZimVie reference arrays, the Vital Navigation instruments can be used with the Brainlab Navigation System.

The Navigation Array Kit is a series of reference arrays that are compatible with the Vital Navigation System instrumentation to facilitate the navigation of bone preparation instruments and pedicle screws in the spine.

This surgical technique guide provides information on assembling the arrays to the navigation instruments and completing calibration activities with the Brainlab Spine and Trauma Navigation software. Users should follow instructions provided by the manufacturer of the navigation system used.

A manual technique can be used with any of the ZimVie screw system surgical technique guides in the event that the third-part-navigation is unavailable.

Refer to the following surgical technique guides, available at [labeling.zimvie.com](http://labeling.zimvie.com), for technical guiding principles for each system.

- Vital Spinal Fixation System
- Vital MIS Spinal Fixation System

**Note:** For information on using Vital Navigation with Medtronic StealthStation® S7 please review the Vital Navigation System for Medtronic StealthStation S7 Surgical Technique Guide.



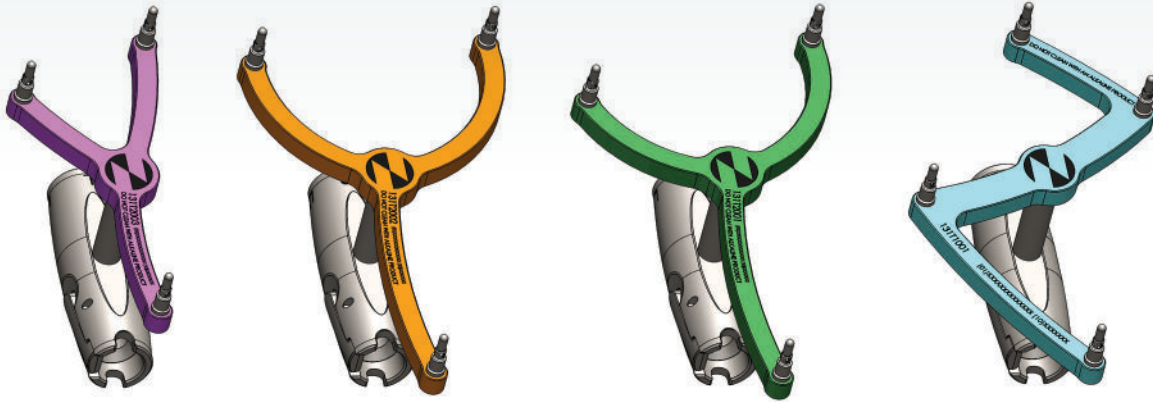

**Features and benefits include:**

- Suitable for a MIS or open approach
- Uninterrupted navigation facilitated by a freely-rotating adaptor
- Ergonomical design to facilitate the hand-held stabilization of the array relative to the instrument.
- Instruments provided in the Vital Navigation System are for bone preparation, tapping, and screw insertion.
- Nav PAT and Nav PASIT Styluses for use with the Vital MIS PAT Handle for MIS direct tapping or Direct-to-screw option.
- Compatible with Brainlab Spine & Trauma Navigation Software System

**Recommended Vital Navigation Arrays**

Recommended Array	Vital Navigation Instrument	Array Color
L	Awl	Magenta
4-Marker	Probes	Light Blue
L1	Taps and Pedicle Access Tool (PAT)	Green
L2	Drivers and Pedicle Access Screw Insertion Tool (PASIT)	Orange

**Note:** Do not use the L and 4-Marker arrays with Vital Navigation drivers.

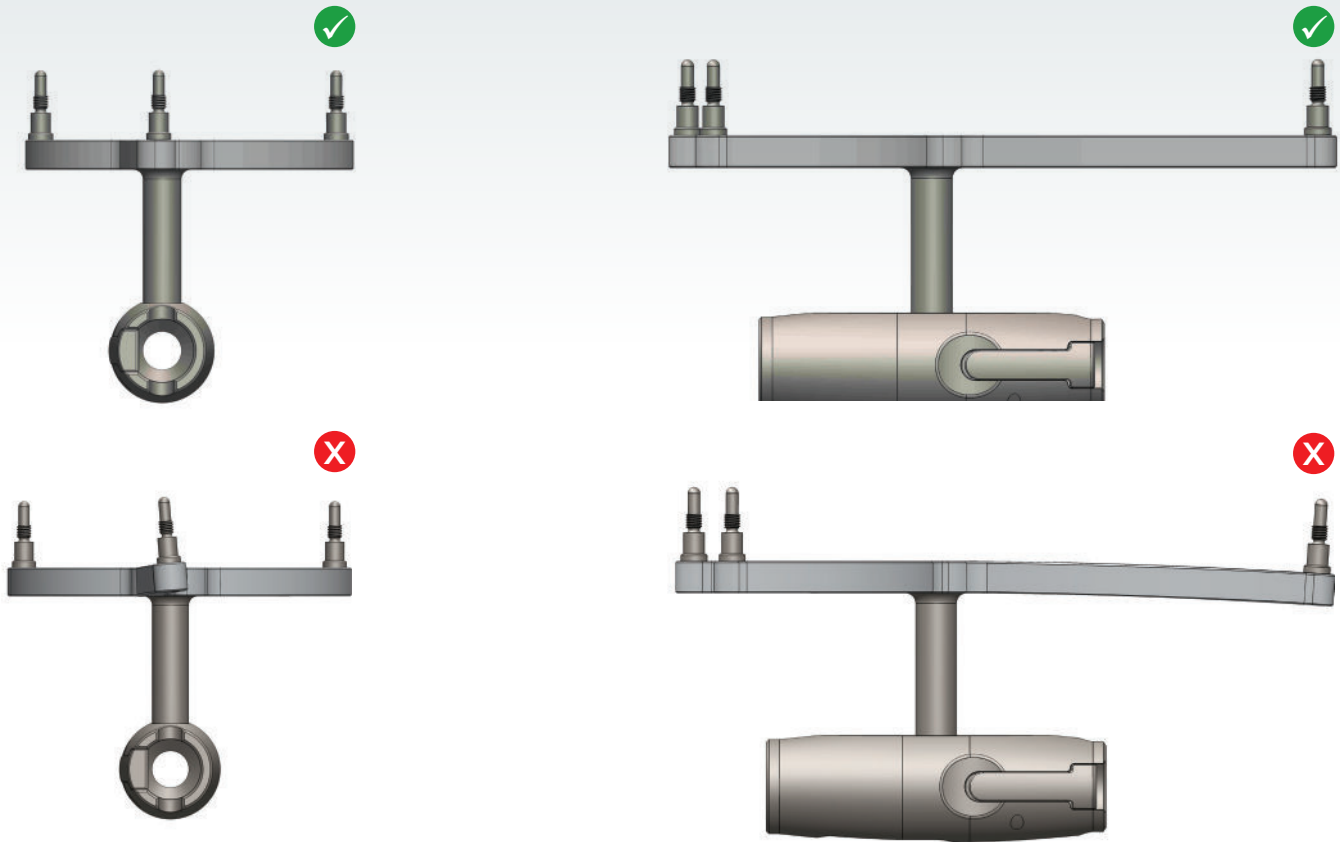
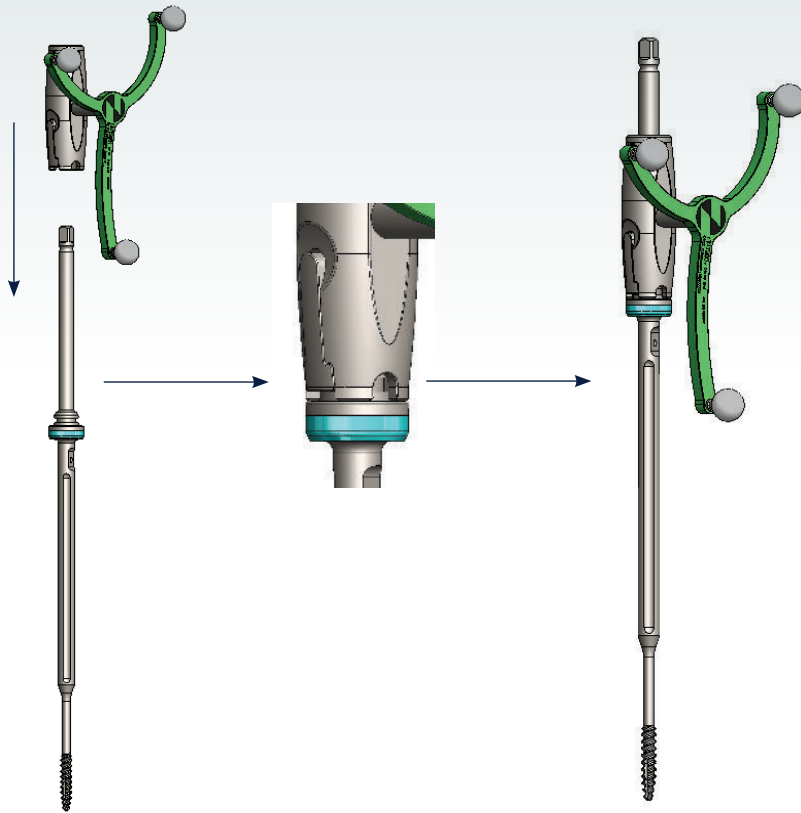

Figure 1

### Assembly

Prior to assembling an array with an instrument, make sure to inspect the entire array for bending, warping, or wear (Figure 1). The above images are examples of potential wear.

**Caution:** If an incident occurs that may have damaged an array, consult the Brainlab user guides to verify accuracy.



**Figure 2**

## Instrument Connection to Array

The arrays are compatible with the Vital Navigation System instruments.

1. Introduce the portion of the array with the locking button over the proximal end of the instrument.
2. Continue sliding the array over the proximal end of the instrument until it clicks and come to rest on the flange of the instrument.
3. After placing the array, any handle with a ¼ inch, square connection may be attached.
4. Attach the disposable reflective marker spheres to the array. Reference the Brainlab user guides for additional guidance.

**Note:** The array should move freely around the instrument. The free rotation of the array allows the reflective marker spheres to always face the camera while instruments are in use.

**Note:** The Brainlab PAN Tool can be used to install the Vital guide wires.

**Note:** To disassemble the array from the instrument, press the button and slide it off.

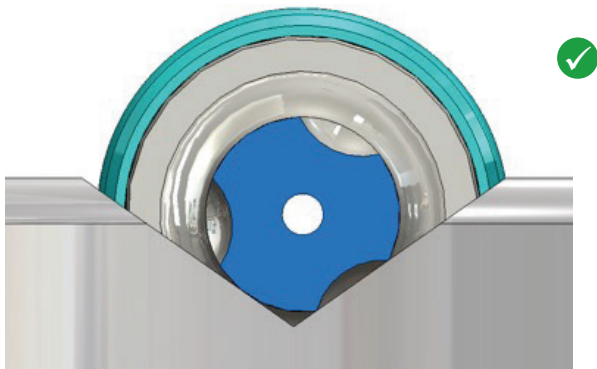
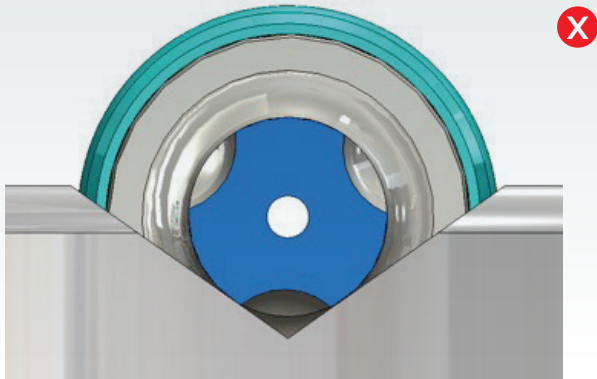

Figure 3



Figure 4

## Instrument Selection and Calibration

The surgeon must be thoroughly knowledgeable in the medical, surgical, mechanical, and software aspects of the Brainlab navigation systems and have reviewed all labeling including the instructions for use and the associated surgical techniques.

Consult the Brainlab user guide for information on selecting, calibrating, and verifying instruments. The following is additional guidance for calibrating the Vital System instruments with the Brainlab Array Kit.

Before using the system, Brainlab recommends that all users should participate in a training program held by a Brainlab representative to ensure safe and appropriate use.

**Note:** For instrument selections, select the generic instrument that correlates to the related Vital navigation instruments.

The software prompts you to choose from either a selected receptacle or the notch calibration technique. Calibrate all Vital System instruments using the notch technique.

## Guidance for Calibrating Taps

- Lay the tap in the notch in a stable position (Figure 3).
- Hold the tap in this position while rotating the array.

**Note:** Find a stable position *d* by laying the tap in the notch, then rotating it until you feel and hear the tap edges contact the ICM notch.

- During tip calibration, hold the Instrument Calibration Matrix and instrument orthogonally while rotating the array to avoid interferences from the thread (Figure 4).



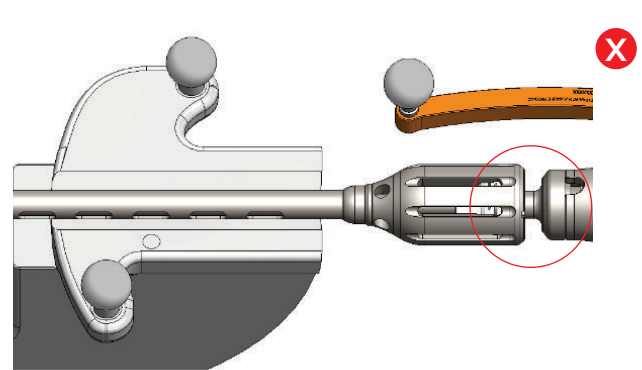
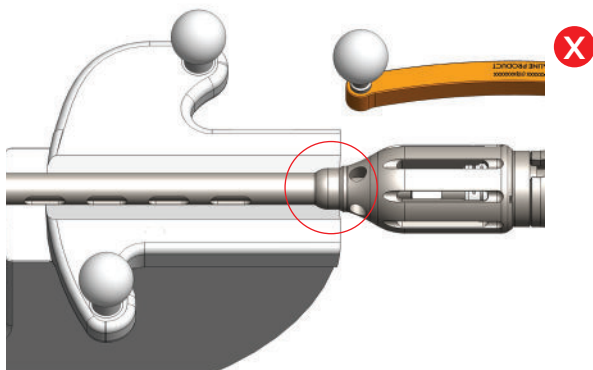
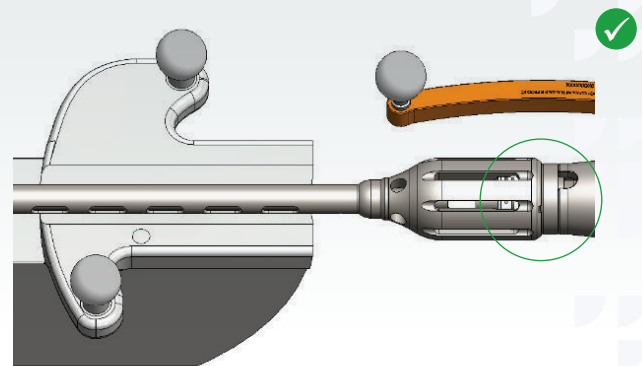
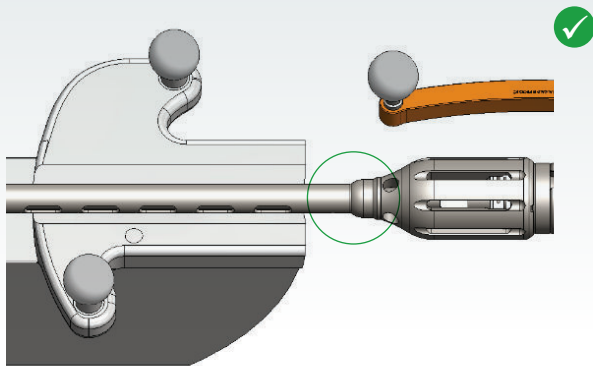

Figure 5

Figure 6

## Guidance for Calibrating Drivers

- Calibrate drivers without the plastic sleeve and screw attached for the notch calibration step.
- Lay the driver in the notch. Ensure that the Instrument Calibration Matrix (ICM) is in full contact with the smooth shaft of the driver (Figure 5).
- Ensure there is no movement between the outer sleeve and shaft by maintaining axial pressure on the driver in the notch while rotating the array (Figure 6).
- Before tip calibration, assemble the optional plastic sleeve and then assemble the selected screw to the appropriate driver.

**Note:** For Vital MIS Pedicle Screws the Vital Nav Reduction Driver should be used.

- Ensure that the driver tip is fully seated in the screw head, and the head capture system of the driver is fully tightened into the screw head.
  - All drivers feature a screw head capture system that must be fully engaged prior to the registration of the screw.
  - To properly operate the screw head capture system, the driver tip must fit into the screw head and the driver sleeve must be threaded into the screw head and tightened until the screw is rigidly fixed to the driver.
- During tip calibration, hold the Instrument Calibration Matrix and driver orthogonally in the pivot point, as shown above (Figure 4).



**Figure 7**

## Alternative Pedicle Prep Solution

The Vital Navigated Pedicle Access Tool (Nav PAT) can be used to combine the traditional steps of using a pedicle targeting needle to place a guidewire and tapping.

The Vital Nav PAT instrument combines a cortex-breaking stylus with the navigated tap so that direct tapping may occur.

- Before navigated tap selection and registration, assemble the Vital MIS PAT handle to the navigated tap. Slide the Vital Nav PAT stylus down through the Vital MIS PAT handle and thread the Vital Nav PAT stylus into the top of the navigated tap. There should be approximately 3.5 mm of protrusion (Figure 7).

**If using the PAT, calibrate the instrument with the stylus assembled.**

**Note:** When assembled to the Vital Navigated PAT, the protrusion of the stylus can vary by  $\pm 2.7$  mm.



**Figure 8**



**Figure 9**

## Alternative Screw Insertion Technique: PASIT Direct-to-Screw

The Vital Navigation Pedicle Access Screw Insertion Toll (Nav PASIT) Instrument combines a cortex-breaking stylus with the screwdriver so direct-to-screw insertion may occur with the Vital MIS or Vital Cannulated screws.

- After screw selection, assembly to driver and registration, select the appropriate size Vital Nav PASIT stylus (Figure 8) that corresponds to the length of the pedicle screw intended for insertion.
- Assemble the Vital MIS PAT handle to the navigated screwdriver. Slide the Vital Nav PASIT stylus down through the Vital MIS PAT handle and thread the Vital NAV PASIT stylus into the top of the Vital MIS PAT handle. Check that the tip of the Vital Nav PASIT stylus is protruding from the top of the pedicle screw. There should be approximately 3.5mm of protrusion (Figure 9). PAT and PASIT instruments both have a stylus of 3.5 mm from the tip of the instrument or implant.

**If using the PASIT, calibrate the driver and implant assembly without the stylus assembled.**

**Note:** Due to allowable manufacturing tolerances when assembled to the Vital Navigated PASIT, the protrusion of the stylus can vary by  $\pm 3.1$  mm.

## Navigation and Other Steps

---

For instruction on any additional features and usage of the Brainlab Navigation software, follow the procedures outlined in the Brainlab user guides.

For bone preparation, tapping, and screw insertion refer to the following surgical technique guides:

- Vital Spinal Fixation System Surgical Technique
- Vitality® Spinal Fixation System Surgical Technique

**Note:** *Throughout the procedure, display a pre-planned screw to visualize the trajectory.*

**Navigation Array Kit for Brainlab**  
**Kit Number: PCR131T0000**

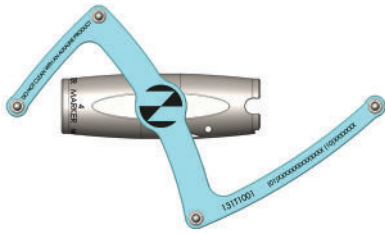
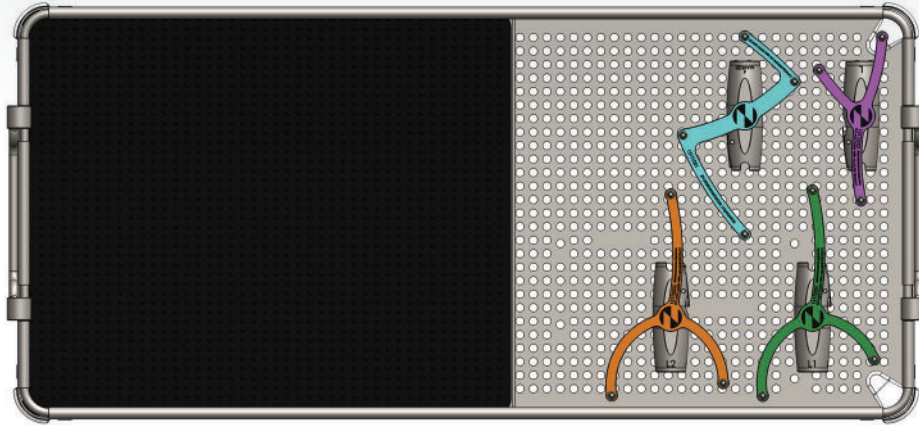

**4-Marker Reference Array**

PART NUMBER  
 131T1001



**L1 Reference Array**

PART NUMBER  
 131T2001



**L2 Reference Array**

PART NUMBER  
 131T2002



**L Reference Array**

PART NUMBER  
 131T2003

**Vital Navigation Instrument Kit**  
**Kit Number: PCR800M2000**

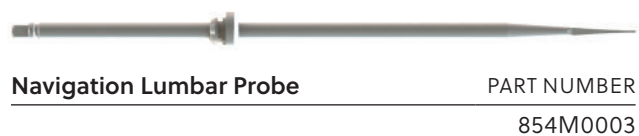
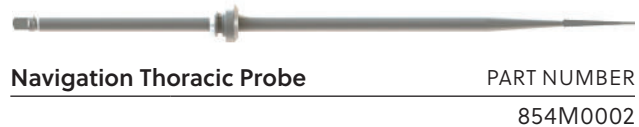
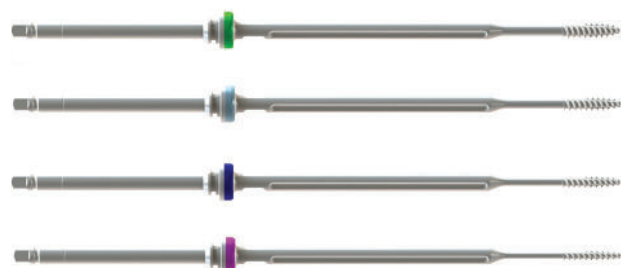
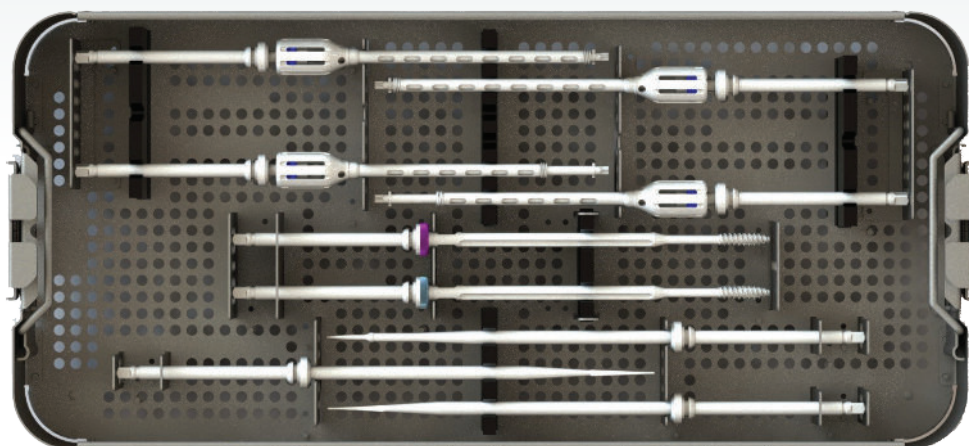

**Vital Nav PAT/PASIT Kit**  
**Kit Number: PCR800M1401**

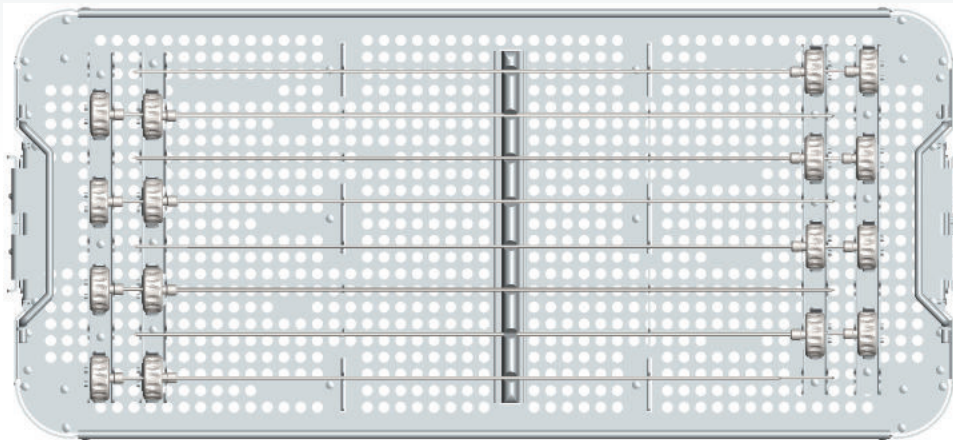

DESCRIPTION	QTY	PART NUMBER
PAT Tap Stylus	2	854M4000
PASIT Stylus - 30 mm	2	854M4030
PASIT Stylus - 35 mm	2	854M4035
PASIT Stylus - 40 mm	2	854M4040
PASIT Stylus - 45 mm	2	854M4045
PASIT Stylus - 50 mm	2	854M4050
PASIT Stylus - 55 mm	2	854M4055
PASIT Stylus - 60 mm	2	854M4060



PAT/PASIT Stylus	PART NUMBER
PAT Tap; 30 mm - 60 mm	854M4XXX

## Reference Array Compatibility Chart with Vital Navigation Instruments

INSTRUMENT TYPE	INSTRUMENT DESCRIPTION	PART NUMBER	COMPATIBLE TRACKING ARRAYS			
			L ARRAY	4-MARKER ARRAY	L1 ARRAY	L2 ARRAY
Awl	Vital Navigation Awl	854M0001	X	X	X	X
Probes	Navigation Lumbar Probe	854M0003	X	X	X	X
	Navigation Thoracic Probe	854M0002	X	X	X	X
Taps	Navigation Tap 4.5 mm	854M1045	X	X	X	X
	Navigation Tap 5.5 mm	854M1055	X	X	X	X
	Navigation Tap 6.5 mm	854M1065	X	X	X	X
	Navigation Tap 7.5 mm	854M1075	X	X	X	X
with/ without PAT Stylus	PAT Tap Stylus	854M4000	X	X	X	X
Drivers	Vital Navigation Driver	854M0021			X	X
	Vital Navigation Reduction Driver	854M0022			X	X
with/without PASIT Stylus	PASIT Stylus --30 mm	854M4030			X	X
	PASIT Stylus --35 mm	854M4035			X	X
	PASIT Stylus --40 mm	854M4040			X	X
	PASIT Stylus --45 mm	854M4045			X	X
	PASIT Stylus --50 mm	854M4050			X	X
	PASIT Stylus --55 mm	854M4055			X	X
	PASIT Stylus --60 mm	854M4060			X	X



## Important Information on the Vital Navigation System

Before using the Vital Navigation System non-sterile instruments, the operating surgeon should study carefully the following recommendations, warnings, and instructions; as well as the available product-specific information (e.g., product literature, written surgical technique). We are not liable for complications that may arise, from the use of the device, in circumstances outside of our control including, but not limited to, product selection, deviations from the device's intended uses, or surgical technique.

### PRODUCT COMPATIBILITY

The Vital Navigation System is intended to be used when placing Vital and Vitality screws using either the Medtronic StealthStation S7 or the Brainlab Spinal Navigation System. See the system labeling for the Vital System, Medtronic StealthStation S7, and Brainlab Spinal Navigation System for indications for use, intended use, and instructions for use of each system.

### INDICATIONS FOR USE

The Vital Navigation System instruments are used during the preparation and placement of the Vital and Vitality System screws during spinal surgery to precisely locate anatomical structures in either open or minimally invasive procedures. The Vital Navigation System instruments are designed for use with either the Medtronic StealthStation S7 or the Brainlab Spine & Trauma Navigation software. The ZimVie reference arrays can only be used with the Brainlab Spine & Trauma Navigation System.

### CONTRAINDICATIONS

The Vital Navigation System is not designed or sold for any use except as indicated. **DO NOT USE THE VITAL NAVIGATION SYSTEM INSTRUMENTS IN THE PRESENCE OF ANY CONTRAINDICATION.**

- Insufficient bone quantity, severe osteoporosis, or other condition that might compromise rigid fixation of the device.
- A history of infection, active systemic infection or infection localized to the site of the proposed implantation.
- Suspected or documented metal allergy or intolerance.
- A disorder affecting the normal process of bone remodeling, including but not limited to severe osteoporosis involving the spine, excessive bone reabsorption, osteopenia, a primary or metastatic tumor involving the spine, or certain metabolic disorders of osteogenesis.
- Iliac screws and offset connectors should not be used in cases of tumor or trauma of the sacrum, when additional screw fixation in S1 is not possible.
- Other relative contraindications include obesity, pregnancy, certain degenerative diseases, and foreign body sensitivity. In addition, the patient's occupation or activity level or mental capacity may be relative contraindications to this surgery. Specifically, some patients may, because of their occupation or lifestyle, or because of conditions such as mental illness, alcoholism or drug abuse, place undue stresses on the implant.
- The Vital Navigation System is contraindicated for any conditions listed for the Medtronic Navigation System and the compatible Vital and Vitality implant systems.
- The Vital Navigation system reference arrays are contraindicated for use with any instrumentation other than the Vital Navigation System instruments, and any navigation system other than the Brainlab Spinal Navigation System

### WARNINGS AND PRECAUTIONS

Following are specific warnings, precautions, and adverse effects associated with use of the Vital Navigation System that should be understood by the surgeon and explained to the patients. Surgeons should be thoroughly familiar with these instructions, in addition to all other product labeling. General surgical risk should be explained to the patients prior to surgery.

- Implantation of the Vitality System should be performed only by experienced spinal surgeons.
- All implants are intended for single use only. Single use devices should not be re-used. Possible risks associated with re-use of single-use devices include:
  - Mechanical malfunction
  - Transmission of infectious agents

- Metal sensitivity has been reported following exposure to orthopedic implants. The most common metallic sensitivities (nickel, cobalt, and chromium) are present in medical grade stainless steel and cobalt-chrome alloys.
- Universal precautions should be observed by all end users that work with contaminated or potentially contaminated medical devices. Caution should be exercised when handling devices with sharp points or cutting edges to prevent injuries during and after surgical procedures and reprocessing.
- ZimVie does not warrant Medtronic or Brainlab Navigation Software. It is the sole responsibility of the user to ensure instrument calibration and/or registration.
- The Use of the Vital Navigation System should only be used with the indicated Vital and Vitality screw systems.
- Users must complete verification steps as required per the Medtronic or Brainlab Navigation Technique.
- Users must ensure that surgical accuracy be assessed before the procedure and repeatedly throughout the procedure by positioning the tip of each navigated instrument on an identifiable anatomical landmark and comparing the actual tip location to that displayed by the system. When verifying the accuracy of the Navigated Drivers, the accuracy test must include the screw (of which diameter and length are selected/ entered into the software) assembled securely onto the driver. The screw tip will be placed on an identifiable anatomical landmark and compared to the tip location as displayed on the screen.
- In the event of a registration failure or suspected inaccuracy, the Navigated Instruments should not be used with the Navigation System and the instruments should be inspected for damage before continuing with the traditional, non-navigated procedure.
- The Vital Navigation System instruments should not be bent or altered in any way as this could lead to a reduction in system accuracy.
- **Warning:** The safety and effectiveness of pedicle screw spinal systems have been established only for spinal conditions with significant mechanical instability or deformity requiring fusion with instrumentation. These conditions are significant mechanical instability or deformity of the thoracic, lumbar, and sacral spine secondary to severe spondylolisthesis (grades 3 and 4) of the L5 S1 vertebra, degenerative spondylolisthesis with objective evidence of neurological impairment, fracture, dislocation, scoliosis, kyphosis, spinal tumor, and failed previous fusion (pseudoarthrosis). The safety and effectiveness of these devices for any other conditions are unknown.
- **Warning:** The safety and effectiveness of this device has not been established for use as part of a growing rod construct. The device is only intended to be used when definitive fusion is being performed at all instrumented levels.

#### Additional Warnings for Pediatric Patients:

- The use of pedicle screw fixation in the pediatric population may present additional risks when patients are of smaller stature and skeletally immature. Pediatric patients may have smaller spinal structures (pedicle diameter or length) that may preclude the use of pedicle screws or increase the risk of pedicle screw malpositioning and neurological or vascular injury. Patients who are not skeletally mature undergoing spinal fusion procedures may have reduced longitudinal spinal growth, or may be at risk for rotational spinal deformities (the “crankshaft phenomenon”) due to continued differential growth of the anterior spine.
- **Precaution:** The implantation of pedicle screw spinal systems should be performed only by experienced spinal surgeons with specific training in the use of this pedicle screw spinal system because this is a technically demanding procedure presenting a risk of serious injury to the patient.

### Additional Precautions for Pediatric Patients:

- The implantation of pedicle screw spinal systems in pediatric patients should be performed only by experienced spinal surgeons with specific training in the use of this pedicle screw spinal system in pediatric patients because this is a technically demanding procedure presenting a risk of serious injury to the patient.
- Preoperative and operating procedures, including knowledge of surgical techniques, good reduction, and proper selection and placement of the implants are important considerations in the successful utilization of the system in pediatric patients.
- The selection of the proper size, shape and design of the implant for each patient is crucial to the safe use of this device in pediatric patients.

### PREOPERATIVE

- Usage of automated cleaning processes without supplemental manual cleaning may not result in adequate cleaning of instruments.
- Proper handling, decontamination (including pre-rinsing, washing, rinsing and sterilization), storage and utilization are important for the long and useful life of all surgical instruments. Even with correct use, care and maintenance, they should not be expected to last indefinitely. This is especially true for cutting instruments (e.g., bone awls/drills) and driving instruments (e.g., drivers). These items are often subjected to high loads and/or impact forces. Under such conditions, breakage can occur, particularly when the item is corroded, damaged, nicked or scratched.
- Never use titanium, titanium alloy, and/or cobalt chromium with stainless steel in the same implant construct; otherwise, galvanic corrosion may occur.
- ZimVie does not specify the maximum number of times a re-usable instrument may be re-used. The useful life of these instruments is highly dependent on a number of factors including the frequency and manner in which they are used and the handling they experience in between uses.

### INTRAOPERATIVE

- If contouring of the implant is necessary for optimal fit, the contouring should be gradual and avoid any notching or scratching of the implant surface. Do not repeatedly or excessively bend the implant. Do not reverse bend the rods.
- Pedicle bone integrity should be verified.
- Care should be taken during pedicle preparation to avoid penetrating too deep.
- Care should be taken during bone preparation to avoid damage to the pedicle and to the surgical instruments.
- Care should be taken to minimize soft tissue damage during surgery.
- Care should be taken to avoid removing excess material from the lamina.
- Care should be taken to avoid cross-threading screws and closure tops.
- If any implant or instrument comes in contact with a non-sterile surface it should not be used.

### POSTOPERATIVE

- Adequately instruct the patient. Postoperative care and the patient's ability and willingness to follow instructions are one of the most important aspects of successful bone healing. The patient must be made aware of the limitations of the implant and that physical activity and full weight bearing have been implicated in fracture. The patient should understand that an implant is not as strong as normal, healthy bone and will fracture if excessive demands are placed on it in the absence of complete bone healing. An active, debilitated, or demented patient who cannot properly use weight-supporting devices may be particularly at risk during postoperative rehabilitation.
- The Vitality System is a temporary internal fixation device. Internal fixation devices are designed to stabilize the operative site during the normal healing process. After healing occurs, these devices serve no functional purpose and should be removed. Implant removal should be followed by adequate postoperative management to avoid fracture or refracture.

## ADVERSE EFFECTS

Complications and adverse reactions have been reported with the use of similar spinal instrumentation systems. These adverse effects, including the possibility of death, should be discussed with the patient prior to surgery.

- Non-union, delayed union
- Bending or fracture of implant. Fraying, kinking, loosening, bending or breaking of any or all implant components
- Loosening of or migration of the implant
- Metal sensitivity or allergic reaction to a foreign body
- Infection
- Decrease in bone density due to stress shielding
- Pain, discomfort, or abnormal sensations due to the presence of the device
- Loss of the natural curvature of the spine
- Modification of the spinal geometric corrections of the vertebral and/or intervertebral height and/or of the reduction in spinal deformities
- Vascular and/or nerve damage due to surgical trauma or presence of the device.
- Neurological difficulties including bowel and/or bladder dysfunction, impotence, retrograde ejaculation and paraesthesia.
- Bursitis
- Dural leak
- Paralysis
- Death
- Erosion of blood vessels due to the proximity of the device, leading to hemorrhage and/or death
- Additional surgery may be required to correct any of these potential adverse effects

## Additional Potential Adverse Effects for Pediatric Patients:

1. Inability to use pedicle screw fixation due to anatomic limitations (pedicle dimensions, distorted anatomy)
2. Pedicle screw malpositioning, with or without neurological or vascular injury
3. Proximal or distal junctional kyphosis
4. Pancreatitis

Other adverse events related to pedicle screw fixation, such as screw or rod bending, breakage, or loosening, may also occur in pediatric patients, and pediatric patients may be at increased risk for device-related injury because of their smaller stature.

For more information, visit [ZimVie.com](http://ZimVie.com)



Zimmer Biomet Spine, Inc.  
10225 Westmoor Dr.  
Westminster, CO 80021 USA  
[ZimVie.com](http://ZimVie.com)



**Disclaimer:** This document is intended exclusively for physicians and is not intended for laypersons. Distribution to any other recipient is prohibited. Information on the products and procedures contained in this document is of a general nature and does not represent and does not constitute medical advice or recommendations. Because this information does not purport to constitute any diagnostic or therapeutic statement with regard to any individual medical case, each patient must be examined and advised individually, and this document does not replace the need for such examination and/or advice in whole or in part.

**Caution:** Federal (USA) law restricts this device to sale by or on the order of a physician. Rx only. Please refer to the package inserts for important product information, including, but not limited to, indications, contraindications, warnings, precautions, adverse effects, and patient counseling information.

**eLabeling:** The Instructions for Use can be accessed online by visiting the website shown below. Additional languages are also available in electronic format for download. To request a paper copy of the Instructions for Use, contact ZimVie Spine at the phone number provided.

Consult Instructions for Use on this website <http://labeling.zimvie.com>

Unless otherwise indicated, as referenced herein, all trademarks and intellectual property rights are the property of ZimVie Inc. or an affiliate; and all products are manufactured by one or more of the spinal subsidiaries of ZimVie Inc. (Zimmer Biomet Spine, Inc., Zimmer Spine, LDR Medical, etc.) and marketed and distributed by Zimmer Biomet Spine and its authorized marketing partners. Medtronic StealthStation, Medtronic Synergy Experience and Medtronic are trademarks of Medtronic PLC. Vital Navigation System is manufactured by Zimmer Biomet Spine. For additional product information, please refer to the individual product labeling or instructions for use. Products within this system are under the design control of various legal manufacturers. Refer to the product labeling of each device for the legal manufacturer. Product clearance and availability may be limited to certain countries/regions. This material is intended for clinicians only and does not comprise medical advice or recommendations. Distribution to any other recipient is prohibited. This material may not be copied or reprinted without the express written consent of ZimVie. ZVINST0180.1-US-EN-2023.12 ©2023 ZimVie Inc. All rights reserved.

**R<sub>x</sub> only**