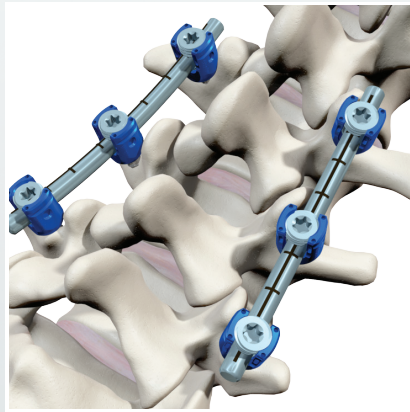
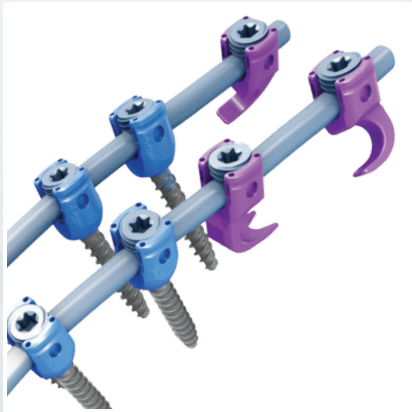




# Vital™ Deformity

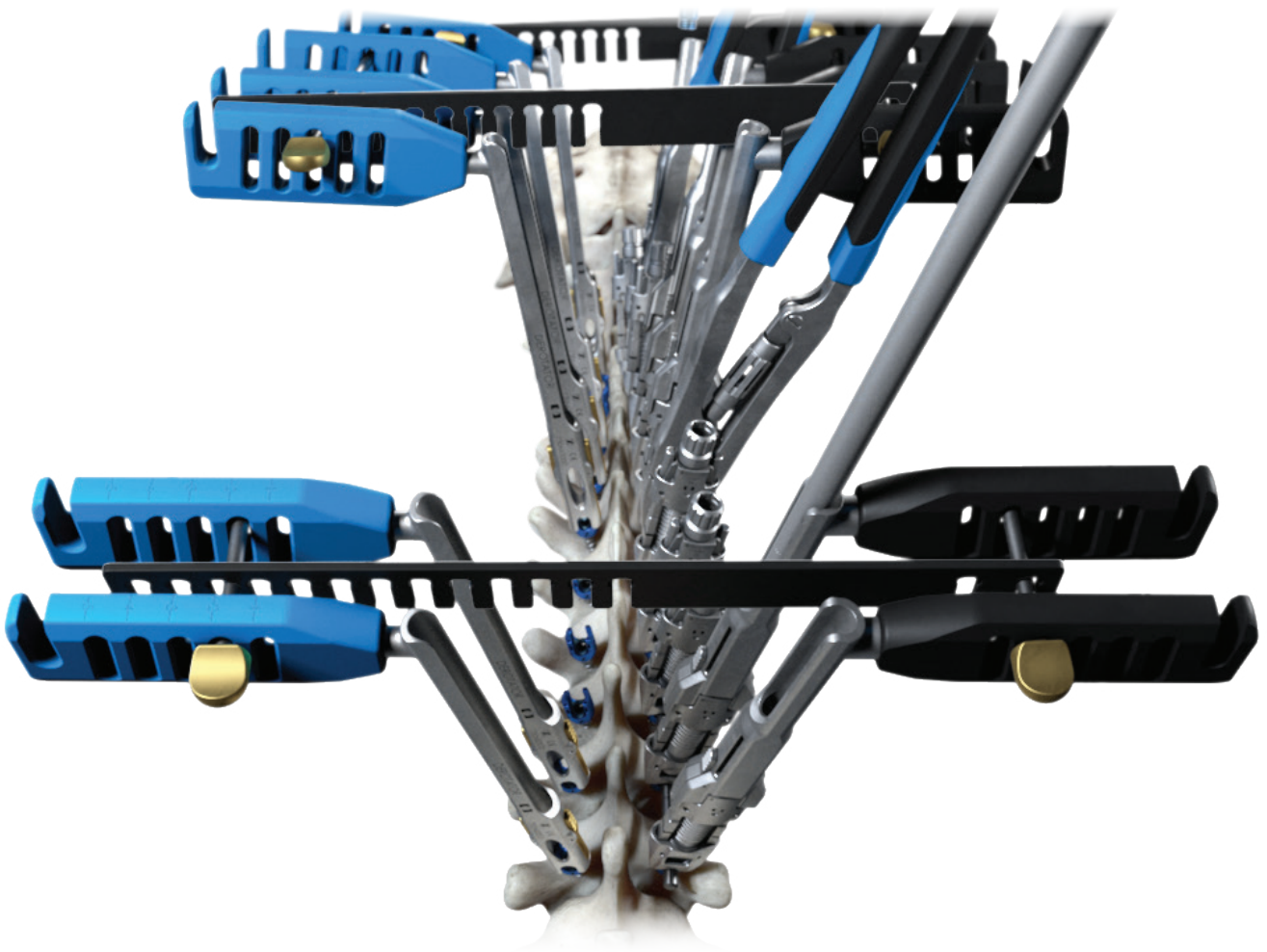
Spinal Fixation System

Surgical Technique Guide



# Vital™ Deformity Spinal Fixation System

The Vital Spinal Fixation System was developed to address the modern demands of surgeons treating complex spinal pathologies. The system provides a comprehensive solution for rigid spinal fixation, from the thoracic spine to the ilium.



## Table of Contents

Vital Spinal Fixation System Overview	4
Vital Implant Features and Screw Specifications	6
Surgical Technique	
Pedicule Screw Placement	8
Manual Pedicle Preparation and Screw Insertion	10
Pedicule Screw Insertion	14
Assembly/Disassembly of ZimVie Universal Power System and Vital Power	15
Powered Pedicle Preparation and Screw Insertion	18
Vital Hooks Overview	23
Surgical Techniques using Hooks	26
Optional Iliac Fixation	31
Rod Insertion and Provisional Tightening	35
Reduction Instrumentation	39
Compression and Distraction	50
Final Tightening	52
Connector Options	55
Final Construct	58
Removal or Revision	59
Vital Deformity Derotation and Instrumentation	60
Kit Ordering Overview	69
Kit Contents	73
Quick Reference Guide to Implant Caddies	102
Implant Visual Guide	103
Instruments	106
Optional Instruments	115
Important Information on the Vitality Spinal Fixation System	119

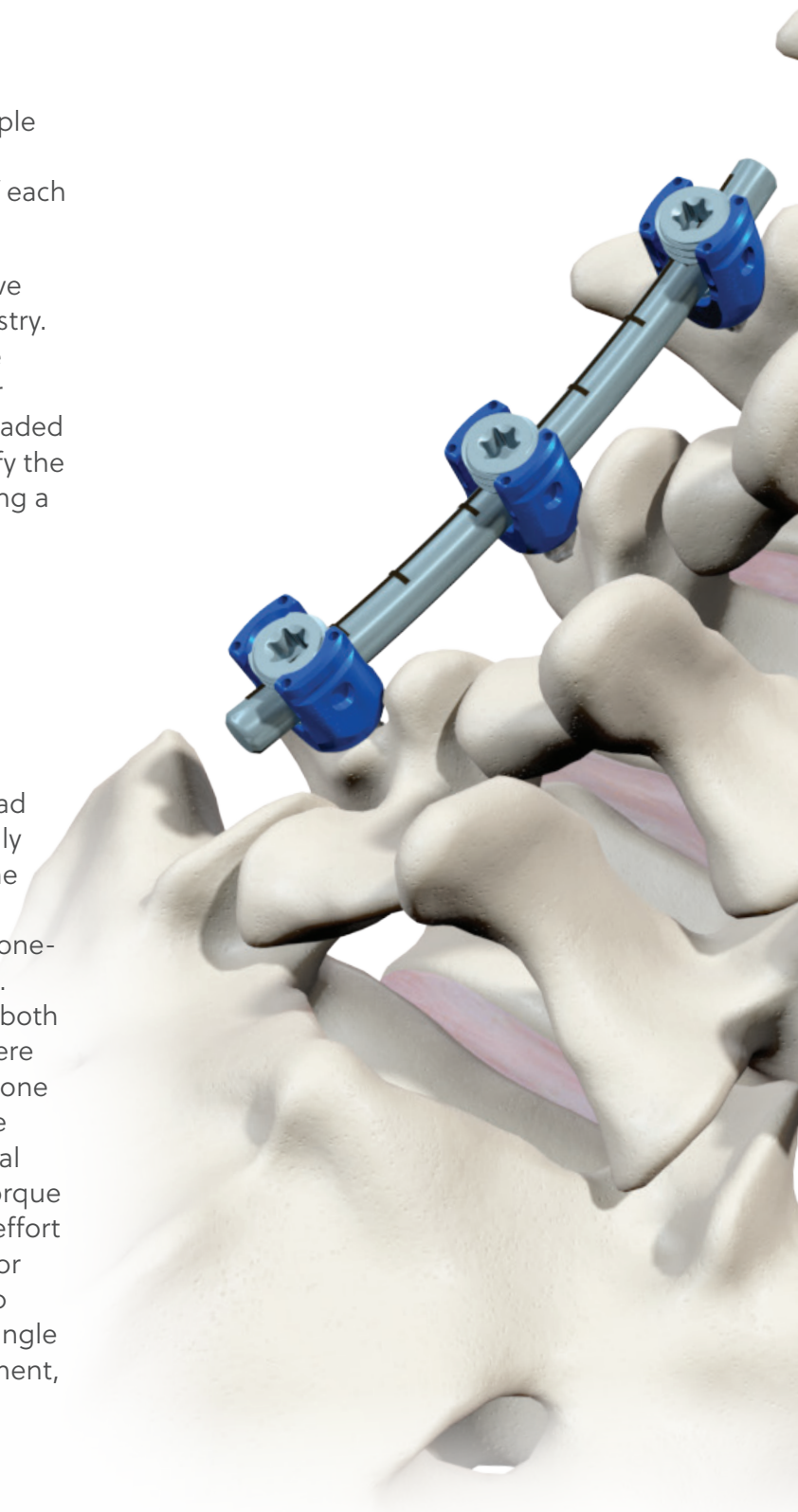
ZimVie Spine does not practice medicine. This technique was developed in conjunction with health care professionals. This document is intended for surgeons and is not intended for laypersons. Each surgeon should exercise his or her own independent judgment in the diagnosis and treatment of an individual patient, and this information does not purport to replace the comprehensive training surgeons have received. As with all surgical procedures, the technique used in each case will depend on the surgeon's medical judgment as the best treatment for each patient. Results will vary based on health, weight, activity and other variables. Not all patients are candidates for this product and/or procedure.

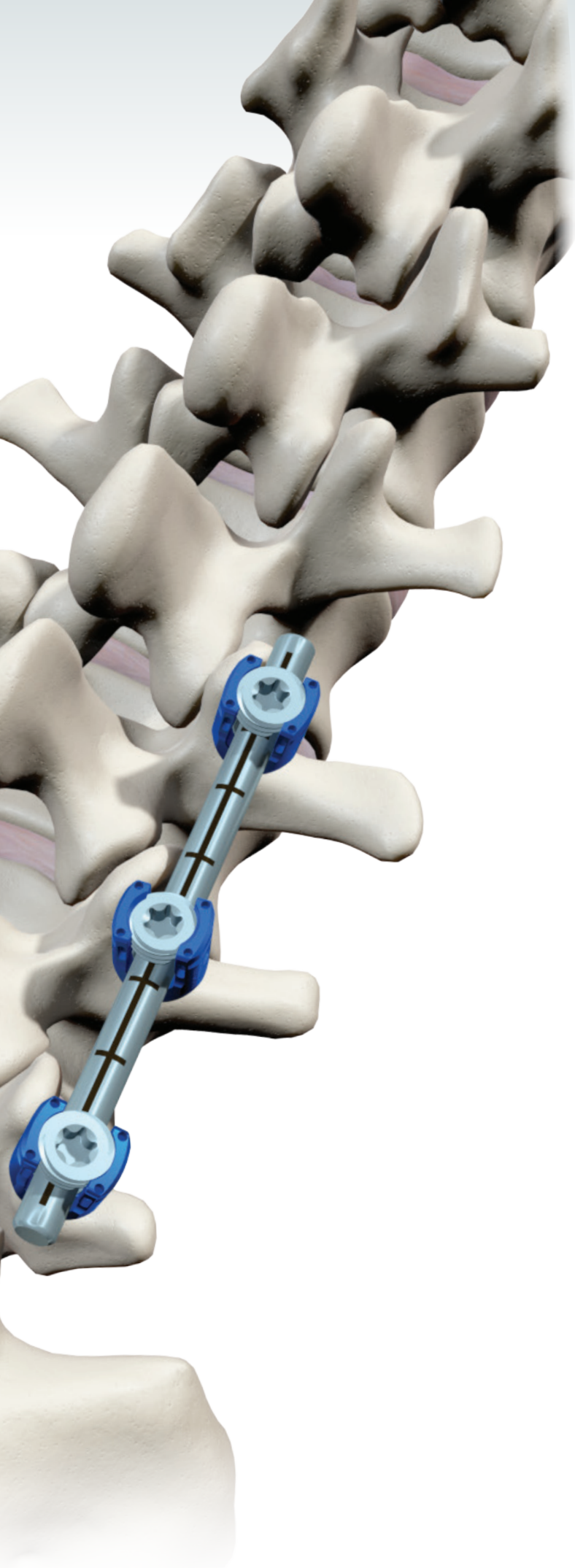
## Vital Spinal Fixation System Overview

The Vital System includes multiple screw options: monoaxial, polyaxial, uniplanar, reduction and iliac. All screw types are available in multiple diameters and lengths. In order to provide the surgeon with greater intraoperative flexibility, the fixation implants are specifically designed to accept both 5.5 and 6.0 mm diameter rods, in either Titanium, or Cobalt Chromium. The ability to intraoperatively pivot between multiple rod options with the same system, allows the surgeon to better accommodate the needs of each individual patient.

All Vital screws incorporate a T27 hexalobe drive feature which is one of the largest in the industry. The T27 drive feature is 30% stronger than the T25 hexalobe and is designed to reduce driver breakage. All Vital screws incorporate an upgraded attachment feature that is designed to simplify the engagement of multiple instruments, providing a solid connection for manipulation.

All polyaxial and uniplanar screws feature a proprietary friction fit head, designed to hold the desired head position and facilitate rod placement. All the pedicle screws feature a dual-lead thread form that doubles insertion speed, without sacrificing pull-out strength, when evaluated against comparable single lead screw thread forms. The screws also offer a fully threaded screw shank designed to improve the starting characteristics of the screw. The Vital System screw shank is designed to improve bone-screw fixation while reducing insertion torque. The thread material profile, thread pitch, and both the major and minor diameter of the screw were upgraded, so as to maximize the amount of bone material compacted between the threads. The Vital System's iliac screws offer a low pitch, dual lead thread designed to minimize insertion torque and require fewer revolutions to insert, in an effort to reduce surgeon fatigue and the potential for driver breakage. The Vital System's closure top incorporates a blunt start, dual lead, reverse angle thread designed to improve starting engagement, advance quickly and help prevent head splay.





The Vital System also offers a variety of implant options including multiple rod to rod connectors, lateral offset connectors (iliac), fixed and adjustable transverse connectors, 5.5 and 6.0 mm pre-cut, curved and straight titanium and cobalt chromium rods. The Vital System deformity rods include reference markings every 1 cm along the rod and a large hex end feature for de-rotation maneuvers.

The Vital System instrumentation is designed to treat a wide variety of spinal pathologies and to allow surgeons the flexibility to build constructs that meet the anatomical challenges associated with complex spine procedures. The Vital System instrumentation is designed for ergonomic comfort and surgical efficiency. The offering of reduction and manipulation instruments supports complex spinal surgery with ease of use and expediency of implantation at their core.

The Vital Spinal Fixation System incorporates innovative instrumentation for posterior three-dimensional spinal deformity correction techniques. These techniques give the surgeon the ability to correct most spinal deformities in all three dimensions. With idiopathic scoliosis in adolescents, it has been shown that lumbar motion segments can be spared in thoracolumbar and lumbar curves, truncal offset can be more predictably reduced, and significant rib hump correction can be achieved without the need for thoracoplasty. Force coupling is an integral part of the correction process. Multiple screws clustered about the curve apex can be linked and levered synchronously to achieve axial plane correction. In designing this system, special attention was given to maximizing ease of use, by following a stepwise, non-regressive technique, for the purpose of optimizing efficiency.

# Vital Implant Features

## Multiple Instrument Connection Features

- The multiple screw head connection points allow various instruments to quickly and securely attach, simplifying manipulation maneuvers.

## Friction Fit Screw Head

- Retains alignment, allowing for easy screw-rod orientation and ease of screw loading.
- Accommodates  $\varnothing 5.5$  mm and  $\varnothing 6.0$  mm rods.

## Fully Threaded Dual-lead Screw Shank

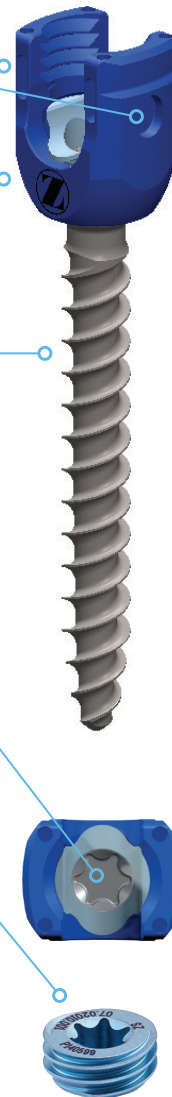
- Self-tapping fully threaded blunt tip screw shank designed to improve the starting characteristics and improve bone screw fixation while reducing insertion torque.
- Improves surgeon efficiency by allowing screw insertion twice as fast as comparable single lead screws without sacrificing pull-out strength.\*

## T27 Hexalobe Drive Feature

- Screws and closure tops utilize T27 drive (one of largest in industry): 30% greater strength than T25 drive (MDT), 90% greater strength than T20 drive (D/S).\*

## Dual-lead Reverse Angle Thread Closure Top

- Dual-lead reverse angle thread designed to improve engagement, advance quickly and help prevent head splay.
- Closure top design supports loosening after final tightening and re-tightening of closure top without performance loss.



## Screw Sizes

- The Vital Deformity System includes multiple screw options; monoaxial, polyaxial, uniplanar, reduction and iliac.
- All screw types are available in multiple diameters and lengths designed to secure to either 5.5 or 6 mm rods in titanium or cobalt chromium — which provide different strength and stiffness options.

Color	Diameter
Gold	4.0 mm
Magenta	4.5 mm
Dark Blue	5.5 mm
Light Blue	6.5 mm
Green	7.5 mm
Gold	8.5 mm
Light Blue	9.5 mm
Purple	10.5 mm

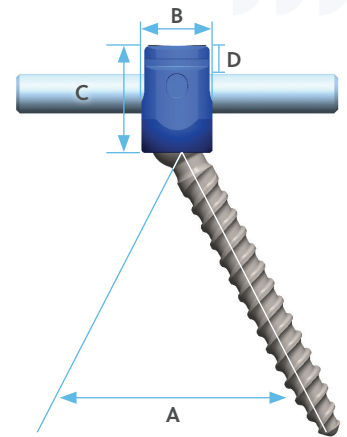
\*Data on file.

## Polyaxial Screw Specifications

Thread Major Diameter	(A) Cone of Angulation	(B) Run on Rod	(C) Head Height	(D) Height Above 5.5 mm Rod	Neck Diameter
4.0 mm	67°	9.1 mm	15 mm	3.94 mm	4.01 mm
4.5 mm	58°	9.1 mm	15 mm	3.94 mm	4.52 mm
5.5 mm	54°	9.1 mm	15 mm	3.94 mm	4.77 mm
6.5 mm	54°	9.1 mm	15 mm	3.94 mm	4.77 mm
7.5 mm	54°	9.1 mm	15 mm	3.94 mm	4.77 mm
8.5 mm	44°	9.1 mm	16.5 mm	3.94 mm	4.77 mm
9.5 mm	35°	9.1 mm	16.5 mm	3.94 mm	5.26 mm
10.5 mm	35°	9.1 mm	16.5 mm	3.94 mm	5.26 mm

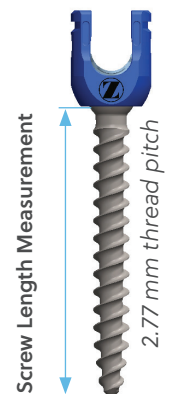
## Uniplanar Screw Specifications

Thread Major Diameter	(A) Cephalad/Caudal Angulation	(B) Run on Rod	(C) Head Height	(D) Height Above 5.5 mm Rod	Neck Diameter
4.5 mm	58°	9.1 mm	15 mm	3.94 mm	4.52 mm
5.5 mm	54°	9.1 mm	15 mm	3.94 mm	4.77 mm
6.5 mm	54°	9.1 mm	15 mm	3.94 mm	4.77 mm
7.5 mm	54°	9.1 mm	15 mm	3.94 mm	4.77 mm



## Monoplanar Screw Specifications

Thread Major Diameter	(A) Cephalad/Caudal Angulation	(B) Run on Rod	(C) Head Height	(D) Height Above 5.5 mm Rod	Neck Diameter
4.0 mm	N/A	9.1 mm	15 mm	3.94 mm	4.52 mm
4.5 mm	N/A	9.1 mm	15 mm	3.94 mm	4.77 mm
5.5 mm	N/A	9.1 mm	15 mm	3.94 mm	4.77 mm
6.5 mm	N/A	9.1 mm	15 mm	3.94 mm	4.77 mm
7.5 mm	N/A	9.1 mm	15 mm	3.94 mm	4.77 mm

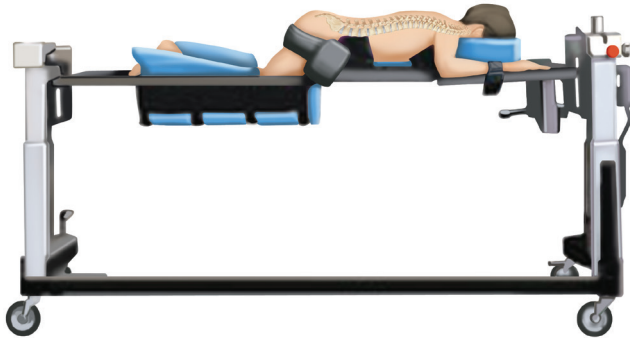


## Iliac Screw Specifications

Thread Major Diameter	(A) Cephalad/Caudal Angulation	(B) Run on Rod	(C) Head Height	(D) Height Above 5.5 mm Rod	Neck Diameter
7.5 mm	35°	9.1 mm	16.5 mm	3.94 mm	5.25 mm
8.5 mm	35°	9.1 mm	16.5 mm	3.94 mm	5.25 mm
9.5 mm	35°	9.1 mm	16.5 mm	3.94 mm	5.25 mm
10.5 mm	35°	9.1 mm	16.5 mm	3.94 mm	5.25 mm

## Surgical Technique

The following surgical technique guide describes the recommended placement and use of all Vital Spinal Fixation System components.

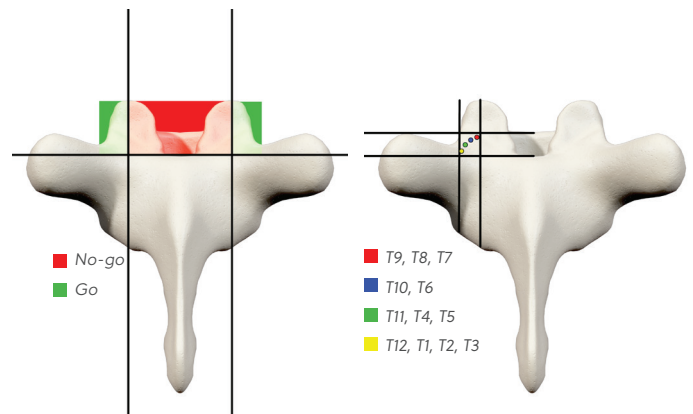


**Figure 1**  
Patient positioning

### Patient Positioning

- Place patient in the prone, or knee-chest, position on a radiolucent operating table (Figure 1). Take care to ensure that the patient's abdomen remains unsuspected. By allowing the patient's lumbar region to hang freely, the surgeon can maximize the patient's naturally occurring lordosis and minimize epidural bleeding. Adjust the table (as needed) so that the C-arm provides true A/P images when at 90° and true lateral images at 0°.

## Pedicle Screw Placement



**Figure 2**  
Thoracic pedicle trajectory targeting chart

### Thoracic Pedicle Targeting

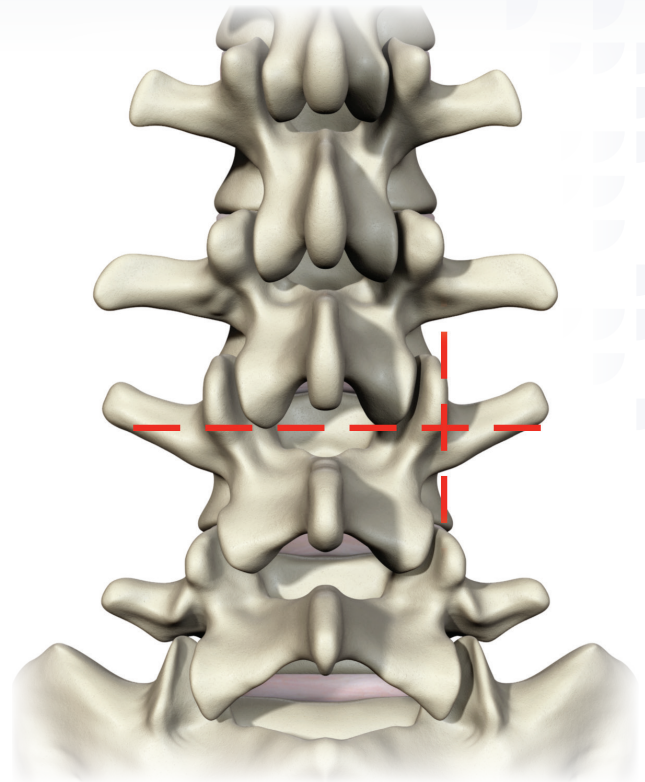
- Precise positioning of the pedicle entry point is essential. Using standard anatomic markings, resect a small portion of the dorsal cortex to create an entry point (Figure 2). Proper orientation of the pedicle screw is dependent upon the position of the pilot hole.





**Figure 3**  
*Hemifacetectomy*

- For thoracic pedicle screws, a hemifacetectomy of the inferior articular process at the level above the targeted pedicle is necessary. As an example, when targeting a T6 pedicle, the inferior articular process of T5 must be resected, in order to gain proper access to the pedicle. These hemifacetectomies also allow greater range of motion at each segment when performing deformity correction (Figure 3).



**Figure 4**  
*Lumbar pedicle targeting*

### Lumbar Pedicle Targeting

- For lumbar pedicle screws, the pilot hole should be started where a line through the middle of the transverse process crosses a vertical line at the lateral edge of the facet joints (Figure 4).

## Manual Pedicle Preparation and Screw Insertion



**Figure 5**  
Manual pedicle preparation - probing



**Figure 6**  
Manual pedicle preparation - curved Lenke probe

### Awl

- Using the awl, pierce the bone cortex at the entry point (Figure 5).  
**Note:** The optional thoracic bone awl creates a 2.75 mm wide by 8 mm deep pilot hole and the standard lumbar bone awl creates a 4 mm wide by 10 mm deep pilot hole.
- Using one of the Lenke pedicle probes provided in the Vital system, place the instrument's tip into the entry point created by the awl. Keeping proper pedicle trajectory in mind, pass the probe's tip down the pedicle's medullary channel.

### Probe

- If using the curved Lenke probe, make sure the curved tip initially faces laterally, as it is passed through the pedicle's medullary channel.
- Once the tip of the instrument has reached the border between the pedicle and the vertebral body, remove the instrument from the pedicle and re-insert with the pedicle probe's curved tip facing medially.
- Continue progressing the pedicle probe forward until the desired depth has been reached. Using the curved Lenke probe, make sure the curved tip is initially pointed laterally for the first 20-25 mm (to avoid breaching the medial cortex) (Figure 6).

**Note:** Laser markings are etched onto the probe tip every 10mm to assist with determining the depth of the probe.

**Note:** There are different pedicle probes provided in the Vital System, in order to accommodate individual surgeon preference and patient anatomy. These may be used in place of the curved Lenke probe, at the discretion of the surgeon.



**Figure 7**  
Manual pedicle preparation – sounding



**Figure 8**  
Manual pedicle preparation - tapping

## Confirm Pedicle Integrity

- After removing the pedicle probe, verify the integrity of the pedicle and the vertebral body walls using the ball tip probe (Figure 7). When fully inserted, forceps can be clamped onto the ball-tip probe to determine the hole depth for choosing the appropriate screw length.

**Note:** 10 mm laser markings are etched on the distal portions of each probe to assist with determining the depth of the probe when it is fully inserted into the bone. Optional pedicle markers for fluoroscopic visualization, are available upon request. See the optional instruments section of this guide, starting on page 115.

## Tapping

- Connect the appropriate diameter tap to the desired handle. Insert the tap into the pedicle and rotate it clockwise. A depth gauge on the tap indicates the hole depth. Remove the tap by turning the dial on the handle to the reverse position and then rotating the handle itself in a counterclockwise motion (Figure 8).

**Note:** The Vital System offers taps that are true to labeled size. After removing the tap, the ball-tip probe can be used again to verify the integrity of the pedicle and vertebral body walls.

**Note:** Guidewires and cannulated taps may be used in conjunction with each other, if desired. Cannulated polyaxial, uniplanar, and monoaxial screws are available, should the surgeon choose to use these implants. Additional information regarding guidewire insertion and use with cannulated instruments and implants can be found in the Vital MIS Surgical Technique Guide as needed.

## Manual Pedicle Preparation and Screw Insertion (continued)



**Figure 9**  
Manual pedicle screw insertion – loading polyaxial, uniplanar, monoplanar, and iliac screws

### Selecting Appropriate Pedicle Screw

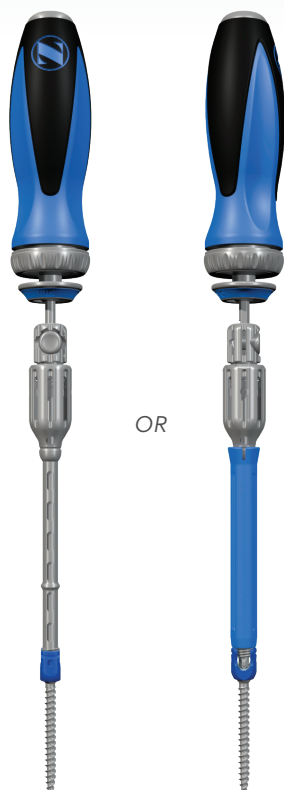
- Depending on the spinal pathology being treated, a surgeon may choose to utilize different types of pedicle screws. Polyaxial screws are generally the most commonly utilized screw.
- Uniplanar screws will most often be utilized at the apex of a scoliotic curve, because they are fixed in the medial-lateral plane. Uniplanar screws are designed to provide additional stability during vertebral body derotation maneuvers, to help restore global balance.
- Monoaxial screws can also be utilized at the apex of a scoliotic curve, as they are also intended to provide additional stability during vertebral body derotation maneuvers.

**Note:** It is recommended that reduction instrumentation be used, when placing monoaxial screws at the end of a construct. This will ensure the rod is fully seated in the screw head prior to introducing and final tightening the closure top.

### Standard Screwdriver Loading

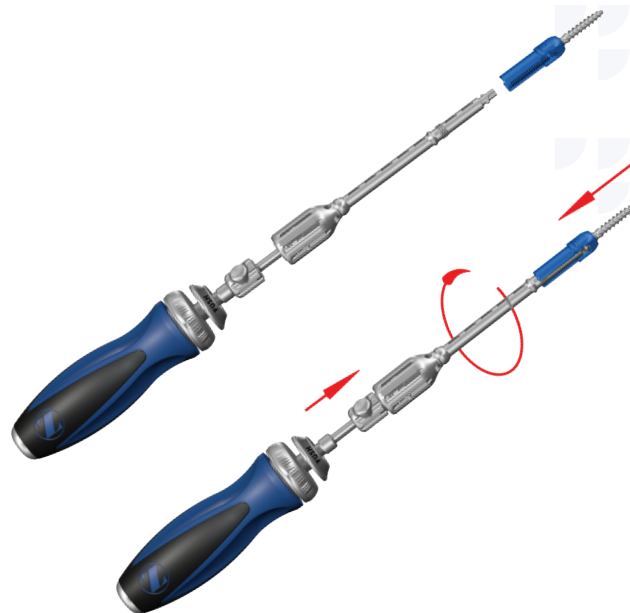
Depending on the spinal pathology being treated, a surgeon may choose to utilize different types of pedicle screws.

- 1 Connect the ratcheting straight handle to the standard screwdriver.
- 2 Place the appropriate screw on to the standard screwdriver by inserting the screwdriver tip into the female hexalobe on the screw shank, making sure the screw shank is straight.
- 3 Secure the screw by turning the standard screwdriver sleeve clockwise into the screw head.
- 4 The screwdriver sleeve may be locked by pushing the button on the secondary lock and sliding the collar downwards. This secure locking system is designed to prevent screw loosening and toggle during insertion. Confirm the collar is fully engaged and locked.



**Figure 10**  
Screwdriver tissue sleeve

**Note:** The screwdriver tissue sleeve may be used during this step. To connect, slide the tissue sleeve over the screwdriver sleeve until it is fully engaged on the retaining feature. The tissue sleeve must be assembled prior to loading the pedicle screw (Figure 10).



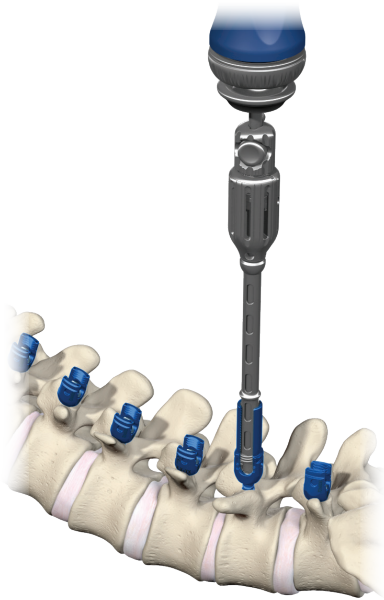
**Figure 11**  
Manual pedicle screw insertion – loading reduction polyaxial and uniplanar screws

## Screw Driver Assembly — Reduction Screws

For reduction screws, connect the reduction screw driver to the desired handle.

- Place the appropriate length screw on the reduction screw driver by inserting the screw driver tip into the female hexalobe on the screw shank.
- Secure the reduction screw by turning the screw driver retention sleeve clockwise. The screw driver sleeve may be locked by pushing the button on the secondary lock and sliding the collar forward. This secure locking system prevents screw loosening and toggle during insertion (Figure 11).
- Confirm the collar sleeve is fully engaged and locked.

## Pedicle Screw Insertion



**Figure 12**  
Manual pedicle screw placement – screw insertion



**Figure 13**  
Manual pedicle screw placement – removing screwdriver

### Screw Insertion

- Insert the screw through the prepared pedicle until it reaches the desired depth (Figure 12).

### Release Screwdriver

- To release standard, short, or reduction screwdrivers, first depress the button on the screwdriver lock, then retract the lock towards the handle. Finally, turn the sleeve counterclockwise, until no longer threaded into the head of the screw (Figure 13).
- Repeat pedicle preparation and screw insertion steps for all of the screws.

## Assembly/Disassembly of ZimVie Universal Power System and Vital Power



**Figure 14**  
Universal Power components needed to use Vital Power

### Universal Power System Handpiece & Attachment Assembly

The Vital Power Instrument Kit features five types of instruments that are available for use with the Zimmer Biomet Universal Power System: drills, reamers, taps, drivers, and adapters. The Universal Power System is available in 2 handpiece styles: the single trigger handpiece and the double trigger handpiece (Figure 14). The Universal Power System also features various attachments that alter the speed and torque of the handpiece. Please refer to the ZimVie Universal Power System Instruction Manual (06001800100) for in-depth information on the system.

**Note:** The ZimVie Universal Power System is not manufactured or sold by ZimVie Spine. Please contact ZimVie Surgical Solutions group to acquire these handpieces.



**Figure 15**  
Virage small AO fixed handle

### Vital Power Drill/Reamer & Universal Power Small AO Attachment Assembly

The drills and reamers are intended for use with the Universal Power 1000 RPM Small AO Attachment. To assemble, insert the Universal Power Small AO Attachment into the Universal Power Handpiece of choice, ensuring the teeth of the attachment align with those of the handpiece. Once assembled, pull back the top sleeve of the attachment, to insert a drill or reamer. Following insertion, drills and reamers should be checked, so as to ensure proper mating with the Universal Power Small AO attachment (Figure 15).

**Note:** When using the double trigger handpiece, press the bottom trigger for clockwise rotation. For counterclockwise rotation, first press the top trigger, followed by the bottom trigger.

**Note:** The toggle switch located above the trigger determines the direction of rotation, for the single trigger handpiece.

**Note:** If needed, the Vitality+ Power Instrument Kit includes a straight, non-ratcheting handle that accepts Vital Power instruments that feature a male, Small AO connection.

## Assembly/Disassembly of ZimVie Universal Power System and Vital Power (continued)

Short threaded (non-locking) T27 driver



Stab-n-grab T27 driver



Standard threaded (non-locking) T27 driver



250 rpm Zimmer/Hudson attachment



Double trigger handpiece



Compact battery charger – accepts sterilizable and aseptic batteries



Sterilizable battery



Aseptic battery



Aseptic battery housing and battery funnel



**Figure 16**  
Universal Power components needed to use Vital Power

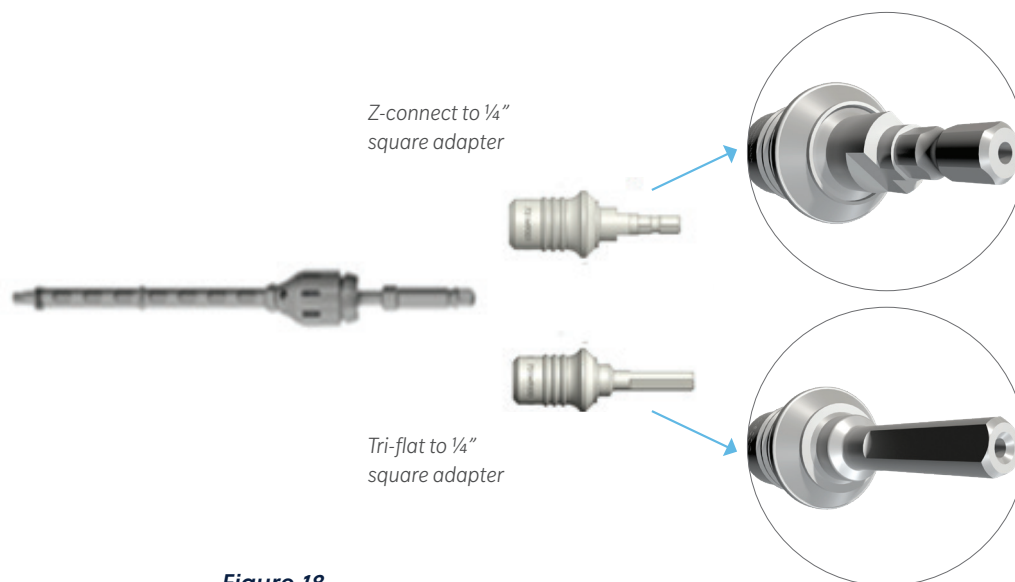
**Figure 17**  
Axial axial handle, Z-connect

### Vital Power Tap, Driver, and Universal Power System 250 RPM Zimmer/Hudson Attachment Assembly

All taps and drivers feature a Zimmer/Hudson Z-Connect mating feature for use with the Universal Power 250 RPM Zimmer/Hudson Attachment. Assemble the Universal Power Zimmer/Hudson Attachment with the handpiece in an identical manner to the Universal Power Small AO Attachment. Once the attachment and handpiece are assembled, pull back on the black collar of the attachment to insert the instrument (Figure 16).

**Note:** If needed, the Vital Power System includes a straight ratcheting handle that accepts Vital Power instruments that feature a male Universal Power Z-Connect (Figure 17).





**Figure 18**

## Vital Power Adapter Assembly with Universal Power System 250 RPM Zimmer/Hudson Attachment

The taps and drivers from the Vitality Preparation Instrument Kit (Kit #07.02136.401) feature male ¼" square proximal ends and may be used in conjunction with two ¼" square adapters that are found in the Vital Power Instrument Kit:

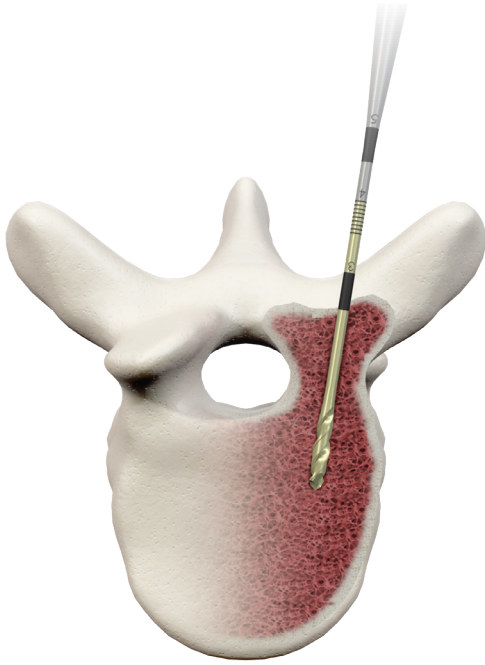
- Universal Power Z-Connect to ¼" Square Adapter
- Universal Power Tri-flat to ¼" Square Adapter

The Universal Power Z-Connect to ¼" Square Adapter is used with the Universal Power 250RPM Zimmer/Hudson Attachment. When using either the Universal Power Z-Connect to ¼" Square Adapters, or the Universal Power Tri-flat to ¼" Square Adapters; the Vitality instruments may be loaded into the ¼" square receiver, by pulling back on the adapter collar and firmly inserting the proximal end of the instrument until fully seated (Figure 18).

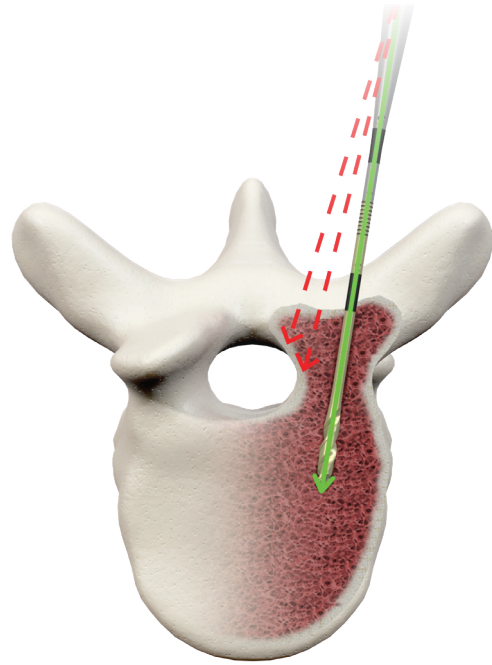
## Universal Power System and Vital Power Disassembly

To disassemble, pull on the attachment and/or adapter collars used for assembly and remove instruments. Press the two buttons located on either side of the handpiece's attachment receiver housing and pull the attachment out of the handpiece.

## Powered Pedicle Preparation and Screw Insertion



**Figure 19**  
Powered pedicle preparation – drill insertion



**Figure 20**  
Powered pedicle preparation – drill trajectory

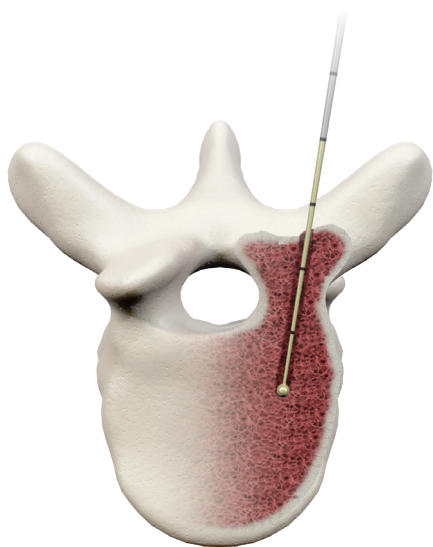
### Powered Pedicle Preparation

- Using the Universal Power Handpiece with Universal Power Small AO Attachment secured, insert either the Vital Power 2.4 mm pilot drill or the Vital Power 2.0 mm standard drill to the attachment, to create a pilot trajectory that follows the pedicle canal. These drills are recommended for initiating the pilot trajectory, as they allow the surgeon to use tactile feedback, to find the pedicle channel (Figures 19 and 20).
- The drill bit should be spun very slowly during insertion—approximately 1 to 3 rotations per second is recommended. In most cases, the weight of the handpiece is entirely sufficient, to ensure progression of the drill bit through the pedicle channel. If necessary, carefully apply minimal force to the handpiece, while maintaining the recommended rotational speed of the drill

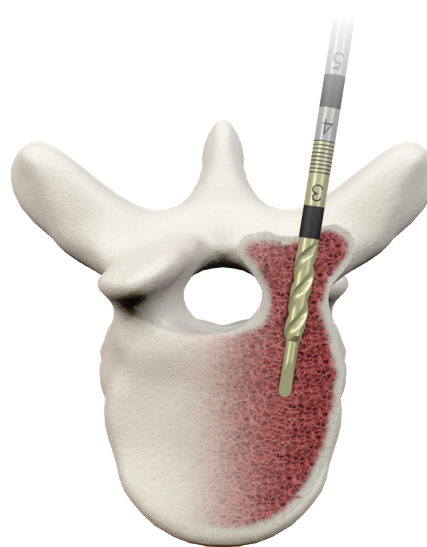
bit. By maintaining low RPM and applying minimal force to the handpiece during this process, the cortical bone of the pedicle resists the pilot drill more than cancellous bone, thus providing tactile feedback to the surgeon. Using this technique, the surgeon should be able to tactilely determine the path of least resistance through the pedicle's cancellous channel.

**Note:** Gentle application of pressure to the handpiece's trigger will give the desired speed. Some surgeons may find that paced, intermittent trigger presses of 1 to 2 seconds at a time, will help maintain low RPM and minimize downward pressure.

**Note:** The surgeon should ensure that the drill bit's trajectory is not inadvertently altered by soft tissue, while attempting to cannulate the pedicle. Therefore, it is important that the surgeon provide sufficient tissue retraction, when using either drill bit. As an example, the surgeon should take special care to provide adequate tissue retraction, when attempting pedicle screw preparation at highly rotated vertebral segments, the Lowest Instrumented Vertebra (LIV), the Upper Instrumented Vertebra (UIV), and when attempting promontory trajectories at S1. If the surgeon observes a bend in the shank of either drill bit; he, or she, may either alter their retractor placement, increase exposure, or use a pedicle probe for initial pedicle cannulation.



**Figure 21**  
Powered pedicle preparation – sounding



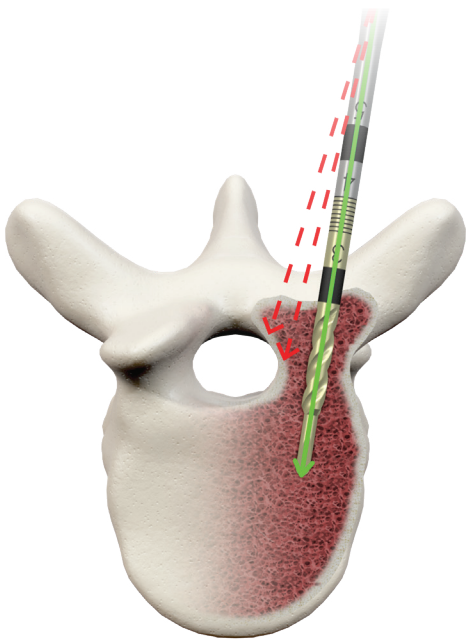
**Figure 22**  
Powered pedicle preparation – pedicle dilation

## Powered Pedicle Preparation and Screw Insertion

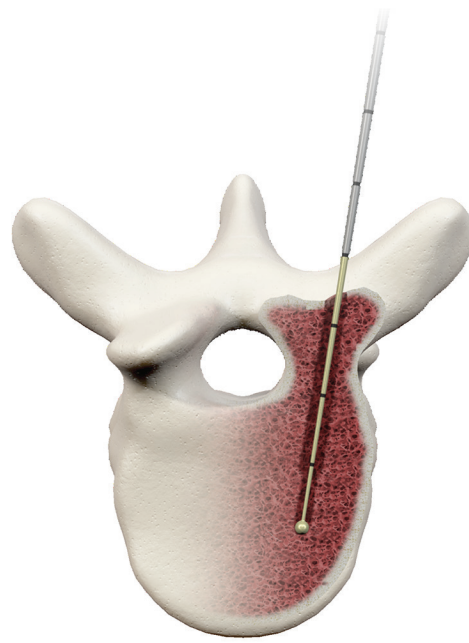
- Use a ball-tipped, sounding probe to confirm that the pedicle has not been breached and that the depth is appropriate (Figure 21).
- Secure either the Vital Power 3.0 mm reamer probe, or the optional Vital Power 3.2 mm reamer probe, to the Universal Power Small AO Attachment. Use the reamer to further dilate the channel that the pilot drill previously created through the pedicle canal. This reamer should self-center in the pilot hole created by the drill (Figure 22).

**Note:** The optional 3.2 mm reamer probe matches the inner diameter of the 5.5 mm Vital screw.

## Powered Pedicle Preparation and Screw Insertion (continued)



**Figure 23**  
Powered pedicle preparation - reamer trajectory



**Figure 24**  
Powered pedicle preparation - sounding

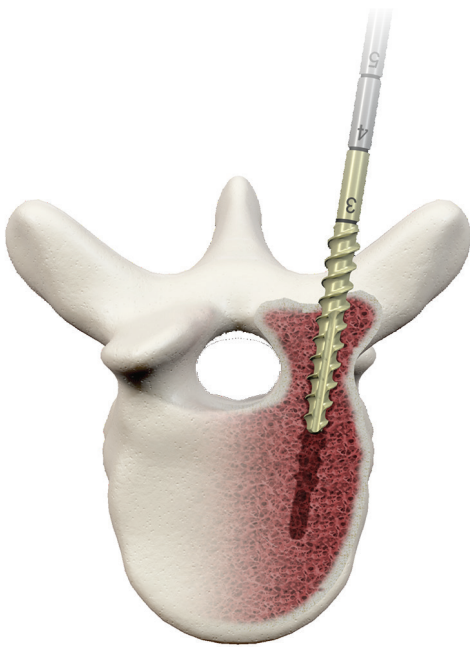
- As with the drill bit from the previous step, the reamer should be spun very slowly during insertion—approximately 1 to 3 rotations per second is recommended. Just as before, apply minimal force to the handpiece and reamer, when deemed necessary. In most cases, the weight of the handpiece is entirely sufficient, to ensure progression of the drill bit through the pedicle channel (Figure 23). By maintaining low RPM applying minimal force to the handpiece during this process, the cortical bone of the pedicle offers resistance to the blunted tip of the reamer more than cancellous bone and provides tactile feedback to the surgeon. Using this technique, the surgeon should be able to tactilely determine the path of least resistance through the pedicle's cancellous channel and establish the optimal path for pedicle screw insertion.

**Note:** Gentle application of pressure to the handpiece's trigger will give the desired speed. Some surgeons may find that paced, intermittent trigger presses of 1 to 2 seconds at a time, will help maintain low RPM and minimize downward pressure.

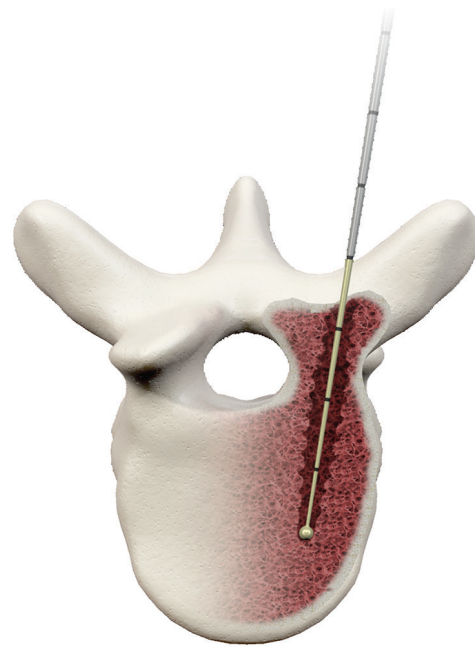
**Note:** The reamers have a larger diameter than the drills and will dilate the pedicle further in preparation of pedicle screw placement.

**Note:** If using a 6.5 mm screw or larger in hard bone, a pedicle probe may be used to further widen the channel. This step is only necessary for the first 20 mm of screw length, as the cancellous bone of the vertebra does not need to be widened.

- A ball-tipped, sounding probe may be used to check pedicle integrity, trajectory, and depth (Figure 24).



**Figure 25**  
Tapping



**Figure 26**  
Sounding probe check

## Optional: tapping

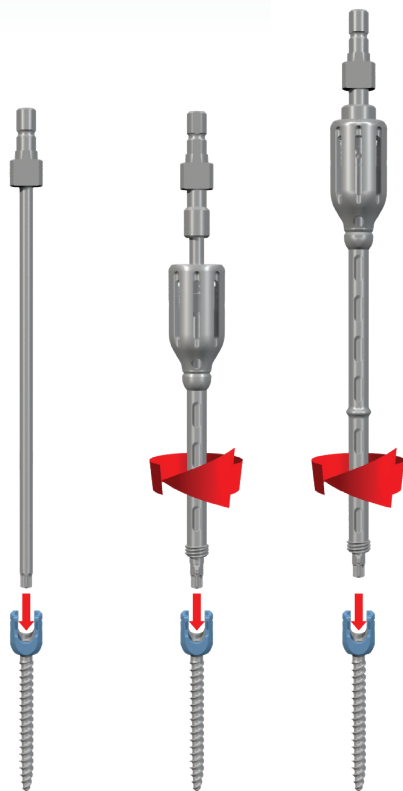
- Some surgeons may elect to use a tap following use of the Vital Power 3.0 mm blunt-tip reamer. There is an assortment of taps available in various diameters to accommodate these surgeons. Care should be taken to ensure that the tap is inserted slowly into the pedicle (Figure 25).
- A ball-tipped, sounding probe may be used to check pedicle integrity, trajectory, depth, and/or threads tapped into bone (Figure 26).

## Selecting Appropriate Pedicle Screw

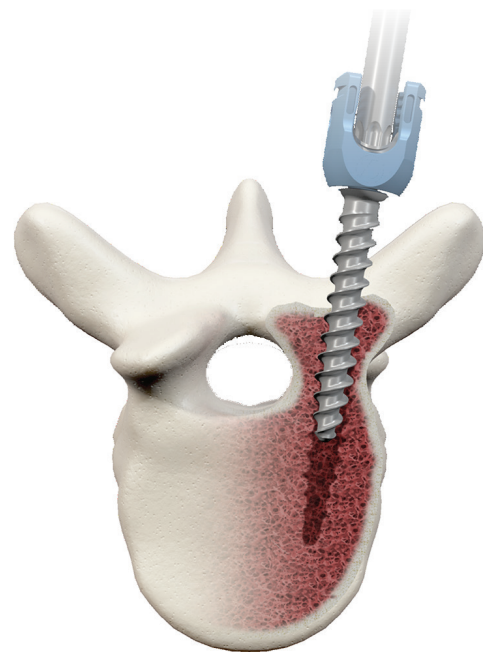
- Depending on the spinal pathology being treated, a surgeon may choose to utilize different types of pedicle screws.
- Polyaxial screws are generally the most commonly utilized screw.
- Uniplanar screws will most often be utilized at the apex of a scoliotic curve, because they are fixed in the medial-lateral plane. Uniplanar screws provide additional stability during vertebral body derotation maneuvers, to help restore global balance.
- Monoaxial screws can be utilized at the apex of a scoliotic curve as they also provide additional stability during vertebral body derotation maneuvers.

**Note:** It is recommended that reduction instrumentation is used when placing monoaxial screws at the end of a construct. This will ensure the rod is fully seated in the screw head prior to introducing and final tightening the closure top.

## Powered Pedicle Preparation and Screw Insertion (continued)



**Figure 27**  
Powered pedicle screw insertion - loading polyaxial, uniplanar, monoplanar, and iliac screws



**Figure 28**  
Powered pedicle screw insertion

### Pedicle Screwdriver Loading

The Vital Power Instrument Kit comes with a comprehensive range of pedicle screwdrivers to satisfy a variety of surgeon preferences.

Attach desired pedicle screw to chosen driver:

- 1 Secure Zimmer/Hudson Attachment to Universal Power Handpiece (not pictured).
  - 2 Secure proximal Universal Power Z-Connect end of the selected Vital Power screwdriver into the Universal Power Zimmer/Hudson Attachment (not pictured).
  - 3 Attach the screw to the selected Vital Power pedicle screwdriver by inserting the driver tip into the female T27 hexalobe on the screw shank. Make sure the screw shank is straight and aligned with the shaft of the inserter (Figure 27).
  - 4 For threaded, non-locking inserters, attach the screw by turning the driver's retention sleeve clockwise into the screw head.
  - 5 Optional: A free floating tissue sleeve may be placed anywhere along the shaft of the Vital Power stab-n-grab driver. The Vital Power stab-n-grab tissue sleeve will float freely and does not lock into place on the driver shaft.
  - 6 Optional: A blue, free-spinning tissue sleeve may be placed over the driver's threaded retention sleeve. The tissue sleeve must be placed onto the threaded, non-locking driver retention sleeve before the screw is attached.
- Use the handpiece to slowly drive the selected screw into the pedicle. The screw should self-center in pilot hole previously created (Figure 28).

## Vital Hooks Overview



**Figure 14**  
Laminar hook



**Figure 15**  
Narrow laminar hook



**Figure 16**  
Narrow reduced laminar hook



**Figure 17**  
Angled blade hook



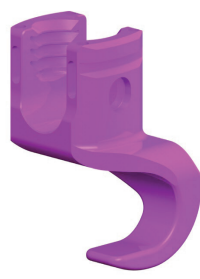
**Figure 18**  
Extended laminar hook



**Figure 19**  
Left angled hook



**Figure 20**  
Right angled hook



**Figure 21**  
Left offset hook



**Figure 22**  
Right offset hook



**Figure 23**  
Left transverse process hook



**Figure 24**  
Right transverse process hook

## Hook Placement

A wide selection of laminar hooks is included in the Vital Hook Implant and Instrument Kit, available for use in different anatomic locations, depending on surgeon need and patient anatomy. Each laminar hook is compatible with vertical, angled, and side hook holders.

The kit includes narrow reduced laminar hooks (Figure 16). These hooks are often placed in the thoracic spine, in a down-going fashion. They are often used at the end of a scoliotic curve's concavity, or in a rigid segment. These hooks prevent unnecessary crowding of the hook blade into the spinal canal.

The extended body laminar hooks are best used, in a down-going fashion in the mid-lumbar spine, to maintain the appropriate rod height at the proximal and distal aspects of the construct (Figure 18).

The system also features offset and angled laminar hooks (Figures 19-22). These hooks may

be placed in either an up-going, or down-going, fashion; to maintain co-linearity of the implant tulip. In some situations, particularly when a sub-adjacent pedicle screw is in place, the offset and angled laminar hooks are ideal to ensure that the hook tulip will meet the rod.

On some occasions the surgeon may desire to place hooks at one or more transverse processes. In these instances, the surgeon may find the transverse process hooks and the angled hooks advantageous, in order to ensure co-linear implant tulips along the construct (Figures 23 and 24).

**Note:** When placing down-going angled and offset hooks, left hooks are used on the right side and vice versa.

**Note:** Care should be taken to ensure that the bone captured by the hook completely fills the throat of the implant, preventing unnecessary penetration of the blade into the canal.

## Vital Hooks Overview (continued)



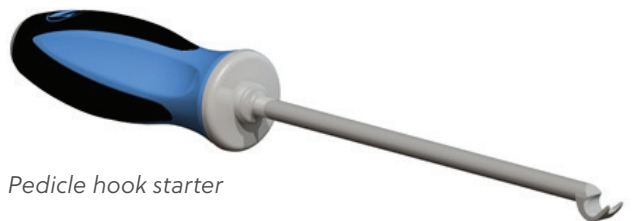
*Narrow laminar hook starter*



*Thoracic hook starter*



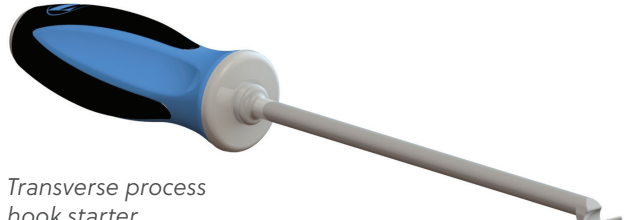
*Medium laminar hook starter*



*Pedicle hook starter*



*Wide laminar hook starter*



*Transverse process hook starter*

**Figure 25**  
*Assorted hook starters*

### Hook Starters

An assortment of hook starters is available in the Vital system (Figure 25). These instruments are designed to assist the surgeon in preparing the implant site and separating ligamentous attachments from bone prior to affixing a hook. These hook starters may be used to facilitate the placement of hooks using sublaminar, transverse process, and pedicle fixation techniques.





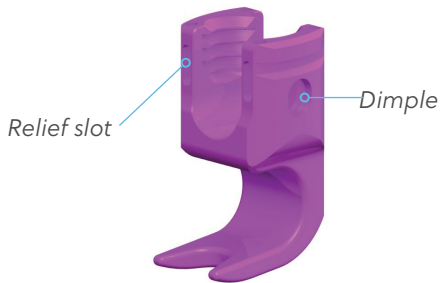
**Figure 26**  
Vertical hook holder



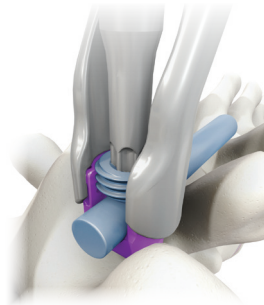
**Figure 27**  
Angled hook holder



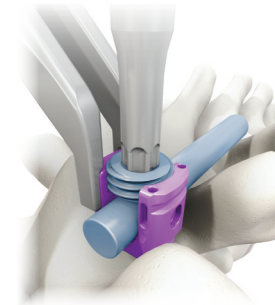
**Figure 28**  
Side hook holder



**Figure 29**  
Hook tulip relief slot and dimple



**Figure 30**  
Closure top introduced to hook,  
with angled hook holder attached



**Figure 31**  
Closure top introduced to hook,  
with side hook holder attached

## Hook Holders

- All hooks may be inserted using a vertical, angled, or side hook holder (Figures 26, 27, and 28).
- Attach the vertical and angled hook holders, via the dimples on the sides of the hook tulip (Figures 29 and 30).
- The side hook holder attaches to any hook in the system via ipsilateral relief slots found on the front and rear aspect of each tulip wall (Figures 31).

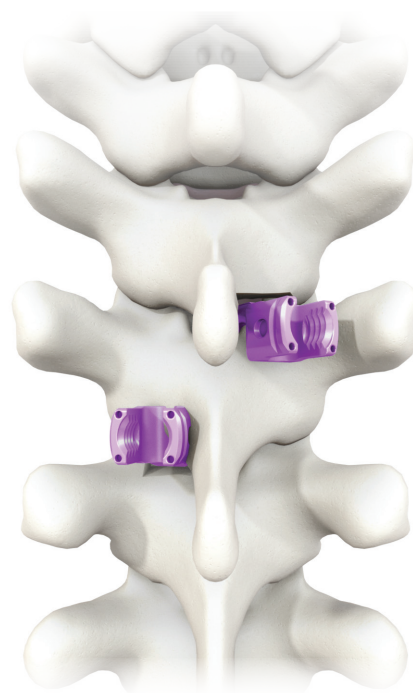
**Note:** A closure top can be pre-loaded into the hook's tulip before insertion, using any of the hook holders.

**Note:** The angled and side hook holders allow the surgeon to introduce, adjust, and remove a closure top, while the hook holder is still affixed to a hook (Figures 30 and 31).

## Surgical Techniques Using Hooks



**Figure 32**  
*Sublaminar hook site preparation using hook starter*

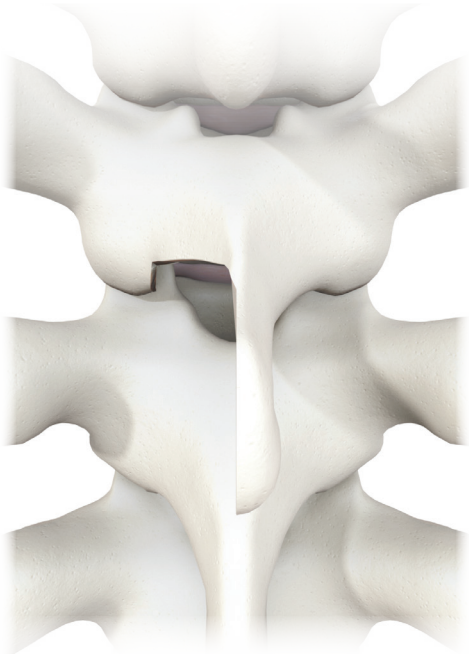


**Figure 33**  
*Supralaminar and infralaminar laminotomies*

### Sublaminar Hook Technique

---

- The surgeon may choose to use one of the Vital Hook starters to separate the ligamentum flavum from the lamina intended for hook fixation (Figure 32).
- In some instances, the surgeon may find it necessary to resect some of the bone surrounding the fixation site, via infralaminar and/or supralaminar laminotomies (Figure 33).



**Figure 34**  
*Partial spinous process resection and laminotomy*



**Figure 35**  
*Total spinous process resection*

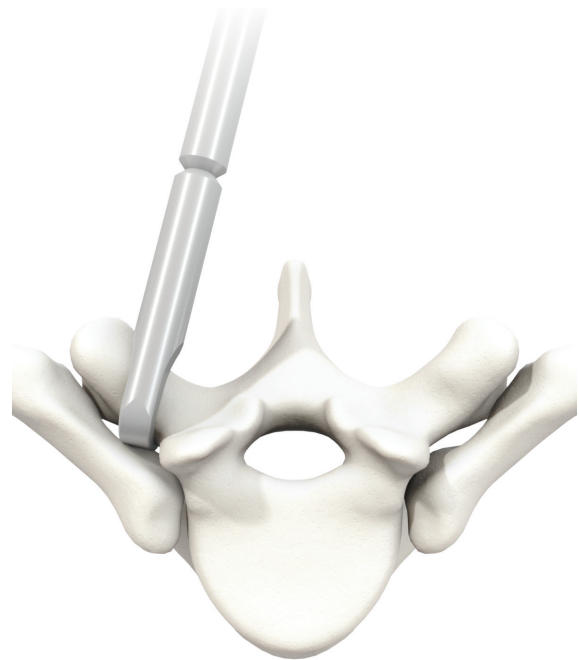
- The surgeon may also find the need to perform a partial, or total, removal of the superior spinous process. The shingle-like properties of thoracic lamina and their spinous processes can often require the surgeon use multiple resection techniques.
- Regardless of the resection techniques used, care should be taken to protect the integrity of the instrumented lamina in order to preserve fixation.

**Note:** When placing any instrumentation at the proximal end of a construct, take care to leave the interspinous ligament intact to avoid iatrogenic proximal junctional kyphosis.

## Surgical Techniques Using Hooks (continued)



**Figure 36**  
Transverse process preparation



**Figure 37**  
Transverse Process preparation – axial view

### Transverse Process Hook Technique

The transverse process hook technique is often used at the top of a thoracic construct. This technique is used when patient anatomy prevents pedicle screw insertion.

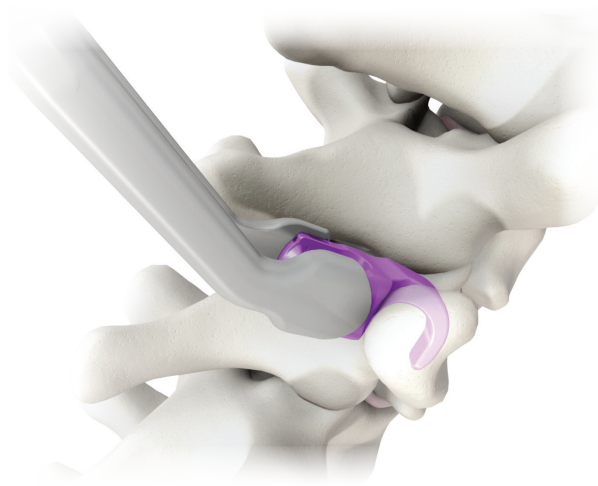
A transverse process hook technique is also particularly advantageous; when the surgeon requires a greater moment arm for leverage, to achieve the desired coronal correction at the upper instrumented level.

The left and right angled laminar hooks and transverse process hooks are ideal for transverse process hook placement, in either an up-going or down-going orientation.

- Use a laminar hook starter to separate the ligamentous attachments between the undersurface of the transverse process and the posterior arch of the rib, medial to the costovertebral joint (Figures 36 and 37).

**Note:** When placing any instrumentation at the proximal end of a construct, take care to leave the interspinous ligament intact to avoid iatrogenic proximal junctional kyphosis.

- After selecting the angled hook for implantation at the transverse process, place the hook on the desired hook holders.



**Figure 38**  
Angled hook holder with down-going angled or TP hooks

- When placing a down-going hook on a transverse process at the proximal end of the construct, some surgeons find it advantageous to attach the hook to an angled hook holder, so that the throat of the hook faces in the same direction as the bend in the holder (Figure 38).
- The surgeon may then leave the hook holder attached to the hook, thus angling the handle away from the incision site. This technique also helps guide the rod into the hook's tulip and allows the surgeon to introduce a closure top without removing the holder.



**Figure 39**  
Hemifacetectomy

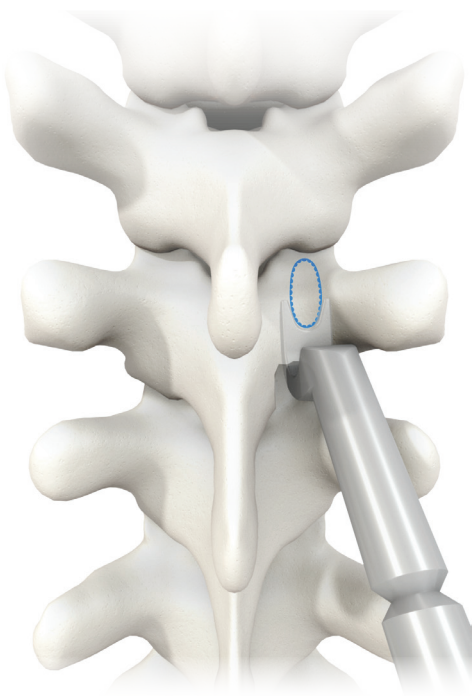
## Pedicle Hook Technique

In instances where the surgeon encounters difficult pedicle anatomy, it may be determined that a pedicle hook is appropriate in order to gain fixation at a particular vertebral level.

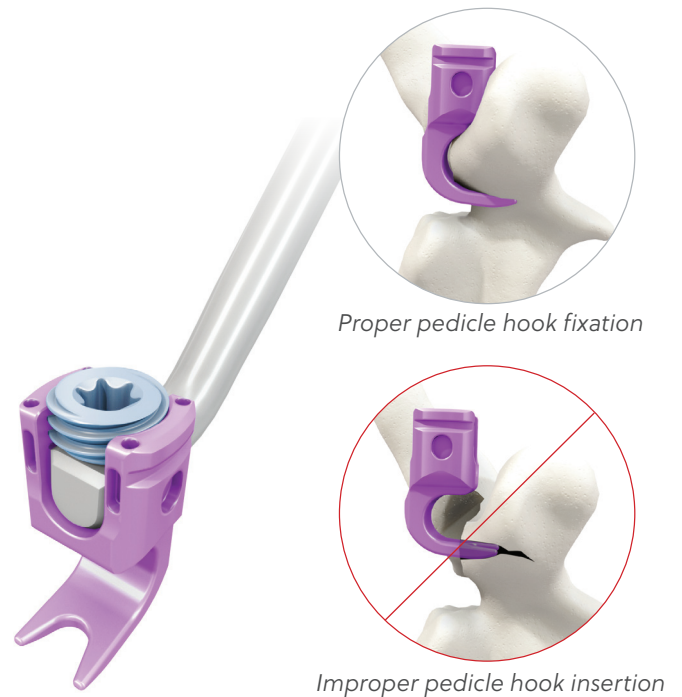
In some instances, a portion of the inferior articular process may be removed to facilitate insertion of the hook.

- This is done by making two cuts on the superior vertebra's inferior articular process at the motion segment to be instrumented.
- First perform a superior-to-inferior cut at the lateral margin of the ligamentum flavum, 2-3 mm proximally. The second cut is made in a transverse plane from the lateral edge of the facet to the medial cut. Approximately 6 mm of the inferior vertebra's superior articular process should remain, when measured from the base of the transverse process.
- Remove the osteotomized bone and curette the facet cartilage.

## Surgical Techniques Using Hooks (continued)



**Figure 40**  
Pedicle hook site preparation with pedicle hook starter



**Figure 41**  
Hook impactor used for pedicle hook insertion

### Pedicle Hook Technique (continued)

In some instances, with a hook of sufficient size the surgeon may simply choose to forgo a hemifacetectomy and instead simply divide the facet capsule and begin pedicle hook site preparation.

- A pedicle hook starter may be used from T1 to T10. Place the hook blade cephalad in the infralaminar position (Figure 40).
- Once the pedicle has been clearly identified with the help of the pedicle hook starter, the hook may be inserted.

**Note:** Use caution to prevent medial penetration of the canal with the pedicle hook starter.

A pedicle hook may be inserted using the hook impactor. The impactor is designed to seat in the hook's tulip.

- After seating the impactor's distal end in the hook's tulip, insert a closure top and tighten, securing the hook to the impactor (Figure 41). Gently mallet the proximal end of the hook impactor to insert and seat the pedicle hook.
- If the surgeon chooses not to use a mallet, a hook holder may be attached to the hook for extra control and the hook may be pushed into place by hand using the grip of the hook impactor.

**Note:** It is important that the pedicle hook not split any of the bony anatomy as it is inserted.



**Figure 42**  
Claw hook construct

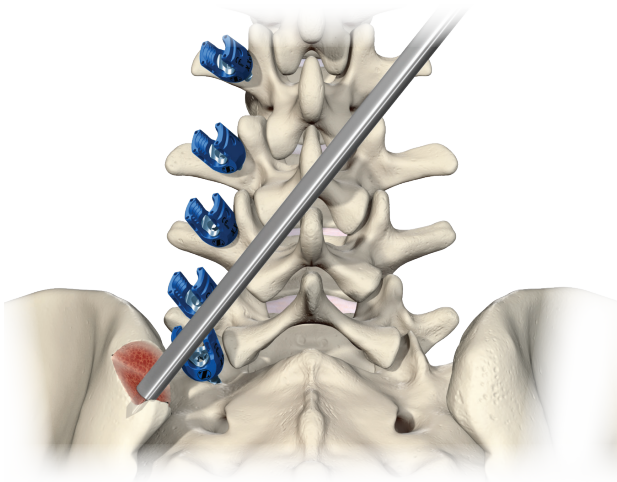
### Transverse Process and Pedicle Hook "Claw" Technique

- A down-going hook placed on the transverse process and a pedicle hook may be used in a "claw" hook construct (Figure 42). This technique allows for a greater degree of coronal correction, through compression and distraction of the levels captured by the claw construct and those levels adjacent to them.
- Use an angled hook in a down-going fashion on the transverse process at the level below an implanted pedicle hook. At this point the surgeon can compress and distract as needed on and against these fixation points, in order to gain the desired coronal correction.

### Iliac Fixation

In some instances, such as neuromuscular scoliosis with pelvic obliquity, or when additional fixation is necessary to load share at the lumbosacral junction, iliac fixation may be valuable. The iliac wing and posterior superior iliac spine are exposed by the surgeon's preferred method. The iliac wing is typically exposed enough to orient the path of the iliac screw to ensure that the iliac cortex is not violated during placement of the iliac screw. Place the pelvic probe down between the iliac tables in a manner that places the path about 1.0 cm to 1.5 cm above the greater sciatic notch. The pelvic probe placement and trajectory can be confirmed with fluoroscopy of the pelvis or by tactile feedback, depending on the surgeon's standard protocol. The screw is placed after the inner and outer tables are palpated with a ball-tipped probe and the iliac walls and floors are noted to be intact. It is recommended to notch the iliac wing around the screw head to sink the screw head to prevent prominence.

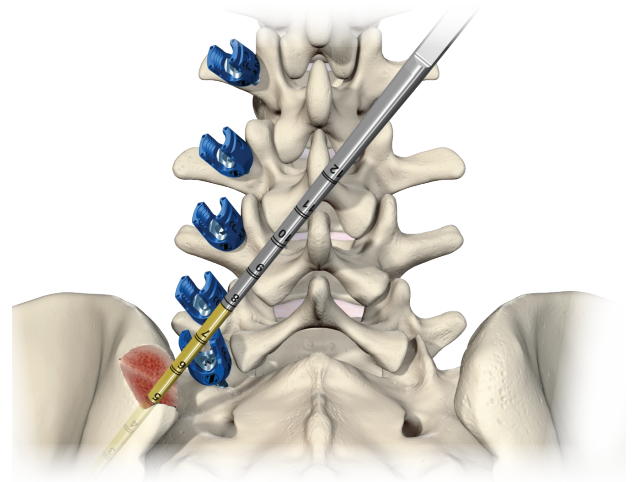
## Optional Iliac Fixation (continued)



**Figure 43**  
*Iliac screw prep - awl*

### Awl

- After selecting the entry point, use the awl to pierce the bone cortex and create a pilot hole.

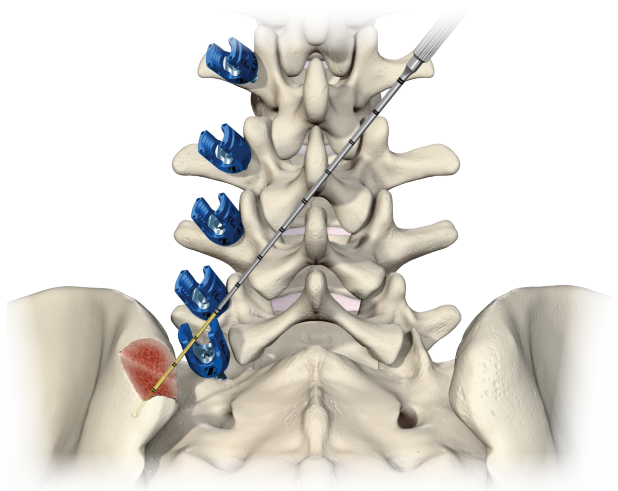


**Figure 44**  
*Iliac screw prep - probe*

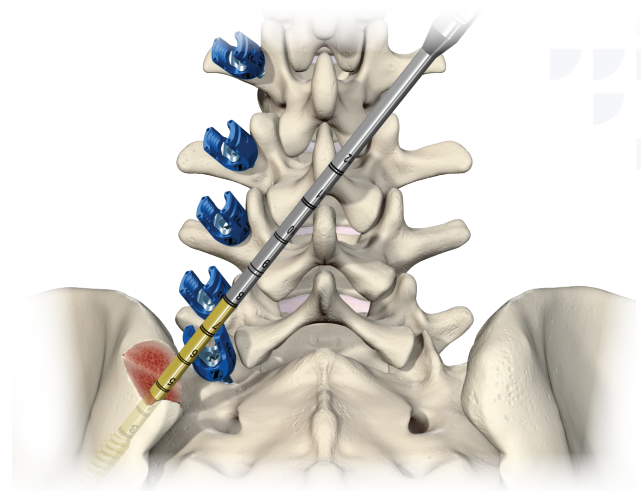
### Iliac Probe

- Determine the optimal trajectory of the screw pathway based on the patient's anatomy. Insert the iliac probe through the pilot hole into the ilium to create a path to guide the screw. Reference the depth indicators on the Iliac.
- Probe shaft to ensure the probe reaches the desired depth.





**Figure 45**  
Iliac screw prep - sounding



**Figure 46**  
Iliac screw prep - tapping

## Confirm Pathway Integrity

- After removing the iliac probe, verify the integrity of the cortical walls by using the ball-tip probe. When fully inserted, forceps can be clamped onto the ball tip probe to mark the hole depth and assist in iliac screw selection.

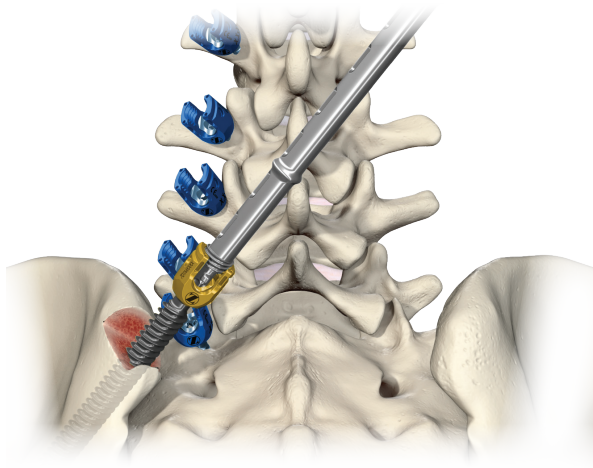
## Tapping

- Connect the appropriate diameter iliac tap to the desired handle. Insert the iliac tap into the ilium and advance the threads by rotating the handle clockwise.
- After removing the tap by rotating the instrument counterclockwise, verify the integrity of the cortical walls again using the ball-tip probe.

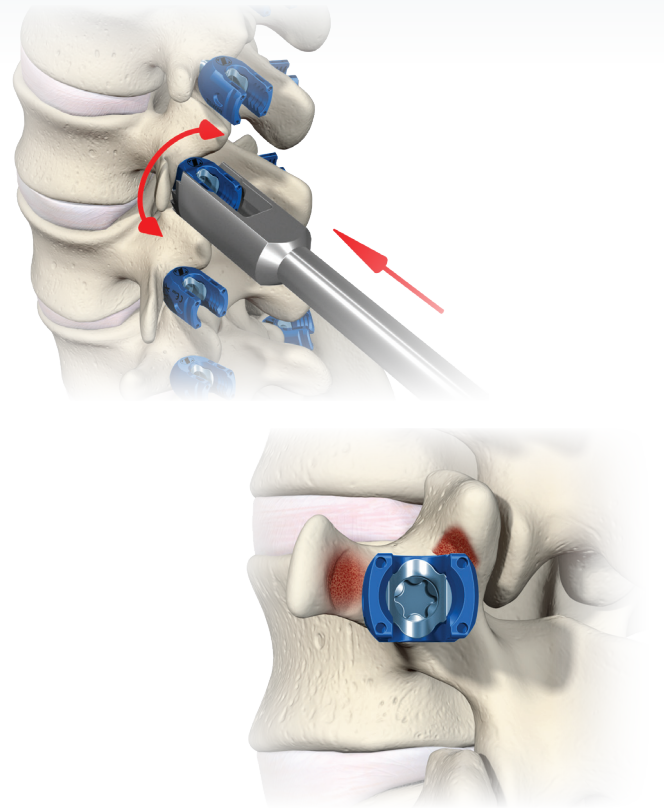
**Note:** The Vital system offers taps that are true to labeled size – i.e. line-to-line.

**Note:** Guidewires and cannulated taps may be used in conjunction with each other, if so desired. Cannulated open iliac screws are also available, should the surgeon need these implants. Additional information regarding guidewire insertion and use with cannulated instruments and implants can be found in the Vital MIS Surgical Technique Guide as needed.

## Optional Iliac Fixation (continued)



**Figure 47**  
*Iliac screw insertion*



**Figure 48**  
*Bone planer*

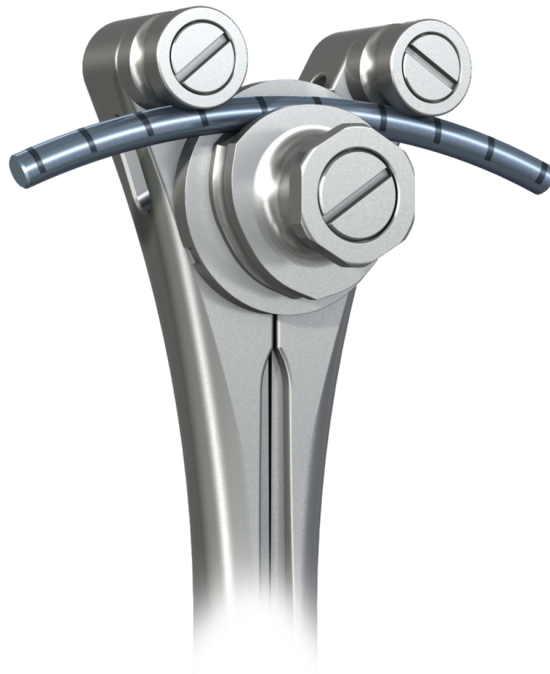
### Screw Insertion

- Attach the appropriate size iliac screw to the screwdriver assembly. Insert the iliac screw into the pilot hole and advance it to the desired dorsal height by turning the standard screwdriver clockwise.
- To release the screwdriver, push the retention collar button and pull the collar toward the handle. Turn the sleeve counterclockwise to loosen the screwdriver from the tulip head.
- After removing the iliac probe, verify the integrity of the cortical walls by using the ball-tip probe. When fully inserted, forceps can be clamped onto the ball-tip probe to mark the hole depth and assist in iliac screw selection.

### Bone Planing Around Screw

- The bone planer is used to remove bone before or after the rod is introduced (e.g., base of thoracic transverse process or lamina) that may be hindering engagement of instruments onto the screw, particularly when introducing the rod (Figure 48).

## Rod Insertion and Provisional Tightening



**Figure 49**  
French bender

### Rod Selection and Bending

The Vital system offers multiple rod diameter and material choices. Surgeons should select the rod that is appropriate for their patient's needs. The system includes a rod template that can be used to determine rod length and desired contour. The rod template should be inserted into screw heads and contoured to fully seat within the screw head. Appropriate length can be determined using the length markings on the rod template. Use the French rod bender to prepare and contour the rods with progressive bends until obtaining a shape similar to that defined by the rod template (Figure 49). Pre-contoured versions simplify the initial approximation.

**Note:** The surgeon should reference the markings on the rod to achieve contours in the desired place.

The variety of stiffness and strength combinations of rods allow the surgeon to tailor the construct to the surgeon's preference according to the needs of the patient. As with any metal, rods

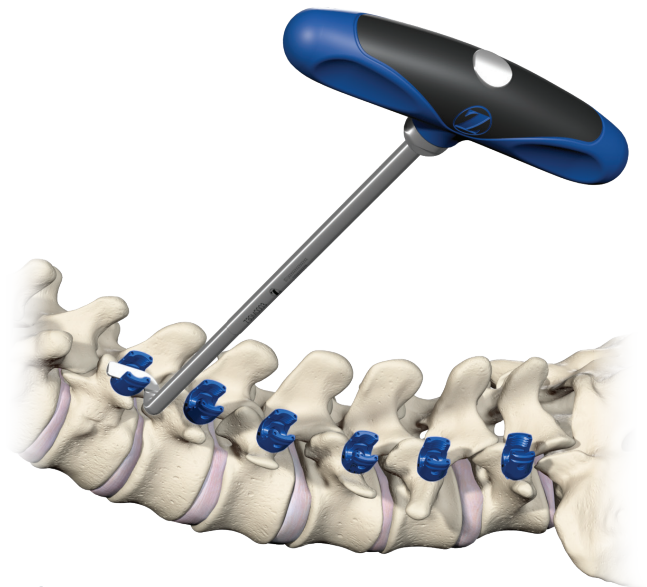
should be bent with caution and minimally to prevent fracture and fatigue. The use of cobalt chrome alloy rods with titanium implants (screws, closure tops, and hooks) maintains imaging capabilities. The rods include two longitudinal lines along the length of the rod to help determine the correct plane and reference when bending and inserting the rod. These markings also aid in rod rotation. The rods also incorporate medial-lateral rod markings every 10 mm and are intended to allow the surgeon to observe how much compression and distraction is achieved during these rod adjustments. The rods incorporate two hex ends for further options with rod rotation.

**Note:** The surgeon should reference the markings on the rod to achieve the desired contour. The rods in the Vital Spinal Fixation System feature both longitudinal and horizontal markings, to assist the surgeon during the contouring process by helping to ensure that the rod is contoured in the desired plane.

## Rod Insertion and Provisional Tightening (continued)



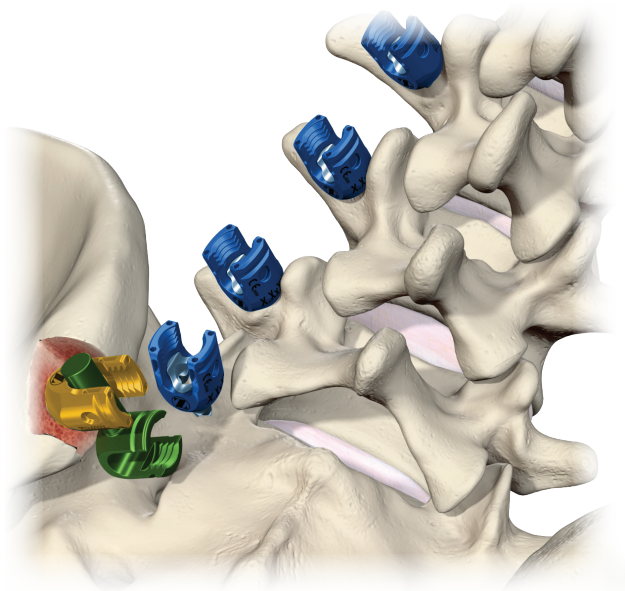
**Figure 50**  
Head height adjuster



**Figure 51**  
Mono/fixed head height adjuster

### Screw Adjustment / Rod Insertion

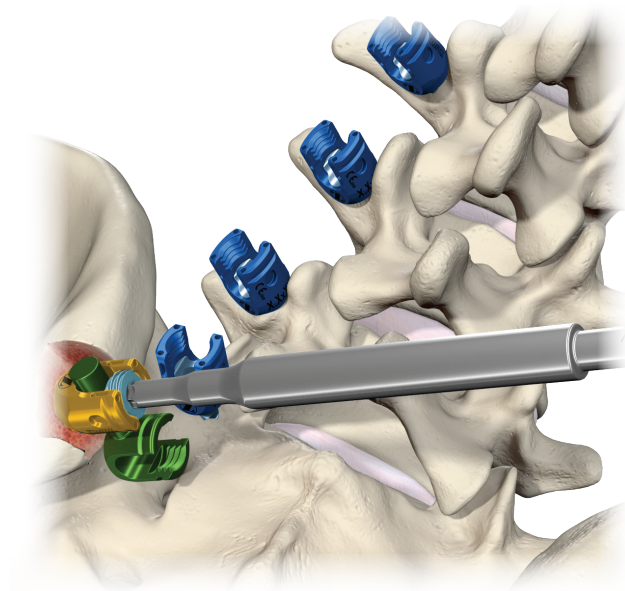
- The head height adjuster can be used to adjust screw head alignment prior to rod insertion. To adjust screw height, fully insert the male T27 interface of the head height adjuster into the female T27 recess in the screw shank and turn until the screw head has reached the desired height (Figure 65). To simply adjust the screw head orientation, without adjusting the height of the implant, partially insert the distal end of the instrument into the head of the screw, without engaging the T27 interface. Turn to ensure screw heads are in proper orientation for rod insertion. Use the rod holder, rod gripper, or vise grips to provisionally position the rod within the screw heads. With longer constructs, the surgeon may simply choose to introduce the rod by hand.
- A mono/uniplanar screw head/height adjuster is also available in the Vital System. The end of this instrument is contoured to allow the surgeon to manipulate the monoaxial, or uniplanar, screw head when the rod, or other instrumentation might prevent the engagement of a standard head height adjuster (Figure 51).



**Figure 52**  
Posterior superior iliac spine (PSIS) fixation with open lateral offset connector

### Lateral Offset Connector Placement

- Open or closed lateral offset connectors are utilized to facilitate rod placement and bridge the construct between the iliac screw and rod (Figure 52). Determine the appropriate open or closed lateral offset connector. Place the lateral offset connector in the screw head of the open or closed iliac screw in a preferred orientation. Both open and closed lateral connectors options are available in straight (0°), or 15° and 25° angles.



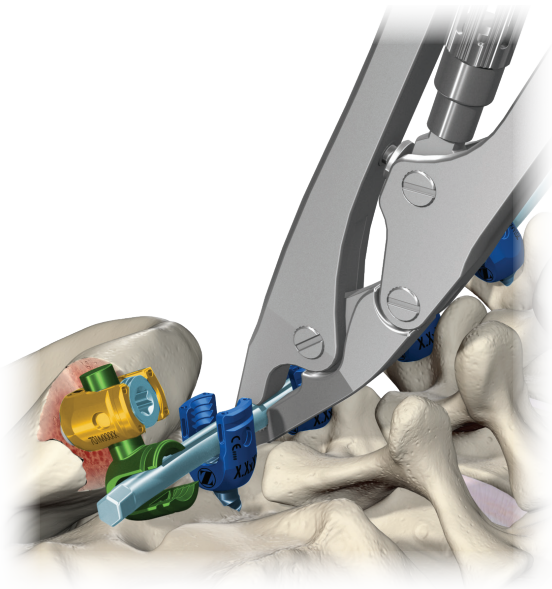
**Figure 53**  
Provisional tightening of open lateral offset connector in iliac open iliac screw for PSIS fixation

### Closure Top Placement — Iliac Screws

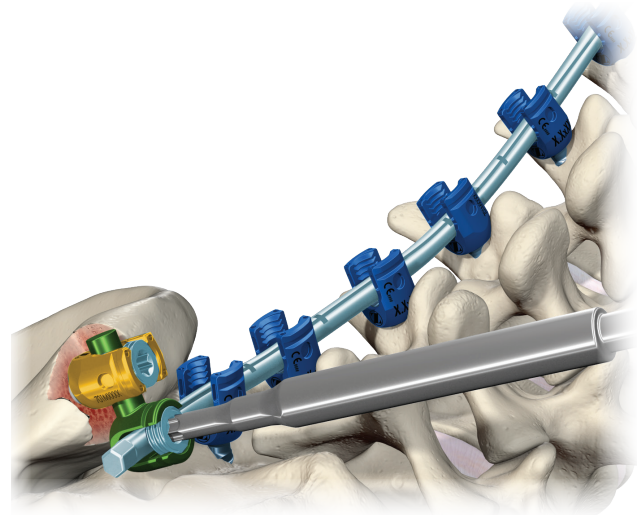
- While holding the lateral offset connector in place, insert a closure top and provisionally tighten the closure top on the tulip head of the iliac screw with the closure top starter (Figure 53).

**Note:** At least 2 mm of the offset connector rod should extend beyond the tulip head before tightening the closure top.

## Rod Insertion and Provisional Tightening *(continued)*



**Figure 54**  
*Seating rod in open lateral offset connector*



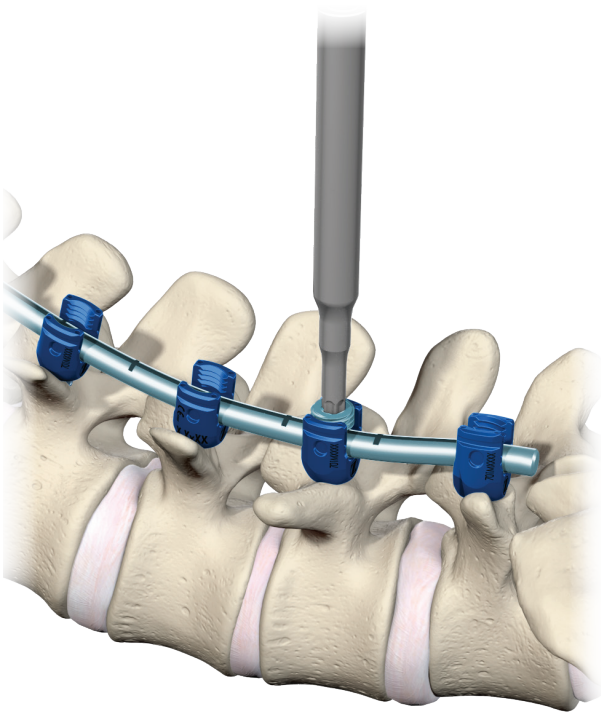
**Figure 55**  
*Provisionally securing rod into open lateral offset connector*

### Iliac Screw + Lateral Connector: Rod Insertion

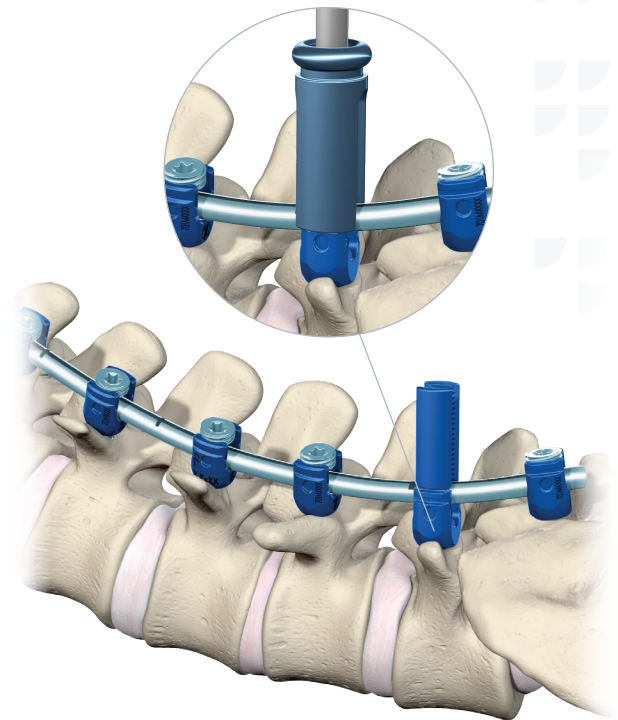
- Use the rod holder, rod gripper, or vise grips to provisionally position the rod within the screw heads. With longer constructs, the surgeon may simply choose to introduce the rod by hand.
- Select the appropriate length rod and cut to a desired length. Rods may be bent to facilitate placement. Place the rod in the lateral offset connector, followed by each remaining cephalad pedicle screw (Figure 54).

### Closure Top Insertion — Lateral Offset Connectors

- Provisionally tighten the closure top in the saddle of the lateral offset connector with the closure top starter (Figure 55).



**Figure 56**  
Closure top insertion and provisional tightening



**Figure 57**  
Reduction screw tab sleeve used during closure top insertion and provisional tightening

### Provisional Tightening

- Insert the T27 provisional driver or dual-ended closure top starter into the hexalobe drive interface of the closure top.
- Align the driver with the screw head and introduce the closure top. Turn the closure top until it meets the rod. Do not final tighten (Figure 56).
- Repeat this procedure for inserting all closure tops.

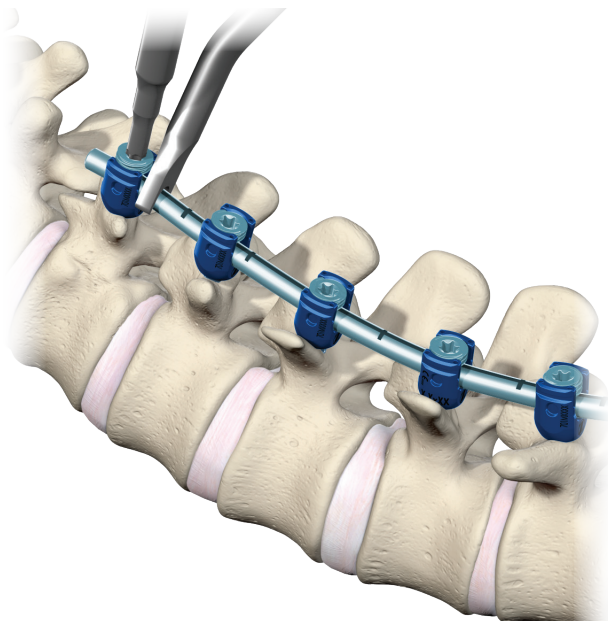
### Option 1: Reduction Screws

- Insert the rod into the reduction screw head. When using reduction tab screws, reduction tab sleeves must always be used to protect the reduction tabs during rod manipulation and to ensure closure tops thread into the screw tulips properly.
- After the rod is placed within the screw head, slide the reduction tab sleeve over the reduction screw head (Figure 57). Use the T27 provisional starter to insert the closure top into the reduction screw.

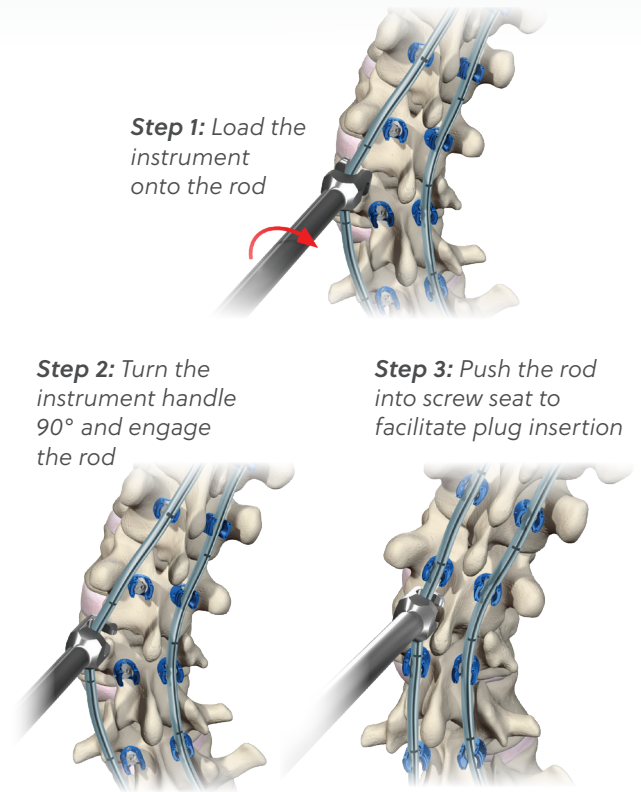
**Note:** Shear-off closure tops are not compatible with reduction screws.

- Using the closure top starter, advance the closure top until the rod is fully seated and the closure top is provisionally tight. Remove the reduction tab sleeve.

## Reduction Instrumentation (continued)



**Figure 58**  
Rod pusher



**Figure 59**  
Rod manipulator used to seat rod

### Option 2: Rod Pusher

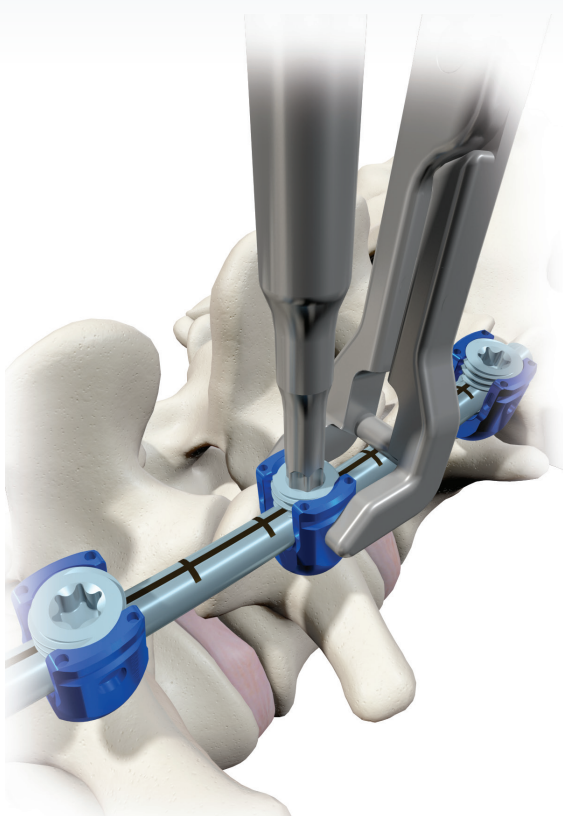
- For slight reduction, the rod pusher can be used to directly introduce the rod into the screw head. Use the closure top starter or dual ended closure top starter to introduce the closure top into the screw head. Turn the closure top until it meets the rod. Do not final tighten (Figure 58).

### Option 3: Rod Manipulator

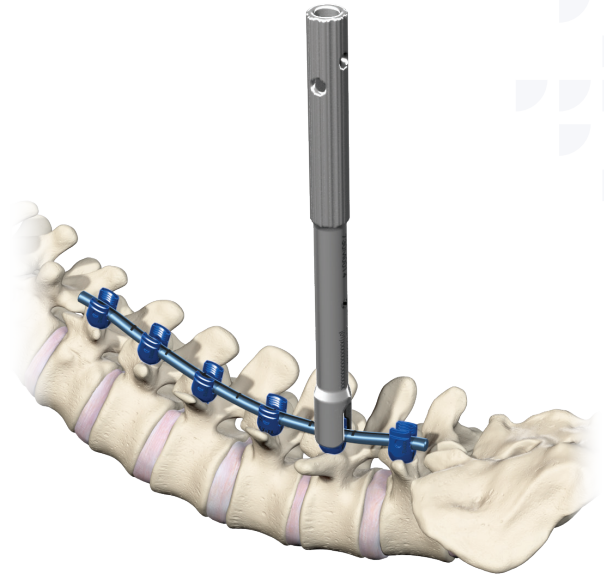
- The rod manipulator is used to persuade the rod into the tulip and can move the rod cephalad/caudal, medial/lateral. First place the manipulator on the rod, turn the handle 90° clockwise to lock the instrument to the rod, push, pull, or translate the rod into the seat (Figure 59). Provisionally place the closure top into the tulip, turn the handle 90° counterclockwise to release the manipulator and lift up.

**Note:** Be cautious as to potential bone that may be underneath the instrument that may hinder the application and release of the instrument. If this occurs, use a different rod reduction option or remove the bone with the bone planer.





**Figure 60**  
Rod rocker used to seat rod.



**Figure 61**  
Tube rod pusher

### Option 4: Rod Rocker

- For moderate reduction, the rod rocker may be used. Align the prongs of the rod rocker in the medial and lateral slots on the screw head. Close and lock the rod rocker and use the rod rocker as a lever to introduce the rod into the screw head (Figure 60). There are two different rod rockers available in the Vital system—a standard short throw rocker in the Vital Implant Kit and a long throw rocker found in Complex Instrument Kit 2.
- Once the rod is fully reduced into the screw head, use the T27 provisional driver or dual-ended closure top starter to introduce the closure top into the screw head. Turn the closure top until it meets the rod. Do not final tighten.

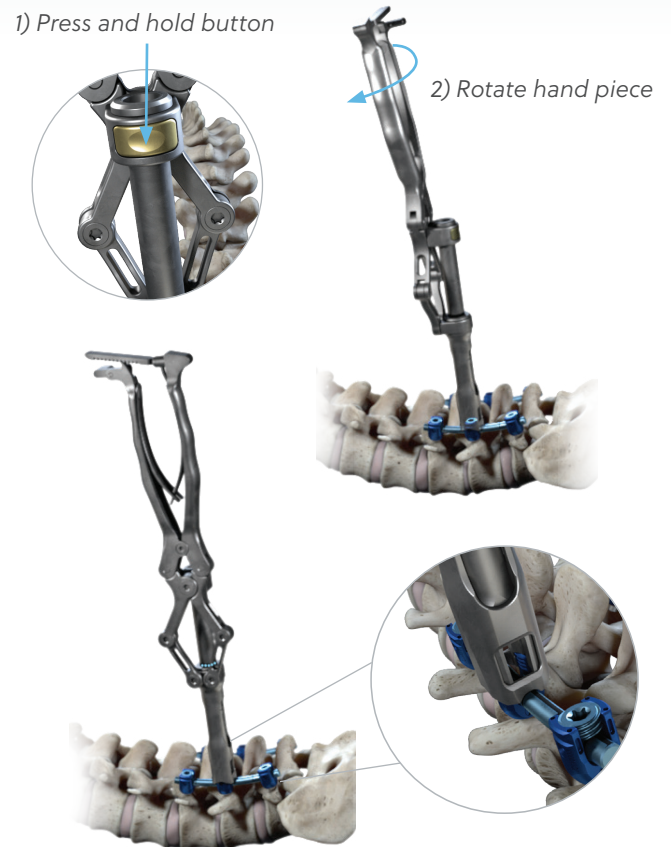
### Option 5: Tube Rod Pusher

- The tube rod pusher can be used to align the rod with the screw head. Position the tube rod pusher over the rod and manipulate alignment to the screw head. Once the rod is positioned within the screw head, use the rod pusher to position the rod into the screw head (Figure 61).
- Use the closure top starter or dual ended closure top starter to introduce the closure top into the screw head. Turn the closure top until it meets the rod. Do not final tighten.

## Reduction Instrumentation (continued)



**Figure 62**  
Closure top starter - reducer



**Figure 63**  
Single action reducer

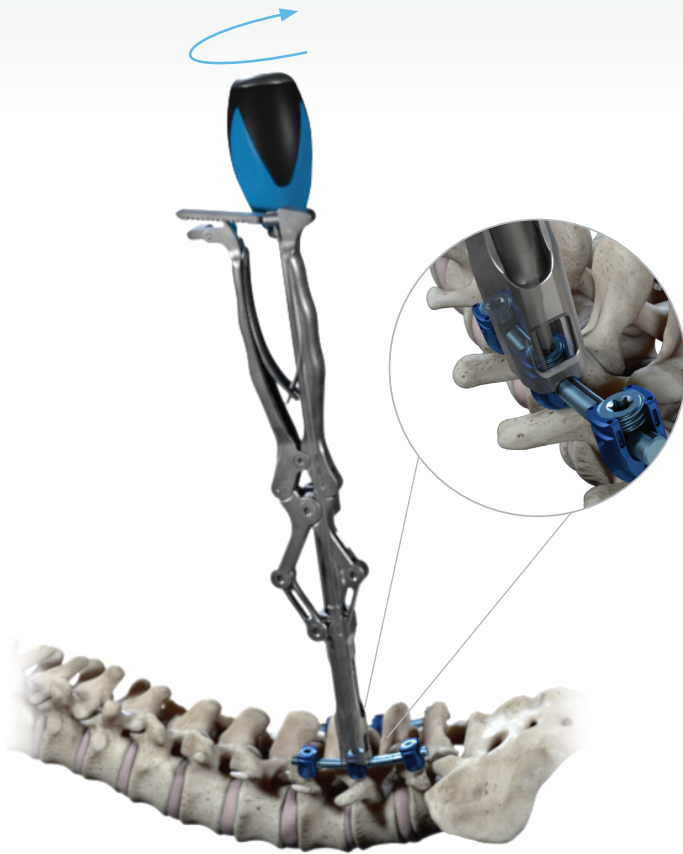
### Option 6: Single Action Rod Reducer

- When the rod is above the screw head, the single action rod reducer may be used to seat the rod. Ensure the reducer is fully open and engage the cephalad and caudal relief slots of the screw head by pressing the single action rod reducer down gently onto the screw head.
- Slowly squeeze the handles together, sliding the external sleeve down to seat the rod into the screw head. The ratchet allows controlled reduction and maintains position until the closure top is placed.

**Note:** The single action rod reducer offers 20 mm of reduction capability.

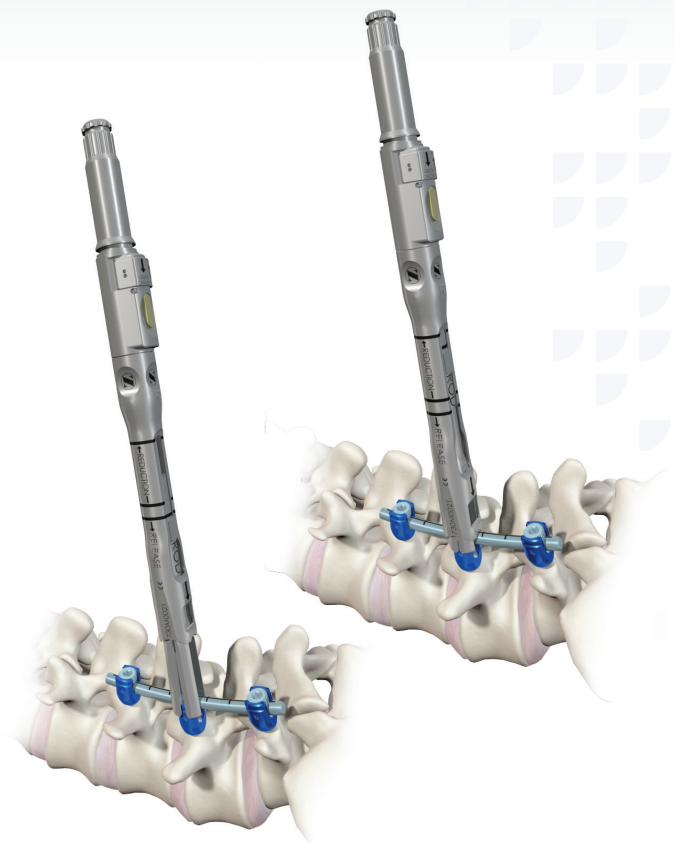
- Once the rod is fully reduced into the screw head, use the closure top starter - reducer to introduce the closure top into the screw head (Figure 62).

The orientation of the handles may be changed before, or after attaching to the implant by simply pressing the gold button on the front of the instrument and rotating the handles 90° (Figure 63).



**Figure 64**  
Closure top introduction through single-action reducer

- Once the rod is fully reduced into the screw head, use the closure top starter - reducer to introduce the closure top into the screw head (Figure 64). Turn the closure top clockwise until it meets the rod. Do not final tighten.
- To remove the single action rod reducer, release the ratchet, open the handles and disconnect the Reducer from the screw head.



**Figure 65**  
Attaching and priming tower reducer

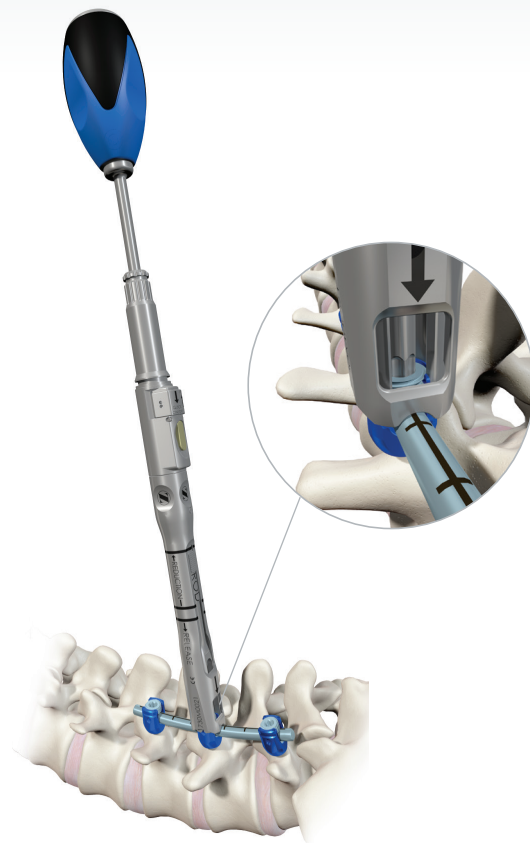
### Option 7: Tower Rod Reducer

- Engage the four vertical slots cephalad and caudal by gently setting the tower reducer onto the screw head.
- Press and hold the tower reducer's gold button and advance the tower reducer by pushing downward until the reduction anvil meets the rod (Figure 65).

## Reduction Instrumentation (continued)



**Figure 66**  
Rod reduction using tower reducer



**Figure 67**  
Closure top introduction and provisional tightening

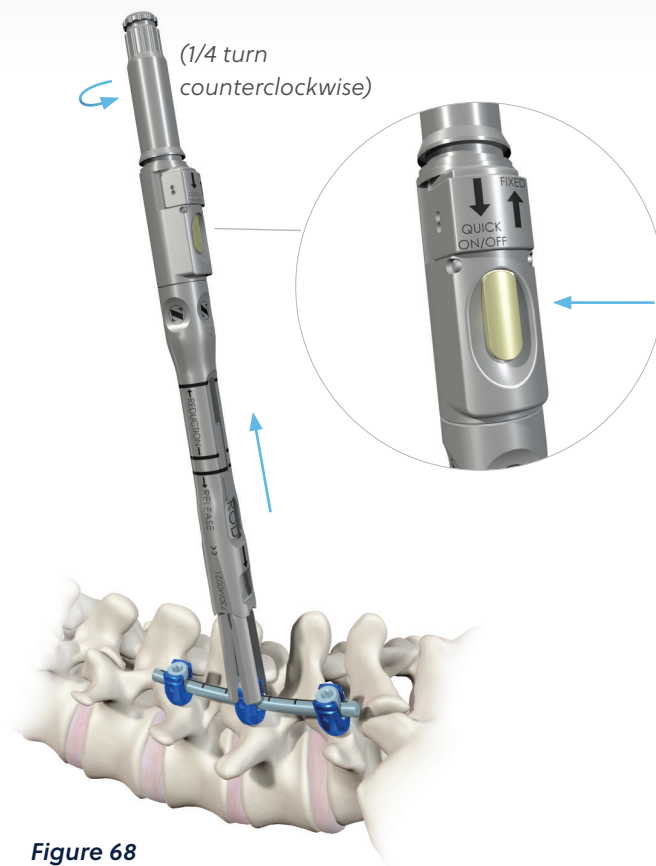
### Option 7: Tower Rod Reducer (continued)

- Rotate the top sleeve clockwise until the rod is fully reduced into the screw head. The tower reducer offers 30 mm of reduction capability.
- Confirm the rod is fully reduced by looking at the laser mark reduction lines on the outer sleeve (Figure 66). The inner and outer sleeve lines should match when the rod is fully reduced.
- Once the rod is fully reduced into the screw head, use the T27 provisional driver to introduce the closure top into the screw head. Turn the closure top until it meets the rod. Do not final tighten (Figure 67).

**Note:** For additional leverage during the reduction maneuver, attach the tower reducer T-handle to the top of the reducer by pressing the gold button and sliding over the top of tower reducer.

The short quick connect adapter (attached to preferred handle) can be utilized to reduce the screw to the rod.

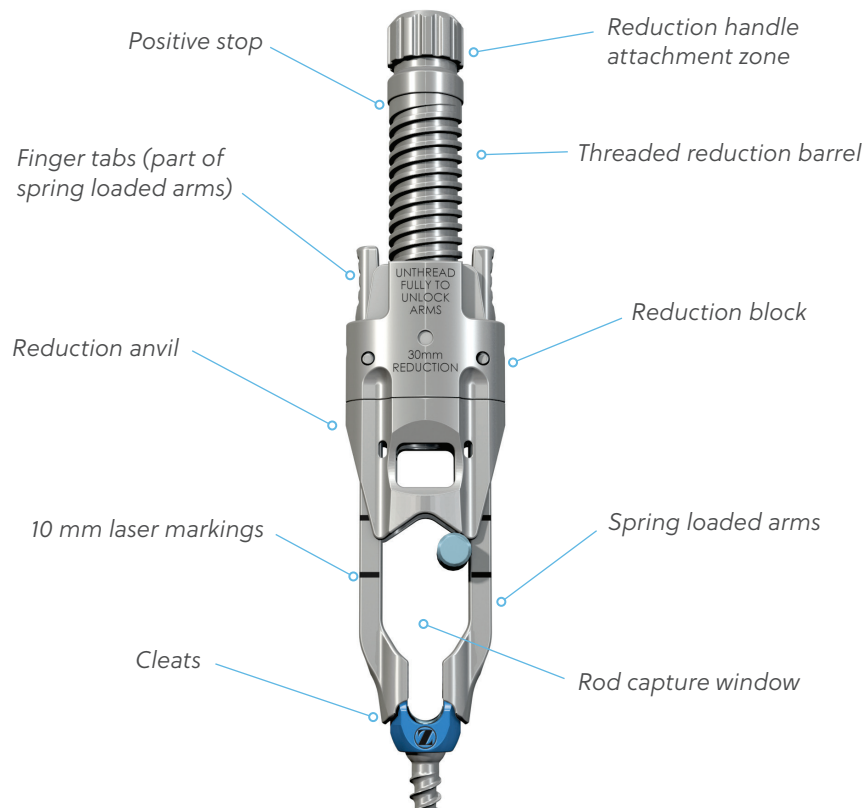




**Figure 68**  
Removing tower reducer

- To remove the tower reducer, turn the handle a  $\frac{1}{4}$  turn counterclockwise, push and hold the gold button at the proximal end of the reducer and gently lift the tower reducer off of the screw head (Figure 68).

## Reduction Instrumentation (continued)



**Figure 69**  
Rocket reducer

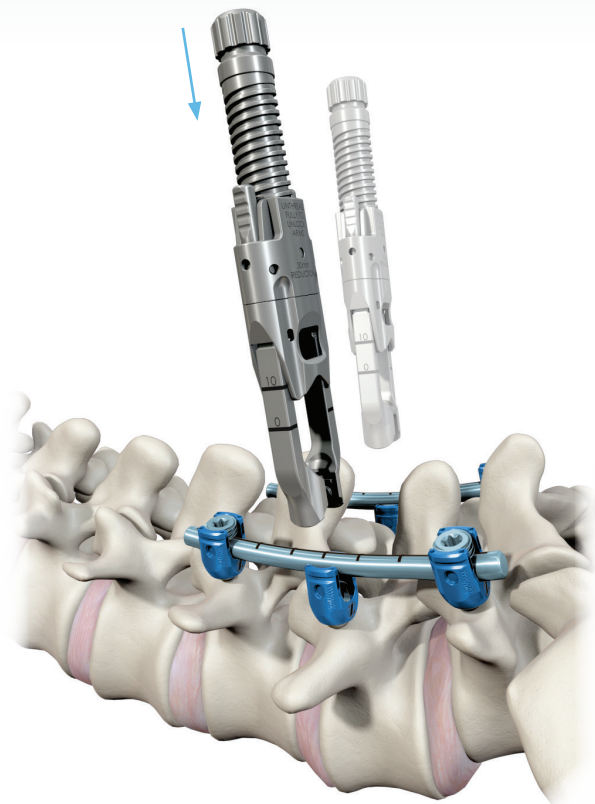
### Option 8: Rocket Reducer

The short rocket threaded reducer provides simultaneous rod translation and reduction. Its design features guide a rod into proper screw head position.

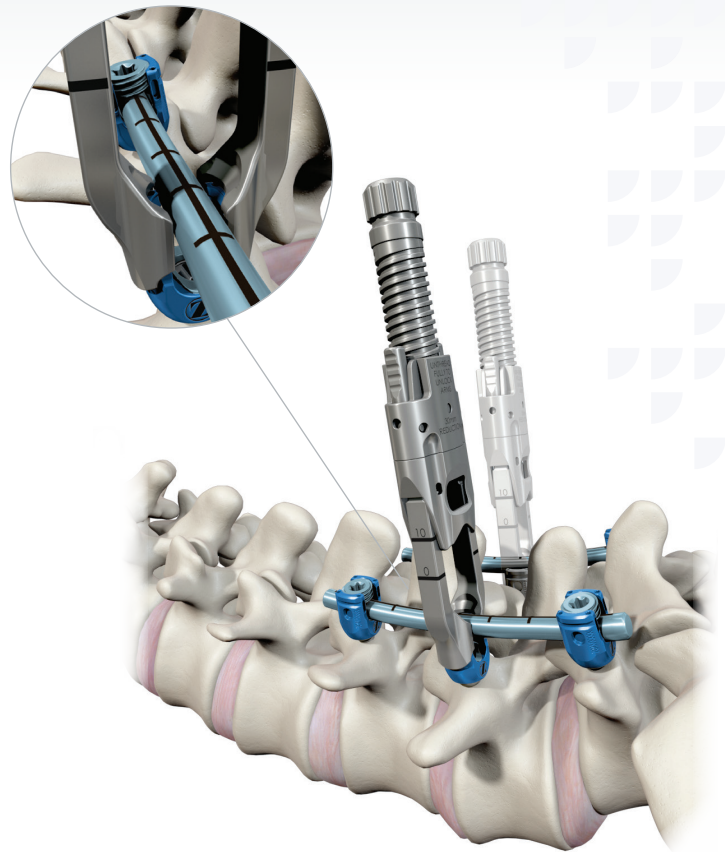
The rod capture window allows straightforward screw engagement while accommodating significant medial or lateral rod offset. The short rocket threaded reducer allows for 30 mm of total reduction and 15 mm of medial-lateral rod translation (Figure 69).

#### **Rocket™ Threaded Reducer features and benefits:**

- The rocket threaded reducer provides gradual tactile rod reduction.
- The rocket threaded reducer features spring loaded tips that provide tactile feedback and secure engagement with screw and hook implants from the Vital Spinal Fixation System.
- The rocket threaded reducer allows for 15 mm of medial-lateral rod translation and a self-centering reduction anvil.
- The rocket threaded reducer's self-centering rod anvil features infinite adjustability for controlled and sequential reduction.



**Figure 70**  
Attaching rocket reducer to screw

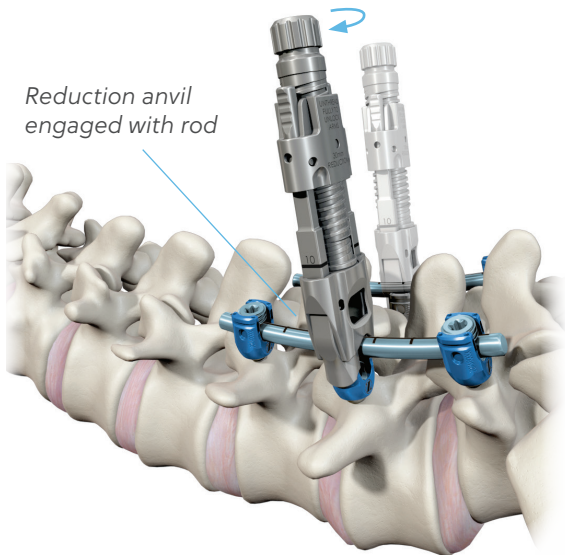


**Figure 71**  
Rocket attached to screw

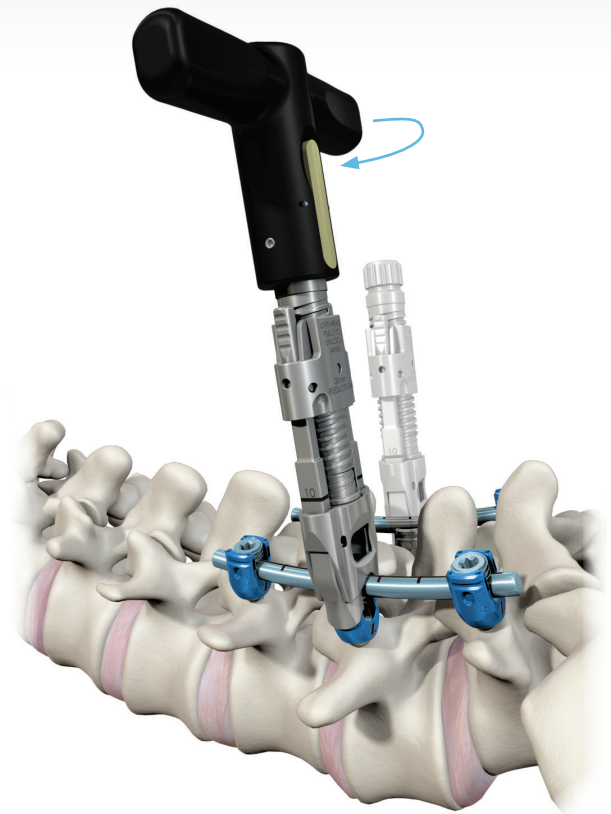
## Rocket Threaded Reducer Steps

- To properly attach and remove the rocket reducer, ensure the reducer is completely unthreaded, where there is no gap between the reduction anvil and reduction block. Grasp the rocket reducer by the reduction block or the threaded reduction barrel.
- To attach the Rocket reducer to the vital screw tulip, depress both of the finger tabs of the spring-loaded arms and position the arms of the rocket so that they mate with the side features of the screw tulip (Figure 70).
- To provisionally secure the rocket reducer to the screw tulip head, grasp the positive stop area at the proximal end of the rocket reducer's threaded reduction barrel and rotate clockwise—1/2 turn to ensure full engagement of the rocket (Figure 71).

## Reduction Instrumentation (continued)



**Figure 72**  
Provisionally reducing rocket anvil to meet rod

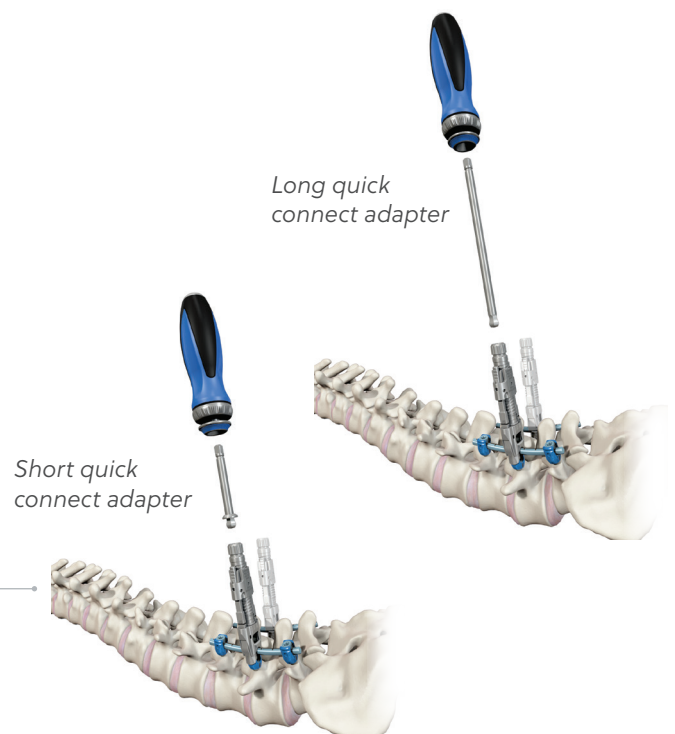


**Figure 73**  
Rod persuasion using rocket reducer and T-handle

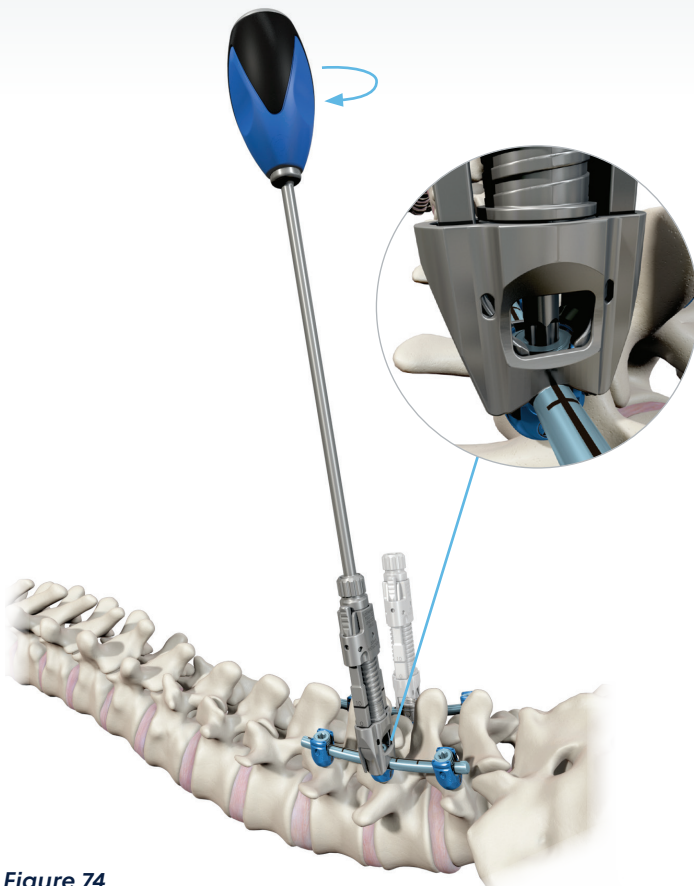
## Rocket Threaded Reducer Steps (continued)

- Once the desired number of rocket reducers are attached, manually rotate each rocket reducer's threaded reduction barrel clockwise until the reduction anvil engages the rod (Figure 72).
- Once all rocket reducers are properly attached, aligned, and their reduction anvils are contacting the rod, utilize the black reduction T-handle to sequentially reduce the screws to the rod by turning the threaded reduction barrel clockwise (Figure 73).
- The rod is fully reduced when the positive stop on the rocket reducer is reached, and can be confirmed by the laser markings on the spring loaded arms if visible.

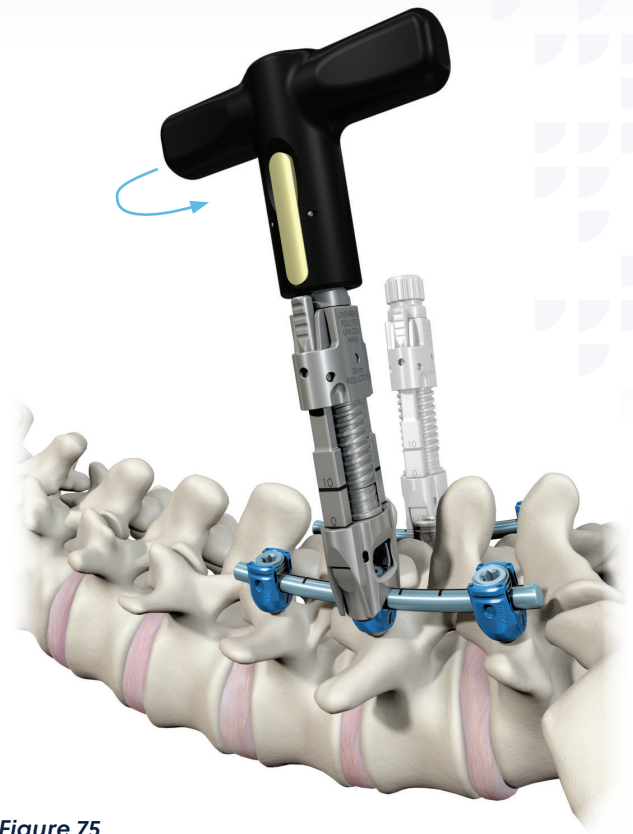
**Note:** The short and long quick connect adapters (attached to preferred handle) can be utilized to reduce the screws to the rod.





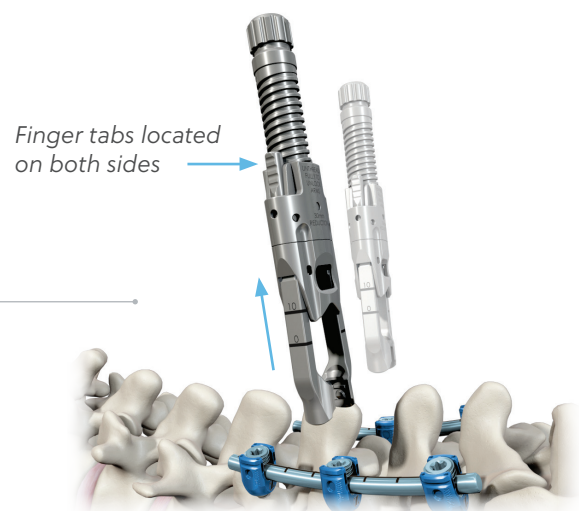


**Figure 74**  
 Closure top introduction and provisional tightening through rocket reducer

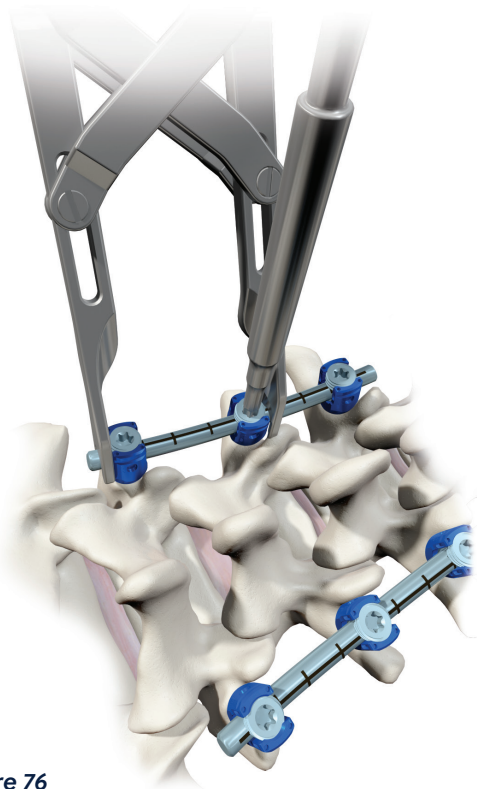


**Figure 75**  
 Removing rocket reducer

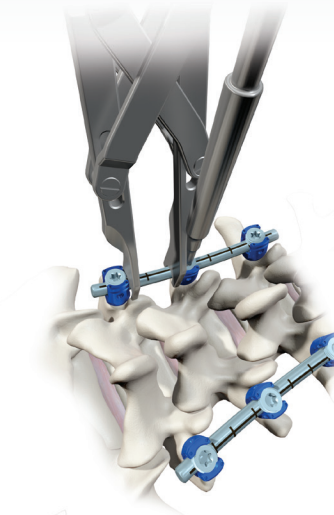
- Once the rod is fully seated in each screw head, use the T27 provisional driver to introduce the closure tops into the screw heads.
- Turn the T27 provisional driver clockwise until the closure top is fully seated in the screw tulip and holds the rod in place. Do not final tighten (Figure 74).
- To remove the rocket reducer, utilize the black reduction T-handle to turn the threaded reduction barrel counterclockwise until the anvil and reduction block of the rocket meet (Figure 75).
- Once the rocket reducer is completely unthreaded, depress the finger tabs of the spring loaded arms and remove the rocket. Repeat until all rockets have been removed.



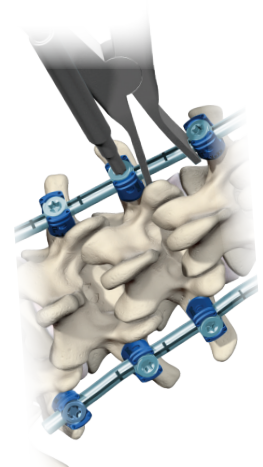
## Compression and Distraction



**Figure 76**  
Compression



**Figure 77**  
Distraction using  
parallel distractor



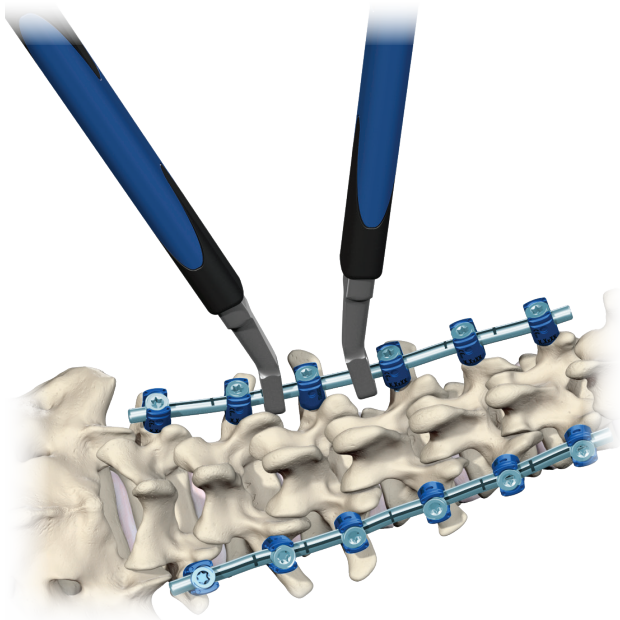
**Figure 78**  
Distraction using  
single-pivot distractor

### Compression/Distraction

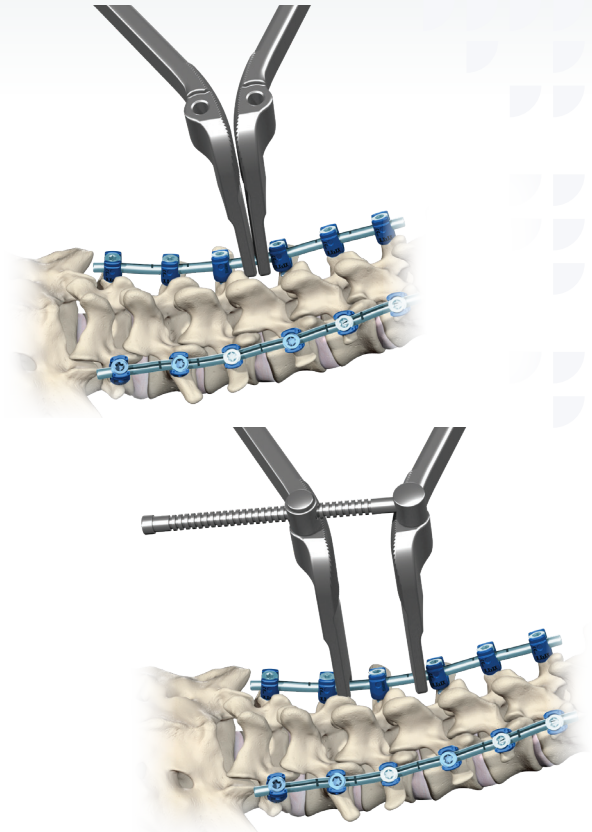
- To compress two screws simultaneously, place the compressor against the screws' tulip heads and squeeze the handle. Compression can also be performed sequentially by provisionally locking one screw using the T27 provisional closure top driver and compressing off the provisionally locked screw. When the compression maneuver is complete, provisionally lock the compressed screw and release the compressor.
- To distract two screws simultaneously, place the distractor against the screws' tulip heads and squeeze the handle. Distraction can also be performed sequentially by provisionally locking one screw using the closure top starter and distracting off the provisionally locked screw. When the distraction maneuver is complete, provisionally lock the distracted screw and release the distractor.
- The distraction or compression device will maintain the position of the vertebra until the closure top is tightened with the provisional driver, thus securing the rod.  
**Note:** *The rod gripper may act as an intermediary point when compressing/distracting.*

#### Specific compressors and distractors are available to facilitate various anatomical and pathological considerations.

- Single-level parallel compressor: 15 mm to 54 mm
- Multi-level parallel compressor: 42 mm to 86 mm (Figure 76)
- Single-level parallel distractor: 6 mm to 41 mm (Figure 77)
- Single-level pivot distractor: 5 mm to 24 mm (Figure 78)
- Multi-level parallel distractor: 39.1 mm to 74.9 mm



**Figure 79**  
Sagittal bending irons



**Figure 80**  
Coronal bending irons with and without bender fulcrum

## In Situ Bending

- *In situ* contouring may be performed with sagittal and/or coronal benders prior to final tightening. In general, the sagittal benders are primarily used to improve or adjust kyphosis and lordosis, while the coronal benders are used to reduce coronal plane deformity (Figure 79).
- The coronal benders may be used in conjunction with the coronal bender fulcrum, in order to bend the rod over a larger arc radius, rather than bend at a focal point on the rod (Figure 80).
  - Note:** Provisionally tighten the implants using the closure top starter before attempting to bend *in situ*.
  - Note:** Choose the appropriate diameter sagittal bender based on the diameter of rod being used.

## Final Tightening



**Figure 81**  
Final tightening

### Final Tightening

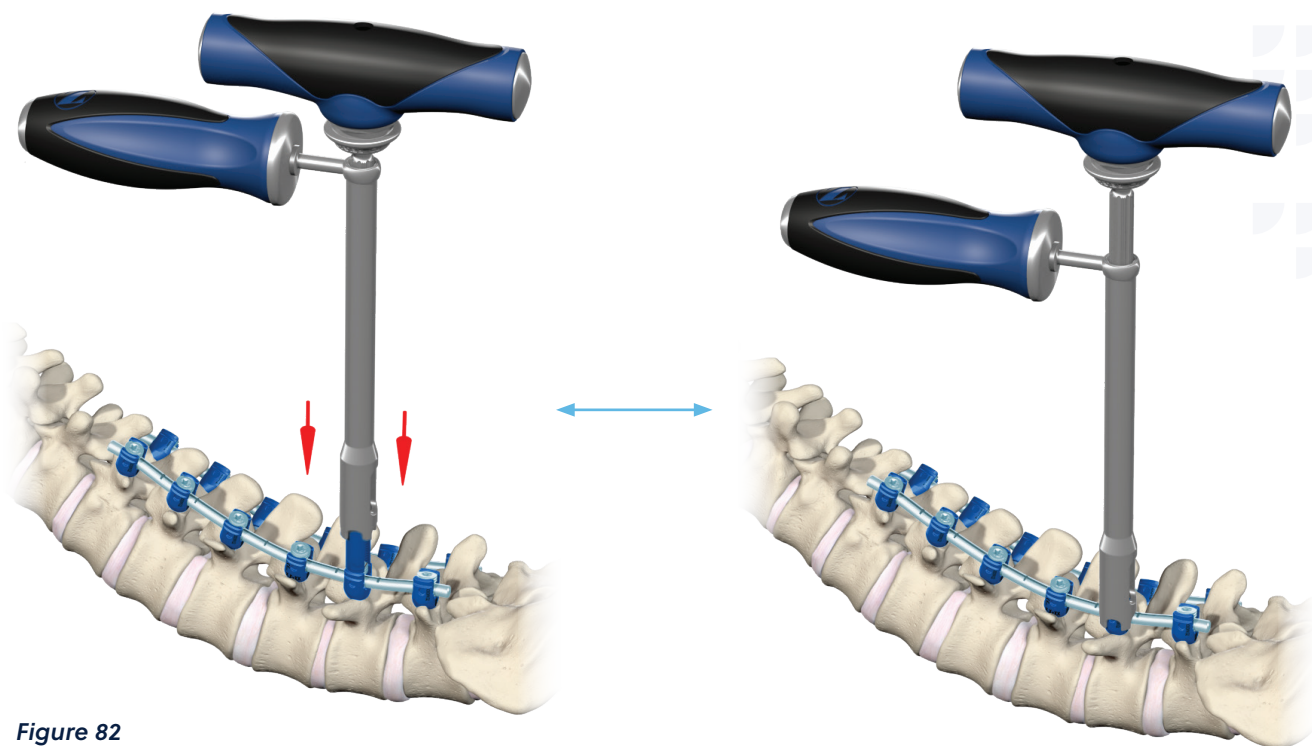
- Once rod reduction, compression/distraction, and manipulation maneuvers have been completed, all of the closure tops must be final tightened. If monoaxial screws are used at the proximal or distal end of a construct, it is highly recommended that reduction instruments are used to ensure closure top and rod are fully seated prior to final locking.
- When using the standard closure top, connect the final driver to the 90 in-lb (10.17 Nm) torque-limiting handle. Pass the final driver through the counter-torque and insert it into the hexalobe driver interface on the closure top. While applying appropriate counter-torque, turn the final closure top driver clockwise until the 90 in-lb (10.17 Nm) torque-limiting handle clicks over a minimum of two times (Figure 81).

**Note:** Visually confirm the final driver tip full engagement in the closure top before sliding the counter-torque over the screw head.

**Note:** Always use the 90 in-lb (10.17 Nm) torque-limiting handle for final tightening closure tops.

- When using the shear-off closure top, use the shear-off final driver. Pass the shear-off final driver through the counter-torque and engage the hex interface on the shear-off closure top. While applying appropriate counter-torque, turn the final shear-off driver clockwise until the hex drive feature on the shear-off closure top breaks off.

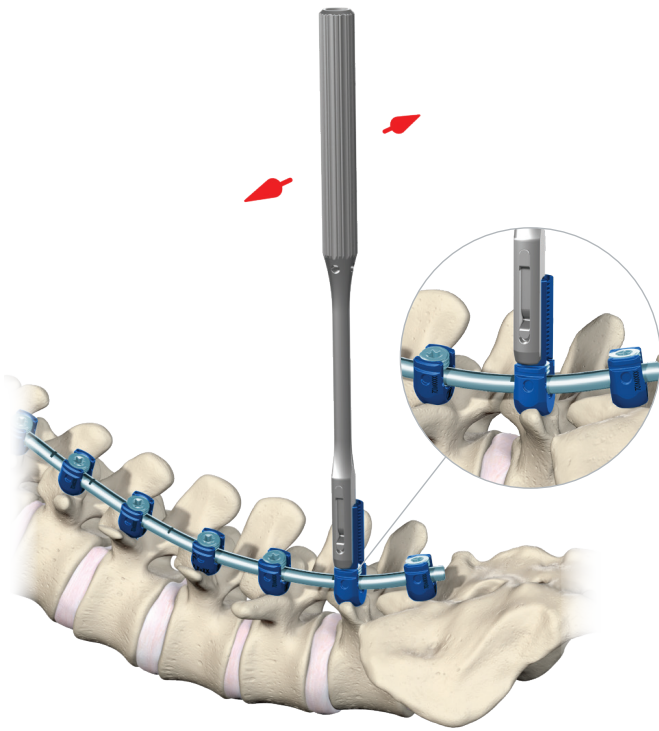
**Note:** The shear-off closure top will snap off at 90 in-lb (10.17 Nm).



**Figure 82**  
Final tightening with reduction screws

- To empty the snapped off portion of the closure top, turn the shear-off final driver upside down and depress the release button where the shaft of the instrument meets the handle. A rod may be used to push out any caps that remain in the driver. The snapped off portions of the closure tops should only be removed from the driver over the back table and away from the sterile field around the patient. Always collect these break-off portions of the closure tops until after the surgical team's count has been performed. Only after the count should the break-offs be disposed of.
- The standard counter-torque handle works with all Vital screws. When ready to final tighten the closure tops used in conjunction with reduction screws, connect the final driver to the torque-limiting handle, pass the final driver through the counter-torque and engage the T27 final driver tip into the closure top.
- Slide the counter-torque over the reduction screw head and final tighten the closure top using the 90 in-lb (10.17 Nm) torque-limiting handle. Turn the final closure top driver clockwise until the 90 in-lb (10.17 Nm) torque-limiting handle clicks a minimum of two times. Only after final tightening should the reduction screw tabs be removed (Figure 82).

## Final Tightening (continued)

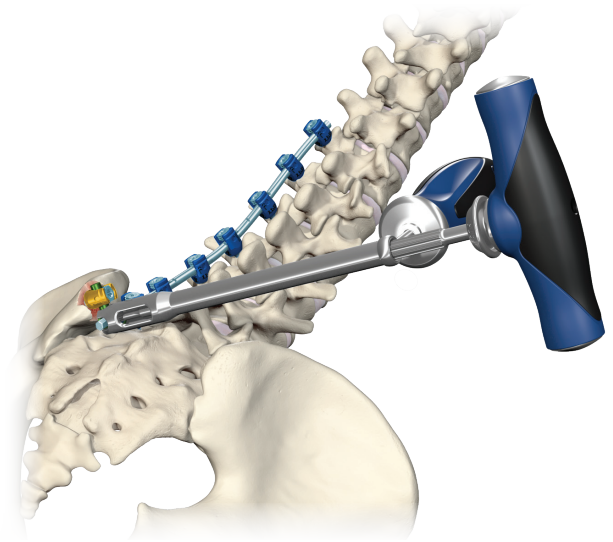


**Figure 83**  
Removing reduction screw's extended tabs

### Tab Removal

- Use the reduction tab breaker to remove the reduction screw tabs. Bending the tab medial to lateral will release it from screw head. Repeat for the second tab (Figure 83).

**Note:** Reduction screw tabs may have rough edges after removal, which should be handled with care. Reduction screws with the tabs broken off may not be compatible with the tower, rocket, or single action reducers. In this case rod reduction may be achieved with the rod pusher, rod manipulator, or rod rocker.



**Figure 84**  
Final tightening lateral offset connector

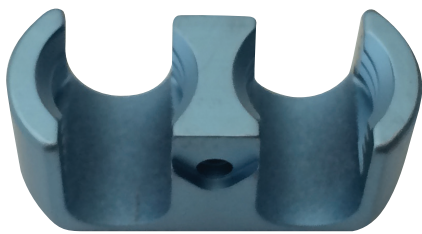
### Lateral Offset Connector Final Locking

- Connect the final driver to the torque-limiting handle. Pass the final driver through the counter-torque and engage the final driver tip into the closure top. Slide the counter-torque over the lateral connector head and final tighten the closure top using the 90 in-lb (10.17 Nm) torque-limiting handle. Turn the final closure top driver clockwise until the 90 in-lb torque-limiting handle clicks a minimum of two times (Figure 84). Repeat for the closure top on the iliac screw.

**Note:** The lateral offset connector should be final tightened before final locking the closure top on the iliac screw.

- The iliac screws and offset connectors provide additional stabilization for an S1 screw. It is recommended that iliac screws are used in conjunction with S1 screw fixation.

## Connector Options



**Figure 85**  
Lateral channel rod connector



**Figure 86**  
Connectors with closure tops using T20 interface

### Rod-to Rod-Connectors

Should a surgeon need to link two separate rods together, the Vital System offers a variety of different style rod-to-rod connectors, which connect to 3.5 mm, 5.5 mm and 6.0 mm rods. Depending on the style of connector that is being used, a closure top or connector set screw will be used in conjunction with the appropriate final driver, torque-limiting handle and counter-torque to final lock the rod-to-rod connectors.

The lateral channel rod connector (Figure 85) accepts either a standard or break-off closure top that are provisionally tightened with the T27 provisional driver and are final tightened with either the T27 Final driver and the 90 in-lb (10.17 Nm) torque-limiting handle; or the shear-off final driver.

The other connectors include connector set screws that accept the T20 driver and are finally tightened using the T20 final driver and 50 in-lb (5.65 Nm) torque-limiting handle (Figure 86).

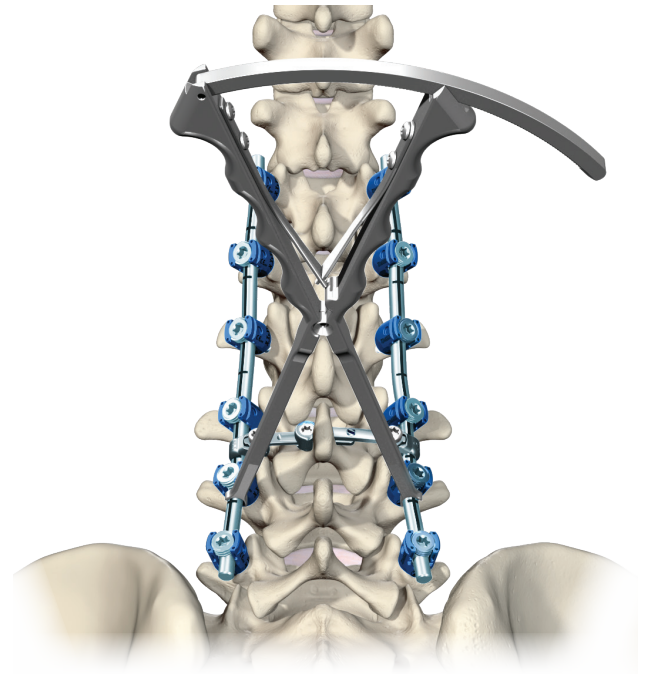
**Note:** The rod-to-rod connector forceps can be used to assist with placing any of the connectors onto the rods.

**Note:** The counter-torque should be used adjacent to the selected connector along the rod to provide adequate counter-torque when final tightening.

## Connector Options (continued)



**Figure 87**  
Transverse connector



**Figure 88**  
Transverse connector calipers

### Transverse Connectors

- A transverse connector may be used at the surgeon's discretion if additional construct stability is desired. The Vital system offers both adjustable and fixed transverse connectors. Ensure the appropriate size of transverse connector is selected to match the rod diameter (Figure 87).

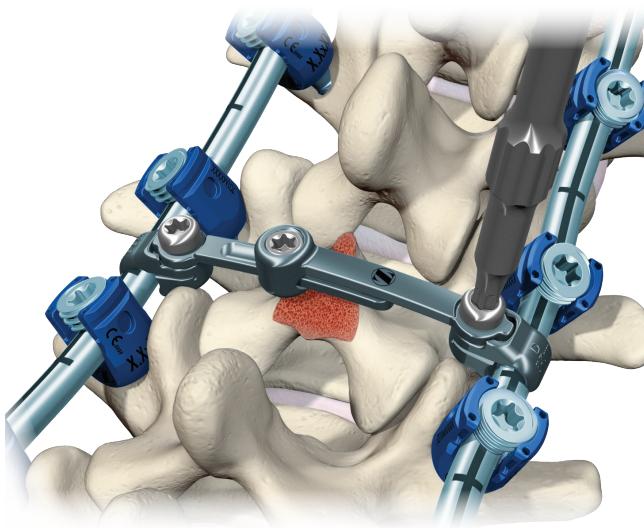
**Note:** With 5.5 mm rods use the light blue transverse connectors and with 6 mm rods use the green transverse connectors.

### Transverse Connector Caliper

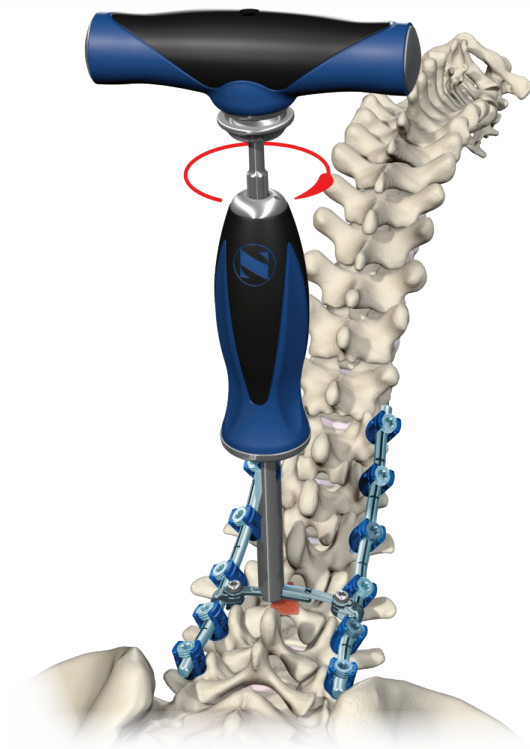
- Use the transverse connector caliper to determine the appropriate size transverse connector. Place the ends of the caliper directly onto each rod at the desired location for connector placement (Figure 88). The corresponding measurement reading provides the suggested length of the connector. The transverse connector caliper has dedicated markings that correlate to both the appropriate length implant and the location in the caddy.

**Note:** The caliper markings A–E refer to adjustable transverse connectors and 1–6 refer to fixed transverse connectors.





**Figure 89**  
Adjustable transverse connector



**Figure 90**  
Final tightening of transverse connector

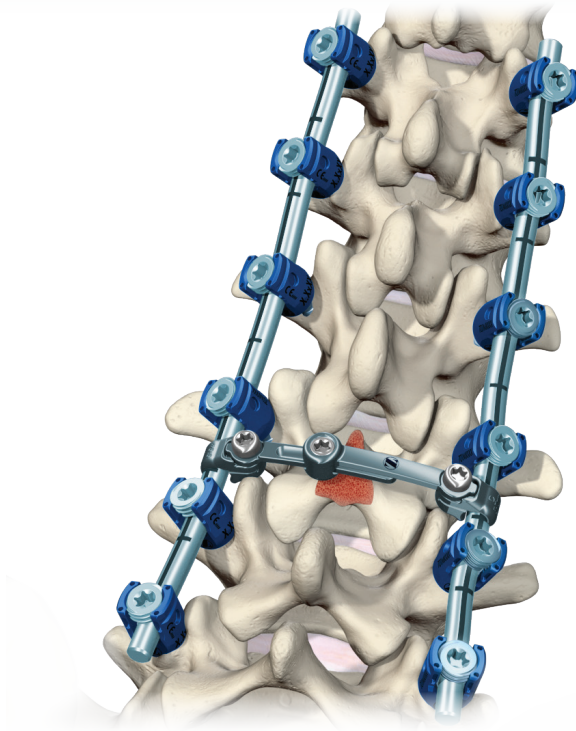
## Transverse Connector Placement

- When using an adjustable transverse connector, first confirm that the center set screw is loose to allow for free range of motion prior to placing the adjustable transverse connector onto the rod construct. Fixate each end of the connector to each rod by pushing anteriorly on the set screw using the set screw starter (Figure 89). Final lock each end of the transverse connector to the rod using the T20 final driver, 50 in-lb torque-limiting handle and transverse connector counter-torque. Turn the T20 final driver clockwise until the 50 in-lb (5.65 Nm) torque-limiting handle clicks over a minimum of two times.
- Final lock the middle transverse connector set screw last using the same T20 final driver and torque-limiting handle. Turn the T20 final driver clockwise until the 50 in-lb (5.65 Nm) torque-limiting handle clicks over a minimum of two times (Figure 90).

**Note:** Make sure the same size transverse connector and rod (5.5 mm or 6.0 mm) are used together.

**Note:** The transverse connector counter-torque has a "Medial" marking indicating the orientation of the instrument when locking the set screws on the rod.

## Final Construct



**Figure 91**  
Final construct

## Final Construct

---

- Re-check all connections of the final construct. Intraoperative radiographic image of the final construct should be taken to confirm the desired construct is achieved prior to wound closure (Figure 91).

## Removal or Revision



**Figure 92**  
Closure top removal



**Figure 93**  
Pedicle screw removal  
with head height adjuster

**Figure 94**  
Pedicle screw removal with the vital standard screwdriver

### Remove Closure Tops (if necessary)

- Remove the closure tops by turning the closure top counterclockwise using the T27 final closure top driver. The counter-torque may be used to provide additional leverage to loosen the closure top (Figure 92). When all closure tops have been removed, the rod may be removed manually or by using the rod holder.

**Note:** If the closure top interface is damaged, the easy out removal driver can be used to loosen the closure top.

### Remove Implanted Screw

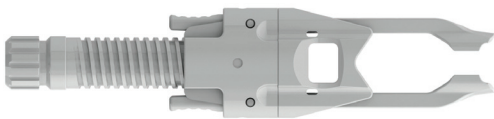
The Vital head height adjuster or the Vital screwdriver can be used to remove an implanted screw.

- To remove a screw using the head height adjuster, align the head height adjuster coaxially with the shank of the screw and engage the adjuster's male hexalobe with the female hexalobe of the screw shank. Turn the head height adjuster counterclockwise to back out an implanted screw (Figure 93).
- To remove a screw using the vital standard screwdriver, align the driver coaxially with the shank of the screw and engage the driver's male hexalobe with the female hexalobe of the screw. Turn the outer driver sleeve clockwise to fully engage the screw head. Lock the driver sleeve by pushing on the secondary lock and sliding the collar downwards. Turn the driver counterclockwise to remove an implanted screw (Figure 94).

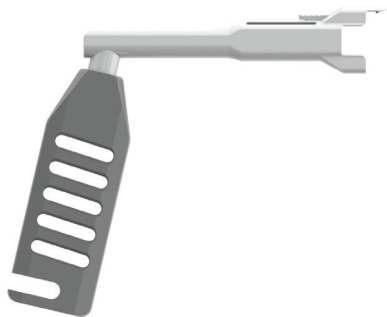
## Vital Deformity Derotation and Instrumentation

The Vital Deformity System includes an efficient combination of rod reduction and vertebral body derotation instruments. It embodies the next evolution of instrumentation from ZimVie focused on of instrumentation focused on addressing complex spinal deformity. The foundation of the system is built upon the Rocket™ threaded reducer, DeRoduction™ handles, and derotation handles. Traditionally, three-dimensional deformity correction techniques have required rod reduction, followed by vertebral body derotation. The Rocket threaded reducer and DeRoduction handles now provide the surgeon with the intra-operative flexibility to choose the sequence of vertebral body derotation and rod reduction independently. No longer is the surgeon forced to reduce the screw to the rod, in order to then derotate the spinal deformity.

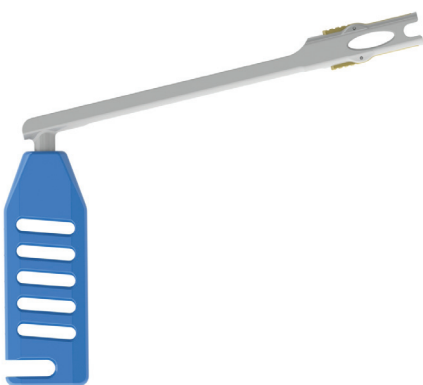
### Component Overview



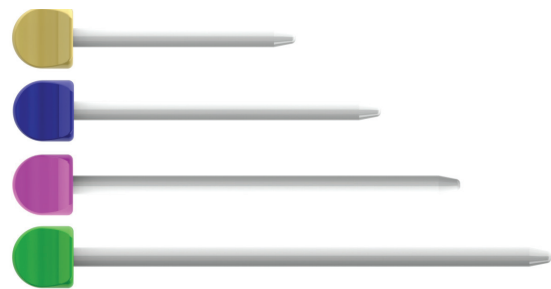
<b>Rocket Threaded Rod Reducer</b>	PART NUMBER
	730M0024



<b>DeRoduction Handle</b>	PART NUMBER
	14-500204



<b>Derotation Handle</b>	PART NUMBER
	730M0000



Linkage Rods	PART NUMBER
Size 2-3	14-501003
Size 3-4	14-501004
Size 4-5	14-501005
Size 5-6	730M0043



<b>25 cm Alignment Rod</b>	PART NUMBER
	14-501006



<b>38 cm Alignment Rod</b>	PART NUMBER
	14-501007



<b>30 cm Comb</b>	PART NUMBER
	14-501008



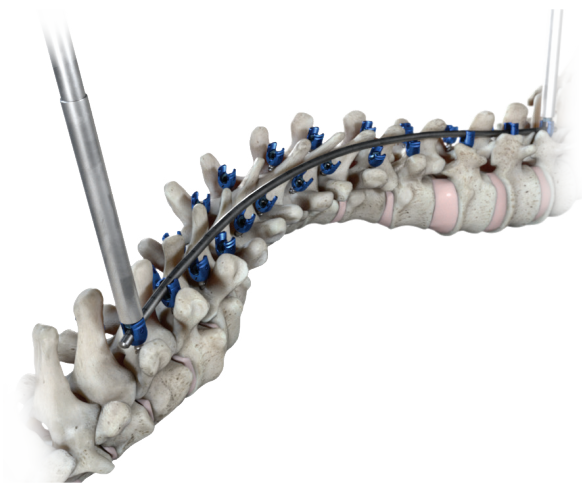
<b>36 cm Comb</b>	PART NUMBER
	14-501009

The Vital Deformity System is designed to provide versatile and efficient instrumentation that is specifically designed for complex spinal deformity correction. By truly providing deformity correction in all three anatomical planes, the Vital Deformity derotation instrumentation represents the next evolution in deformity correction from ZimVie. The specialized deformity instrumentation allows the surgeon to adopt and merge numerous combinations of traditional derotation techniques.

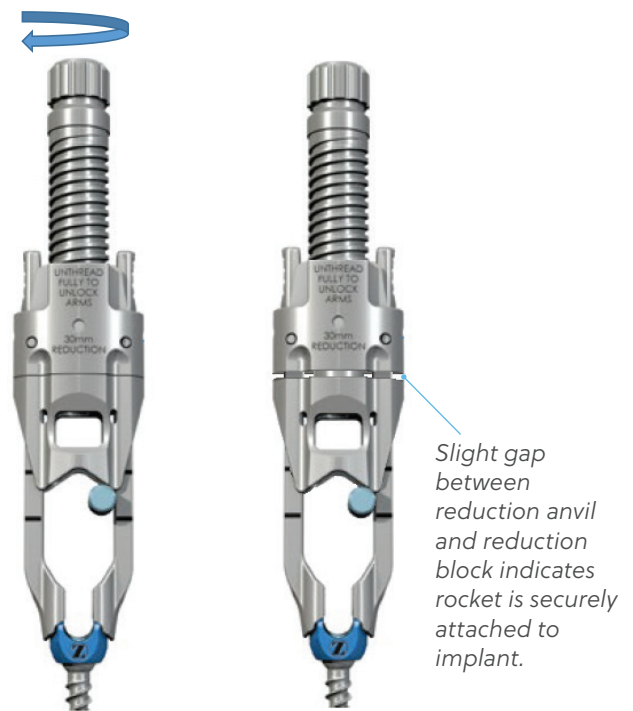
**Notes on Implant and Derotation Instrumentation Placement:**

Common areas where derotation can be of benefit are the apical and end vertebrae. Vertebral derotation is most effective when opposing axial plane corrective forces are counter-rotated against each other—for example a right thoracic curve being counter-rotated against a left thoracolumbar curve.

In order to safely and effectively correct axially rotated segments of the spine; it is important that there are appropriate and sufficient fixation points against which to derotate. For this reason, the Rocket threaded reducer and derotation handles provided in the system are designed to attach to any fixation implant along a Vital construct. By doing so, this instrumentation is designed to maximize axial corrective forces and load-shares by reducing the stress applied to individual pedicles.



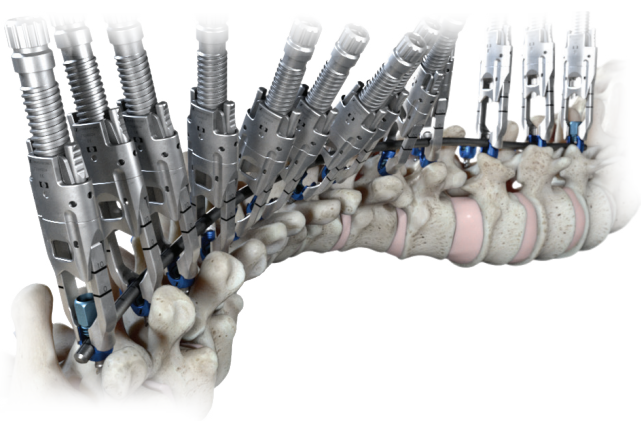
**Figure 95**  
Provisionally secure rod into proximal and distal screw tulips



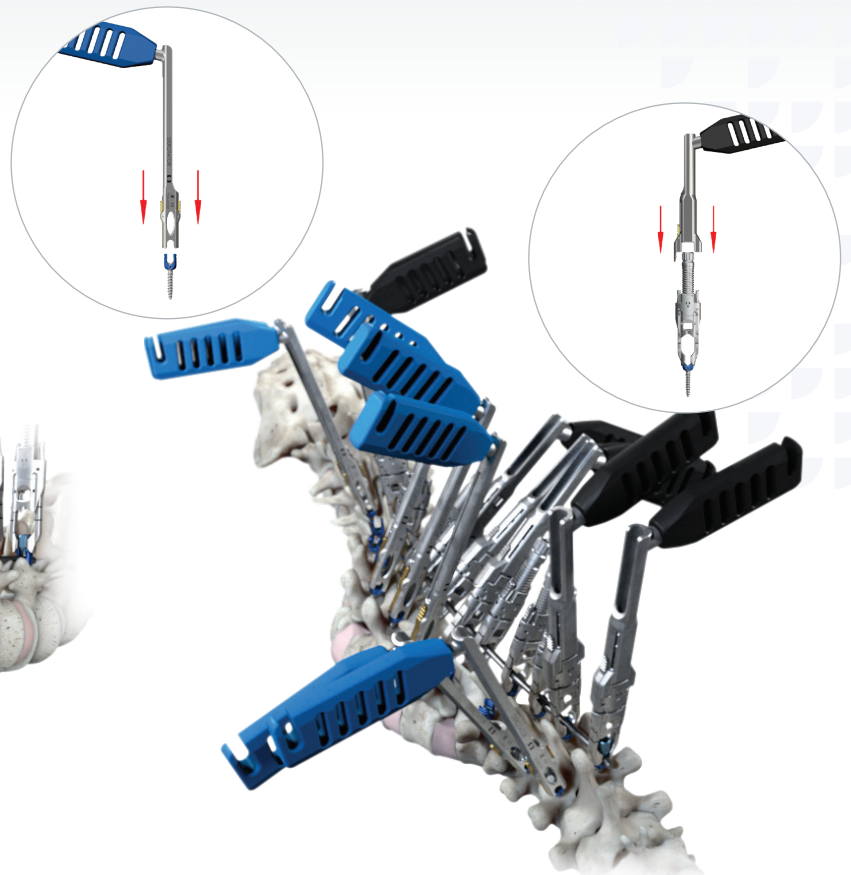
**Figure 96**  
Placement of rocket and securing it to implant

### Single Rod En Bloc Derotation

- After placing screw and hook implants at the desired vertebral levels, use one of the head alignment tools to properly align the screw heads that are ipsilateral to the concavity of the patient's thoracic curve. Since the majority of adolescent idiopathic scoliosis patients will present with a right thoracic curve, most often the first rod is introduced to the patient's left side.
- Using the rod template, measure the length to which the rod will need to span. Select the appropriate length rod and cut to the length previously measured. Using the French rod bender, bend the rod to the desired contour.
- Place the cephalad and caudal ends of the rod into the saddles of the most proximal and distal screws within the construct. Provisionally secure the rod into place using at least one closure top at either the proximal or distal pedicle screw—both, if at all possible (Figure 95).
- Begin placing Rocket threaded reducers along the rod at each pedicle screw.
  - Note:** Some surgeons may find that first using the planar tool to remove soft and bony tissue around the thoracic pedicle screws will make securing Rockets at these levels an easier task.
- To properly attach and remove the rocket reducer, ensure the reducer is completely unthreaded, where there is no gap between the reduction anvil and reduction block.
- To attach the Rocket reducer to the vital screw tulip, depress both of the finger tabs of the spring-loaded arms and position the arms of the rocket so that they mate with the side features of the screw tulip.
- To provisionally secure the rocket to the screw head, grasp the positive stop area at the proximal end of the rocket's threaded barrel and rotate clockwise – ½ turn to ensure full engagement of the rocket (Figure 96).



**Figure 97**  
Rockets used to capture rod



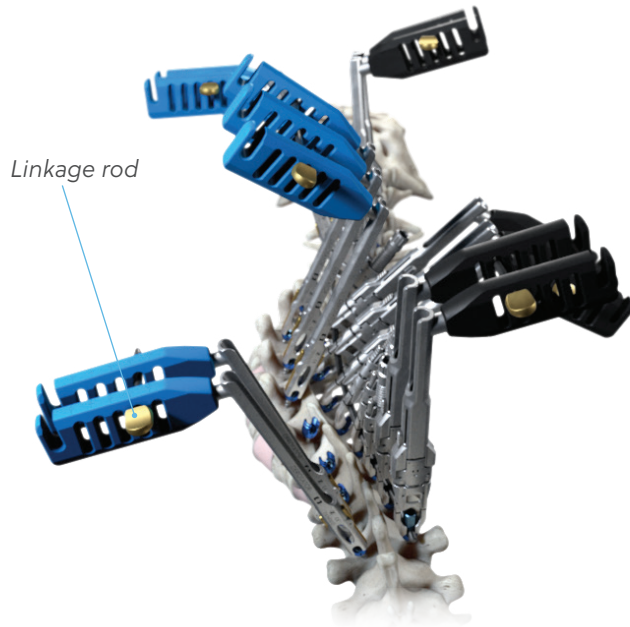
**Figure 98**  
Deroduction handles and derotation handles attached along construct

- Continue this process at each desired implant along that side of the construct. With larger curves, in order to facilitate rocket placement at apical vertebrae, it is suggested that the surgeon begin by first placing Rocket threaded reducers at the periphery of the construct and work towards those apical vertebrae (Figure 97).

**Note:** If the cleats of the rockets cannot reach the apical screws when the arms are placed around the rod, the rod may be temporarily rotated out of the ideal sagittal alignment in order for the rockets to capture the rod.

- Once the rockets are in place, attach the DeRoduction handles to the rockets intended for en bloc or direct vertebral rotation. On the contralateral aspect of the construct, place derotation handles on implants opposite from the pedicles where rockets and deroduction handles are in place (Figure 98). Again, vertebral derotation is most effective when opposing axial plane corrective forces are counter-rotated against each other—for example a right thoracic curve being counter-rotated against a left thoracolumbarcurve.

## Vital Deformity Derotation and Instrumentation (*continued*)



**Figure 99**  
*Linkage rods added to handle clusters*



**Figure 100**  
*Combs affixed between handle clusters by linkage rods*

### Single Rod En Bloc Derotation (*continued*)

- Linkage rods are inserted through the handle slots of grouped derotation and deroduction handles (Figure 99).
- Attach the comb to the linkage rods, thus linking contralateral handles (Figure 100).





**Figure 101**  
 Derotate spine by rotating apices against each other, or proximal and distal blocs against apex

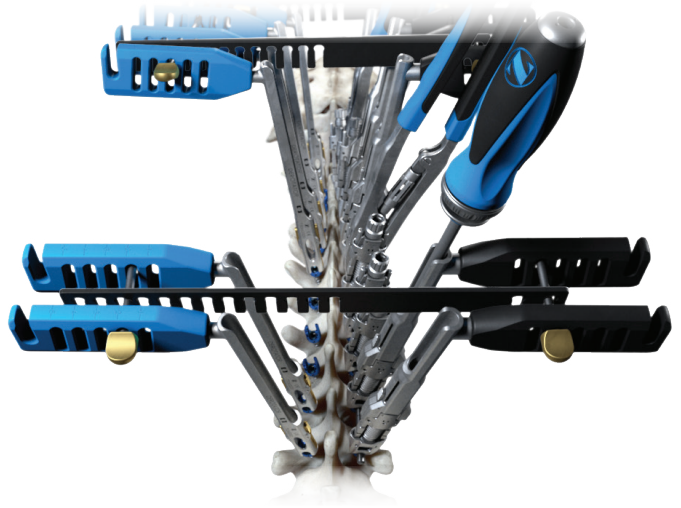


**Figure 102**  
 En bloc derotation with blocs aligned

- Derotate the spine by manipulating the linked handles. The clusters should be rotated counter to one another. For example, when addressing a double major deformity featuring a right thoracic curve, the thoracic apical cluster should be rotated to the patient's right, while the corresponding lumbar apical cluster should be rotated in the opposite direction, to the patient's left. If the surgeon is addressing a single structural curve with a compensatory adjacent curve, the apical cluster may be counter-torqued against instrument clusters adjacent at the proximal and distal segments of the construct (Figure 101).
- Once the handles in each bloc are aligned, the surgeon may choose to use the linkage clusters in order to hold the handles in place and prevent the handle clusters from returning to their original positions. Otherwise the surgeon may choose to have one of the surgical staff hold the clusters in place (Figure 102).



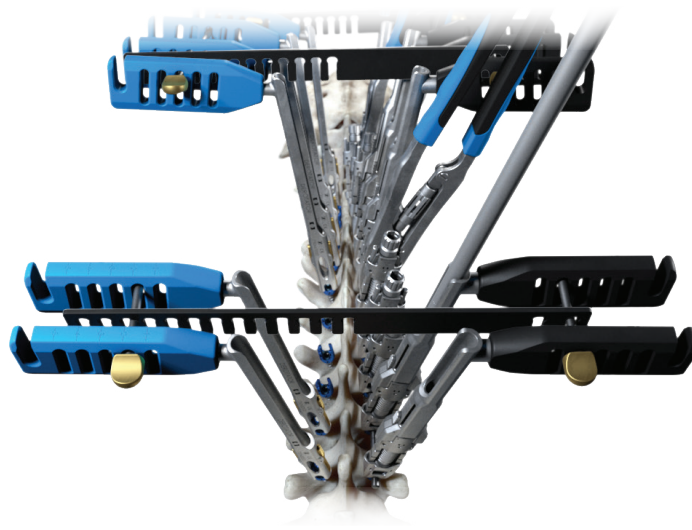
**Figure 103**  
*Global derotation using rod grippers*



**Figure 104**  
*Rocket reduction using QC adaptor and handle*

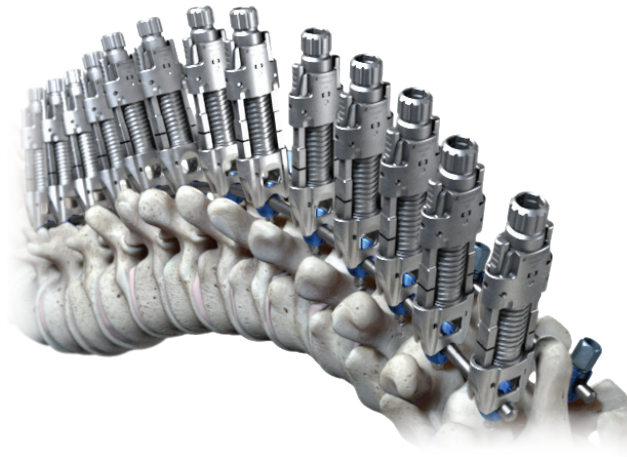
### Single Rod En Bloc Derotation (*continued*)

- The surgeon should then use rod grippers, or vise grips, to rotate the rod into the proper sagittal alignment (Figure 103).
- While maintaining the ideal sagittal alignment of the rods with the rod grippers, or vise grips, use the long, ball-nosed hex driver and driver handle of any type, to sequentially reduce each rocket and persuade the spine to the rod. Once the rockets are fully reduced and the rod is seated in each screw tulip (Figure 104).



**Figure 105**  
*Provisional placement and tightening of closure tops  
 along construct*

- Place closure tops along the construct at each screw, using one of the T27 provisional drivers and inserting them through the cannulas of the rockets and DeRoduction handles (Figure 105).
- Once the rod is provisionally secured, remove the derotation handles, deroducers, and rockets.
- At this point, the surgeon should determine if any additional in situ bending is necessary. If so, use the sagittal and coronal benders to adjust the rod contour.
- Using the rod template, determine the length necessary for the second rod.
- Use the French bender to bend the second rod to the desired contour. Just as before, provisionally place the rod into the screw tulips at the proximal and distal ends of the construct and secure the rod into place using closure tops at one or both of the peripheral screws.
- Use one of the head alignment tools to properly align the open screw heads that are contralateral to the first rod.
- Using the rod template, measure the length to which the rod will need to span. Select the appropriate length rod and cut to the length previously measured. Using the French rod bender, bend the rod to the desired contour.
- Place the cephalad and caudal ends of the second rod into the open saddles of the most proximal and distal screws within the construct.
- Provisionally secure the rod into place using at least one closure top at either the proximal or distal pedicle screw—both, if at all possible.



**Figure 106**  
*Securing and persuading second rod with rocket reducers*

### Single Rod En Bloc Derotation *(continued)*

---

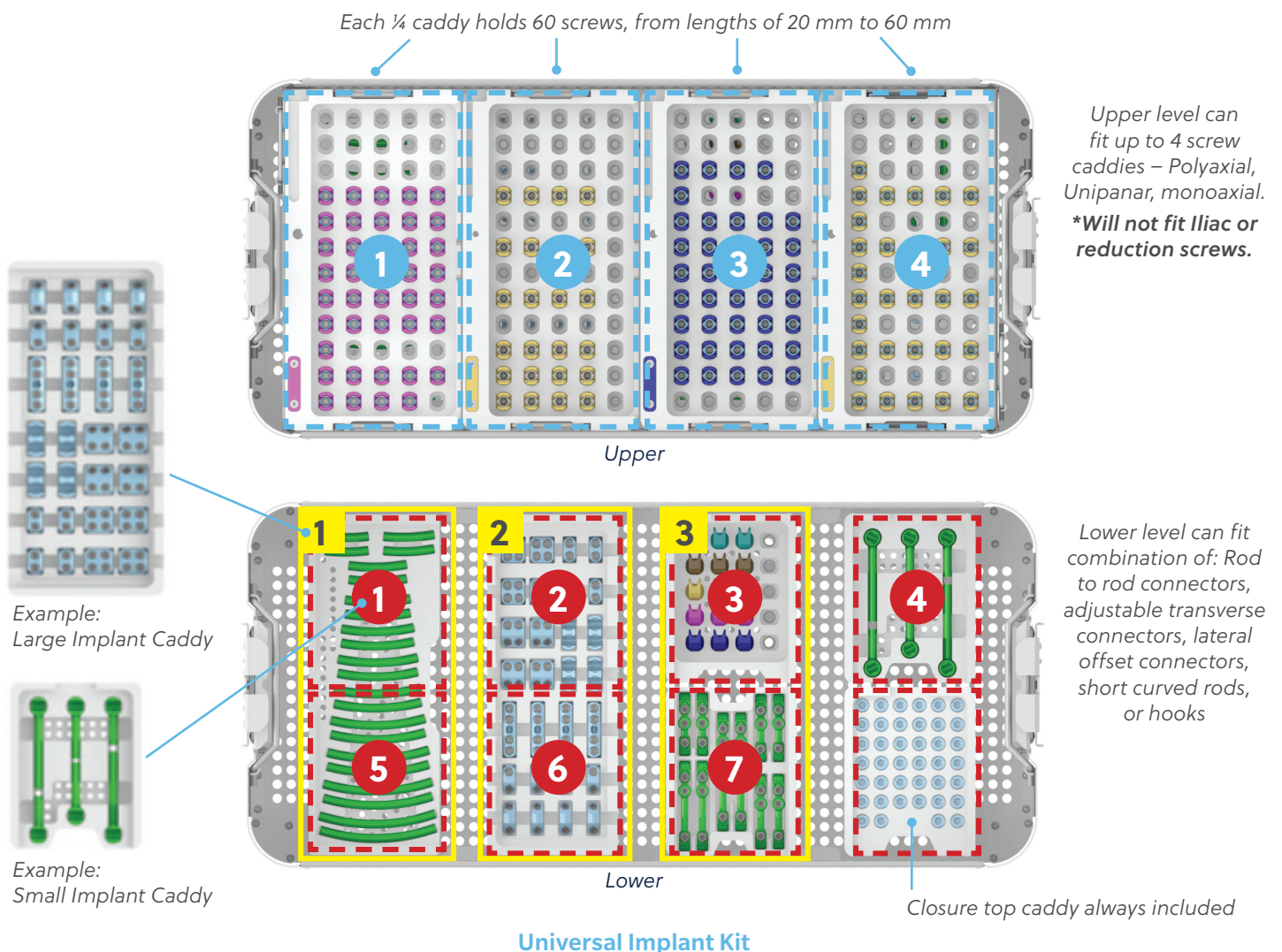
- Begin placing rocket threaded reducers along the second rod at each pedicle screw.
- Sequentially reduce each rocket until the spine is persuaded to the rod and the rod is seated in each screw or hook tulip (Figure 106). Using one of the T27 provisional drivers, introduce closure tops to each implant tulip and provisionally tighten. Once the rod is secured in each implant tulip, remove the rockets.
- At this point, the surgeon may desire to make slight segmental adjustments to the construct by using compressors, and/or distractors. Once these adjustments are made, the construct must be finalized by either final tightening the standard closure tops, or breaking off the tops of the shear-off closure tops.

## Kit Ordering Overview

The Vital Spinal Fixation System is designed to deliver value to the entire surgical team, not simply the surgeon. The kits and implant caddies that make up the system are optimized to provide greater intraoperative and perioperative efficiency and adaptability, while minimizing shelf space and back table footprint.

- The core of the system are the Vital Instrument Kit and Vital Implant Kit. There are additional instrument kits intended to accommodate more complex procedures.
- Each Vital Implant Caddy is to be ordered independently of an outer kit. These implant caddies may be sterilized independently, or placed into one of 6 implant kits

- 1 Universal Implant Kit
- 2 Reduction Kit
- 3 Iliac Implant and Instrument Kit
- 4 Complex Rod Kit
- 5 Hook Kit
- 6 Cannulated Implant and Instrument Kit

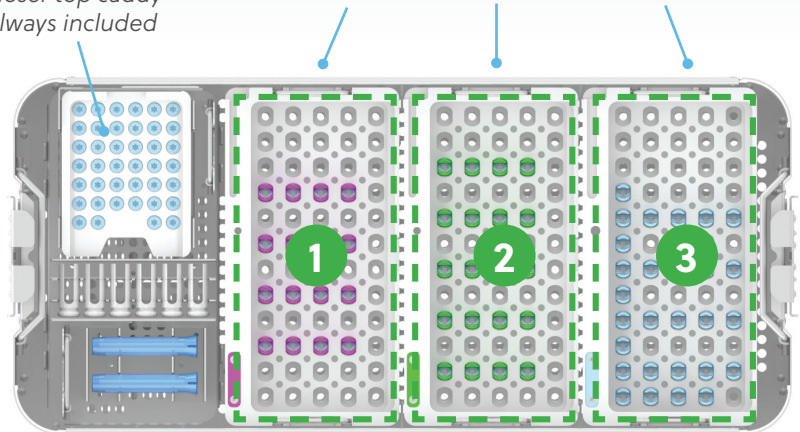


## Kit Ordering Overview (continued)

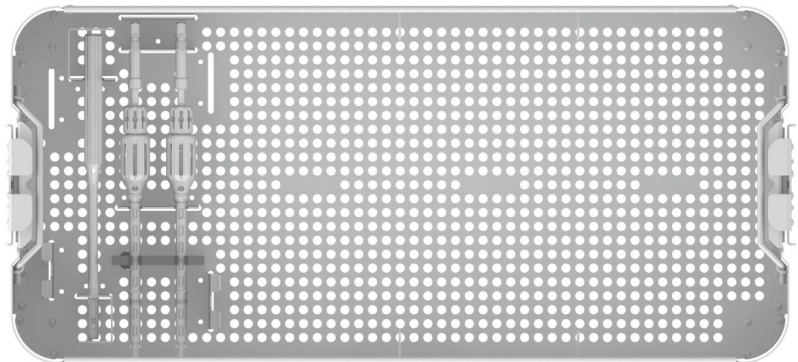
- The Universal Implant Kit is designed to accept 4 standard pedicle screw caddies—polyaxial, uniplanar, and monoaxial—and has space for a wide variety of rod, connector, and hook caddies.
- The Universal Reduction Implant Kit is designed to accept any 3 reduction screw caddies and includes drivers, anti-splay sleeves, and the tab breaker.
- Both the Universal Implant Kit and the Universal Reduction Kit include a caddy with 40 closure tops, in order to accommodate larger, more complex cases.

Fits up to 3 polyaxial reduction or uniplanar reduction caddies. Each caddy holds 60 screws, from lengths of 20 mm to 60 mm

Closer top caddy always included



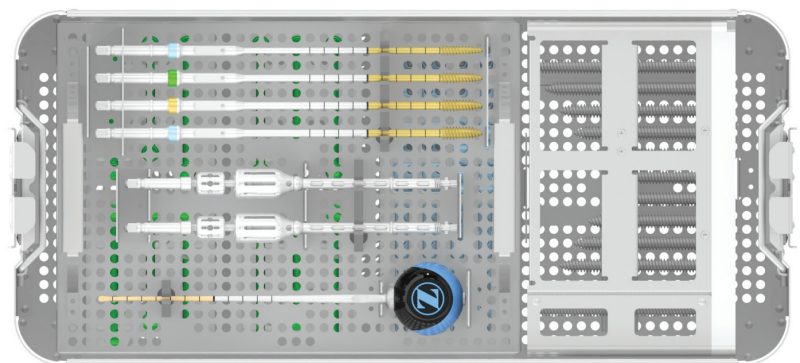
Upper



Lower

Reduction Kit

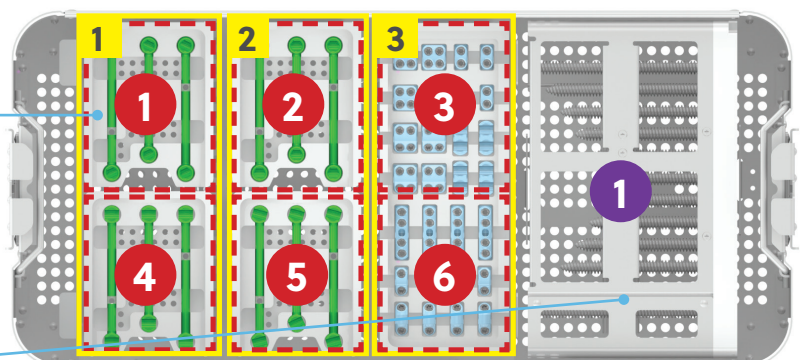
- The Iliac Implant and Instrument kit features cannulated taps and drivers, as well as a pelvic probe. This kit is designed to accept either open, or closed, polyaxial iliac screws, as well as an assortment of connector caddies.



Upper

Space for lateral offset connector caddies

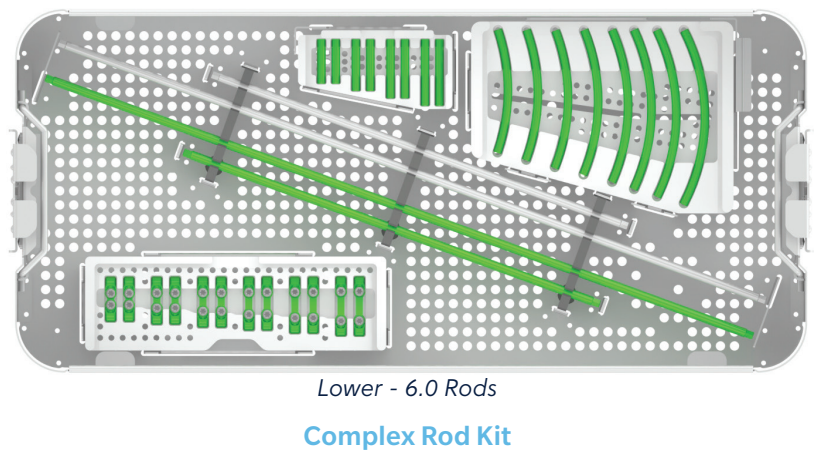
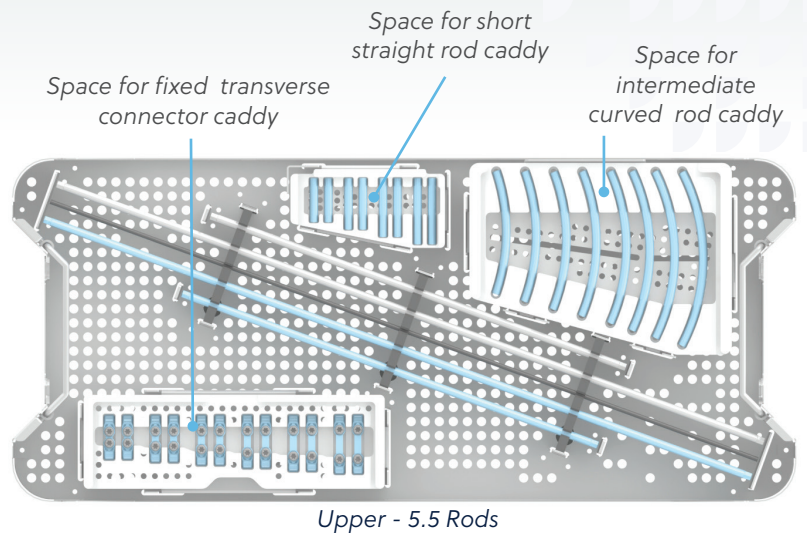
Space for 1 iliac screw caddy: open or closed



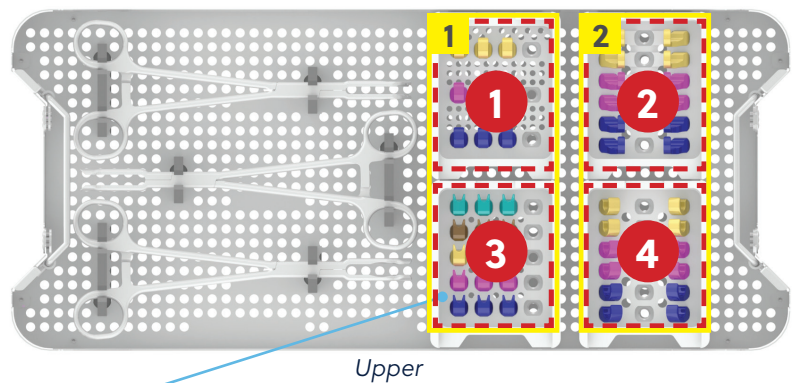
Lower

Iliac Implant and Instrument Kit

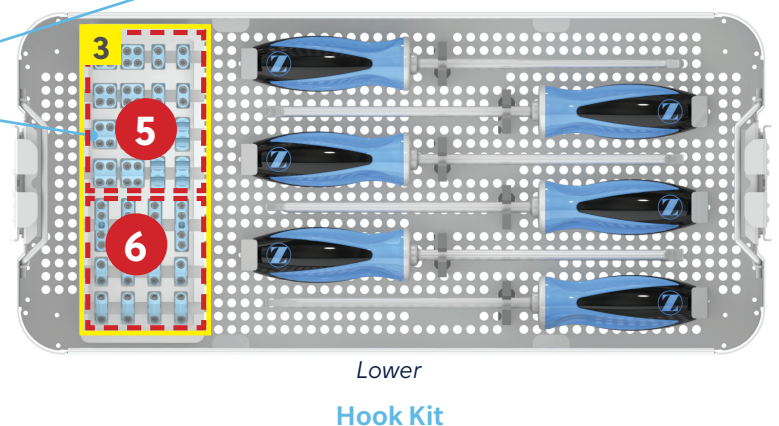
- The Complex Rod Kit includes a variety of long, straight titanium and cobalt chrome rod options. A variety of transverse connector caddies and pre-cut rod caddies may be ordered independently and then added to this set.



- The Hook Instrument Kit features various hook site prep instruments and hook inserters. This kit is designed to hold up to 6 hook caddies. These spaces may also be used to house a wide variety of connector caddies and the 6.0 mm pre-cut/pre-contoured rods (30-80 mm).



Space for hook caddies, rod-to-rod connectors, adjustable transverse connectors, lateral offset connectors and short curved rods



## Kit Ordering Overview *(continued)*

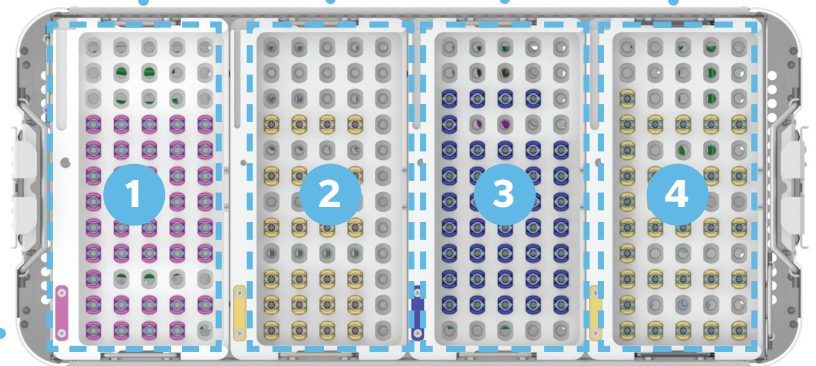
- The Cannulated Implant and Instrument kit features cannulated taps and drivers, as well as guidewires. The kit is designed to accept 4 standard pedicle screw caddies – polyaxial, uniplanar, and monoaxial – and has space for a wide variety of rod, connector, and hook caddies.

*Upper level can fit up to 4 screw caddies – Polyaxial, Uniplanar, monoaxial.*

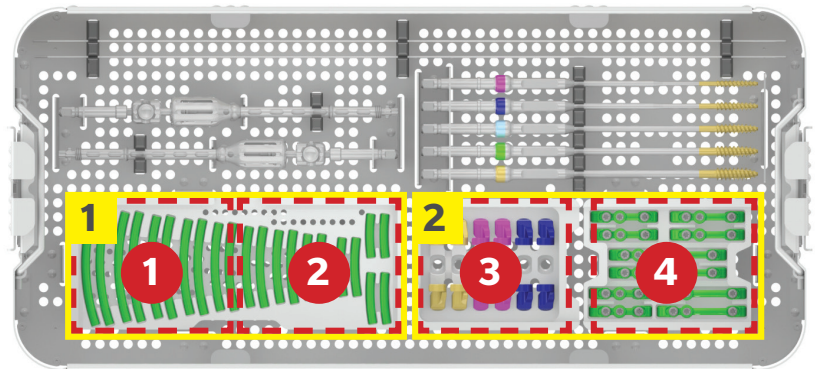
*\*Will not fit Iliac or reduction screws.*

*Lower level can fit combination of: Rod to rod connectors, adjustable transverse connectors, lateral offset connectors, short curved rods, or hooks*

Each ¼ caddy holds 60 screws, from lengths of 20 mm to 60 mm



Upper

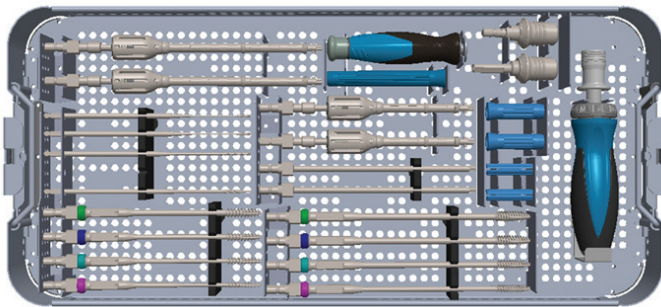


Lower

### Cannulated Implant and instrument Kit



## Kit Contents



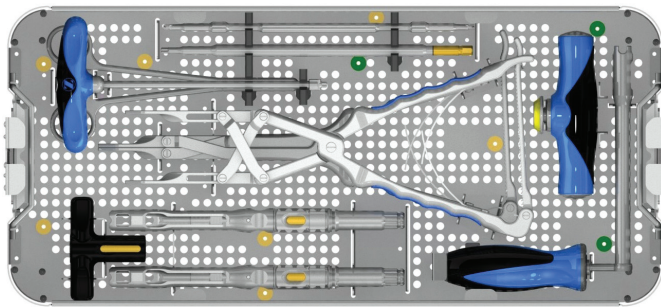
### Vital Power Instrument Kit Kit Number: PCR700M2101

DESCRIPTION	QTY	PART NUMBER
Standard Threaded Driver (non-locking)	2	731M0000
Short Threaded Driver (non-locking)	2	731M0001
Stab-N-Grab Driver	2	731M0010
Stab-N-Grab Sleeve	1	731M0005
Threaded Screwdriver Sleeve, Standard	1	07.02131.001
Threaded Screwdriver Sleeve, Short	1	07.02131.003
Pilot Drill, ø2.4 mm	2	731M0040
Reamer Probe, ø3.0 mm	1	731M0031
Optional Reamer Probe, ø3.2 mm	1	731M0030
Standard Drill, ø2.0 mm	1	731M0021
Adapter, Tri Flat to ¼" Sq	1	731M9000
Adapter, Z-Connect to ¼" Sq	1	731M9001
ø4.5 mm Tap, Z-Connect	1	731M0145
ø5.5 mm Tap, Z-Connect	1	731M0155
ø6.5 mm Tap, Z-Connect	1	731M0165
ø7.5 mm Tap, Z-Connect	1	731M0175
ø6.5 mm Iliac Tap, Z-Connect	1	731M0265
ø7.5 mm Iliac Tap, Z-Connect	1	731M0275
ø8.5 mm Iliac Tap, Z-Connect	1	731M0285
ø9.5 mm Iliac Tap, Z-Connect	1	731M0295
Ratcheting Axial Handle, Z-Connect	1	731M9002
Small AO Axial Handle	1	07.01788.001

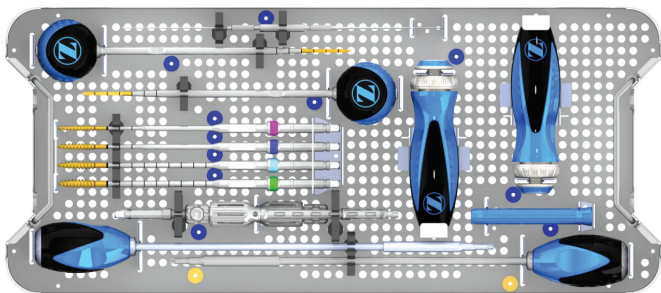
### Capital Equipment (not available through ZimVie, contact Zimmer Biomet Surgical Solutions)

DESCRIPTION	PART NUMBER
Double Trigger Handpiece	89-8507-400-00
Single Trigger Handpiece	89-8507-400-10
Small AO 1000RPM	89-8509-410-20
Zimmer/Hudson Attachment 250 RPM	89-8509-425-80

## Kit Contents (continued)



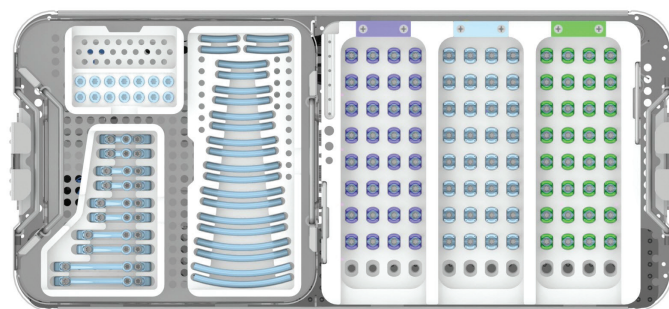
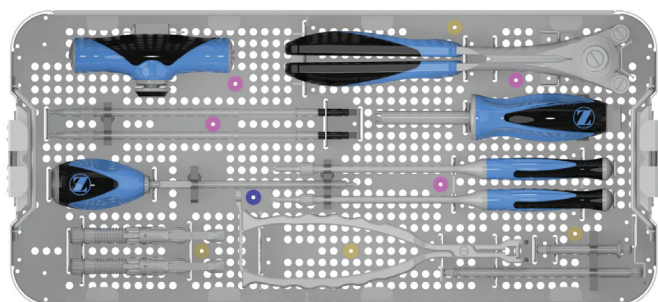
Upper



Lower

### Vital Instrument Kit Kit Number: PCR700M4101

DESCRIPTION	QTY	PART NUMBER
Adult Degen/Deformity Reducer	2	730M0021
Reducer T-handle	1	730M0022
Screwdriver, Standard	2	07.02054.001
Quick Connect — Ratcheting Handle, Straight	2	07.02051.001
Rod Holder	1	07.02064.001
Head-Height Adjuster	1	07.02060.001
Pedicle Probe, Straight — Lumbar	1	730M1001
Pedicle Probe, Curved — Lumbar Lenke	1	730M1004
Tap 4.5 mm	1	730M3045
Tap 5.5 mm	1	730M3055
Tap 6.5 mm	1	730M3065
Tap 7.5 mm	1	730M3075
Ball Tip Probe — Dual-ended Stiff/Flexible	1	07.02117.001
Compressor	1	07.02089.001
Distractor	1	07.02109.001
T27 Provisional Driver	2	730M0019
Counter-torque	1	730M0016
Torque-limiting Handle, 90 in-lb	1	07.02053.001
T27 Driver, Final	2	730M0017
Dual-ended Closure Starter	1	730M0018
Screw Driver Sleeve	2	07.02131.001

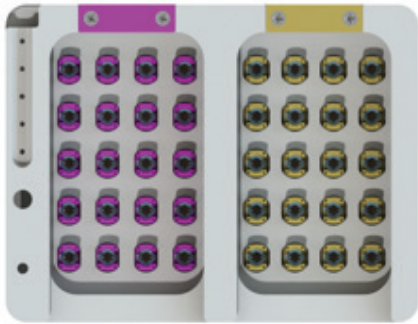


### Implant and Additional Instrument Kit Kit Number: PCR700M4111

DESCRIPTION	QTY	PART NUMBER
Rocket Threaded Reducer	1	730M0024
Quick Connect Adapter - Short	1	730M0023
Quick Connect Adapter - Long	1	730M0005
Rod Rocker	1	07.02093.001
Bone Awl	1	07.02076.001
French Bender	1	07.02092.001
T20 Provisional Driver	2	07.02119.001
T20 Driver, Final	2	07.02063.001
Torque-limiting Driver — 50 in-lb (5.65Nm)	1	07.02118.001
Counter-torque — Transverse Connector	1	07.02121.001
ø5.5 mm × 35 mm Polyaxial Screw	4	701M5535
ø5.5 mm × 40 mm Polyaxial Screw	8	701M5540
ø5.5 mm × 45 mm Polyaxial Screw	8	701M5545
ø5.5 mm × 50 mm Polyaxial Screw	8	701M5550
ø5.5 mm × 55 mm Polyaxial Screw	4	701M5555
ø6.5 mm × 35 mm Polyaxial Screw	4	701M6535
ø6.5 mm × 40 mm Polyaxial Screw	8	701M6540
ø6.5 mm × 45 mm Polyaxial Screw	8	701M6545
ø6.5 mm × 50 mm Polyaxial Screw	8	701M6550
ø6.5 mm × 55 mm Polyaxial Screw	4	701M6555
ø7.5 mm × 35 mm Polyaxial Screw	4	701M7535
ø7.5 mm × 40 mm Polyaxial Screw	8	701M7540
ø7.5 mm × 45 mm Polyaxial Screw	8	701M7545
ø7.5 mm × 50 mm Polyaxial Screw	8	701M7550
ø7.5 mm × 55 mm Polyaxial Screw	4	701M7555
ø5.5 mm–6.0 mm Standard Closure Top	14	07.02010.001

DESCRIPTION	QTY	PART NUMBER
ø5.5 mm × 30 mm Rod, Curved	4	07.02015.003
ø5.5 mm × 35 mm Rod, Curved	4	07.02015.004
ø5.5 mm × 40 mm Rod, Curved	4	07.02015.005
ø5.5 mm × 45 mm Rod, Curved	4	07.02015.006
ø5.5 mm × 50 mm Rod, Curved	4	07.02015.007
ø5.5 mm × 55 mm Rod, Curved	4	07.02015.008
ø5.5 mm × 60 mm Rod, Curved	4	07.02015.009
ø5.5 mm × 65 mm Rod, Curved	4	07.02015.010
ø5.5 mm × 70 mm Rod, Curved	4	07.02015.011
ø5.5 mm × 75 mm Rod, Curved	4	07.02015.012
ø5.5 mm × 80 mm Rod, Curved	4	07.02015.013
Transverse Connector Adjustable, 33-36 mm Wide x 5.5 mm	2	07.02030.001
Transverse Connector Adjustable, 36-41 mm Wide x 5.5 mm	2	07.02030.002
Transverse Connector Adjustable, 41-51 mm Wide x 5.5 mm	2	07.02030.003
Transverse Connector Adjustable, 51-70 mm Wide x 5.5 mm	2	07.02030.004
Transverse Connector Adjustable, 70-90 mm Wide x 5.5 mm	2	07.02030.005

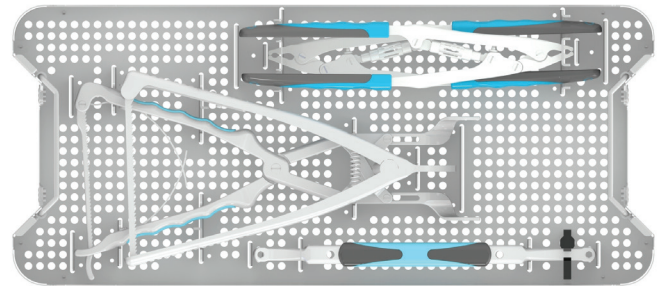
## Kit Contents (continued)



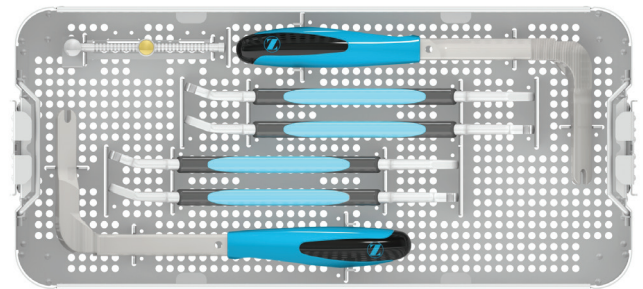
### Vital 4.5 mm/8.5 mm Auxiliary Implant Caddy PCR700M4995\*

DESCRIPTION	QTY	PART NUMBER
ø4.5 mm × 30 mm Polyaxial Screw	4	701M4530
ø4.5 mm × 35 mm Polyaxial Screw	4	701M4535
ø4.5 mm × 40 mm Polyaxial Screw	4	701M4540
ø4.5 mm × 45 mm Polyaxial Screw	4	701M4545
ø4.5 mm × 50 mm Polyaxial Screw	4	701M4550
ø8.5 mm × 40 mm Polyaxial Screw	4	709M8540
ø8.5 mm × 45 mm Polyaxial Screw	4	709M8545
ø8.5 mm × 50 mm Polyaxial Screw	4	709M8550
ø8.5 mm × 55 mm Polyaxial Screw	4	709M8555
ø8.5 mm × 60 mm Polyaxial Screw	4	709M8560

\*Independent caddy that does not fit in any kit



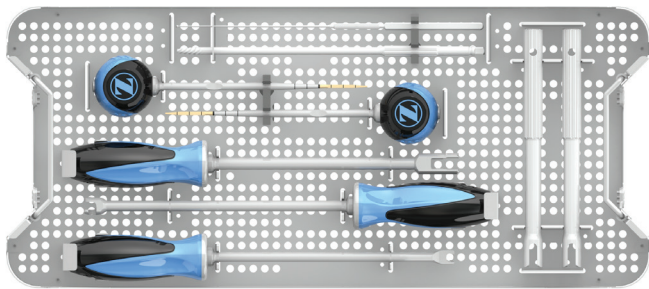
Upper



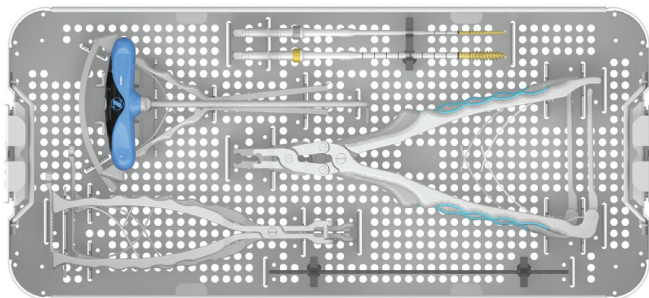
Lower

### Vital Complex Instrument Kit 1 Kit Number: PCR700M5021

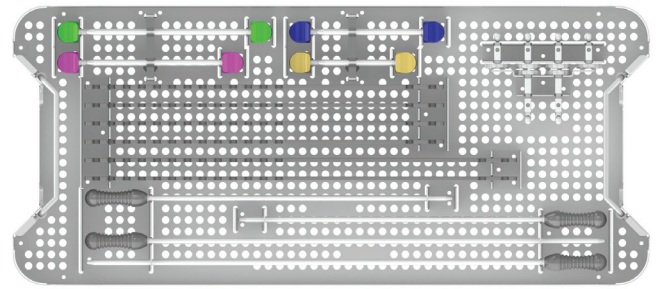
DESCRIPTION	QTY	PART NUMBER
Vise Grips	2	07.02104.001
Hex End Rod Rotation Tool	2	07.02127.001
Sagittal Bender - 5.5 mm Left	1	07.02091.001
Sagittal Bender - 5.5 mm Right	1	07.02091.002
Sagittal Bender - 6.0 mm Left	1	07.02102.001
Sagittal Bender - 6.0 mm Right	1	07.02102.002
Left Coronal Bender	1	730M0011
Right Coronal Bender	1	730M0012
Coronal Bender Fulcrum	1	730M0013
Compressor - Multi-Level	1	07.02090.001
Distractor (Single Pivot)	1	730M0039



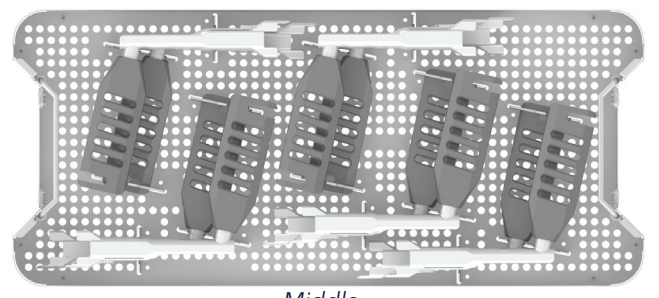
Upper



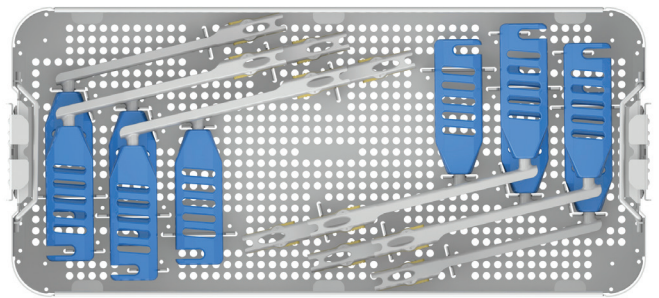
Lower



Upper



Middle



Lower

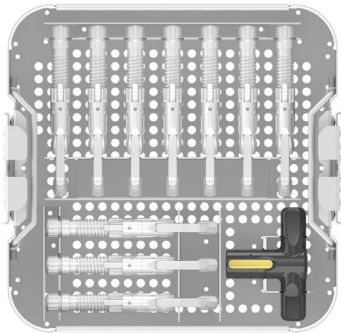
### Vital Complex Instrument Kit 2 Kit Number: PCR700M5031

DESCRIPTION	QTY	PART NUMBER
Pedicle Probe - Thoracic Straight	1	730M1005
Pedicle Probe - Thoracic Curved	1	730M1006
Tap 3.5 mm	1	730M3035
Tap 8.5 mm	1	730M3085
Ball Tip Probe - Single Ended Stiff - Standard	1	07.02115.001
Fixed Screw Height Adjuster	1	730M0003
Bone Planer	1	730M0004
Rod Pusher	1	07.02101.001
Rod Manipulator	1	730M0015
Tube Rod Pusher	2	730M0014
Rod Gripper	2	07.02100.001
Rod Rocker, Long	1	730M0037
T27 Easy Out Removal Driver	1	07.02065.001
Caliper - Transverse Connector	1	07.02111.001
Rod Template - 250 mm	1	07.02099.002
Rod to Rod Connector Holder	1	07.02123.001

### Vital Derotation Instruments Kit Kit Number: PCR700M5041

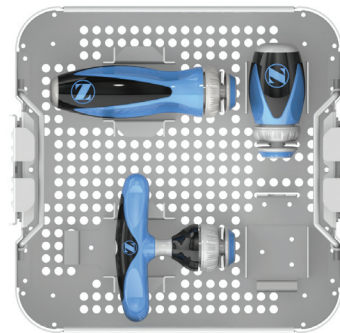
DESCRIPTION	QTY	PART NUMBER
Derotator	10	730M0000
DeRoducer	10	14-500204
2-3 Handle Linkage Rod	4	14-501003
3-4 Handle Linkage Rod	4	14-501004
4-5 Handle Linkage Rod	4	14-501005
5-6 Handle Linkage Rod	4	730M0043
25 cm Cluster Rod	2	14-501006
38 cm Cluster Rod	2	14-501007
30 cm Comb	4	14-501008
36 cm Comb	2	14-501009
Segmental Linkage	4	730M0054
Multilevel Linkage	2	730M0053

## Kit Contents (continued)



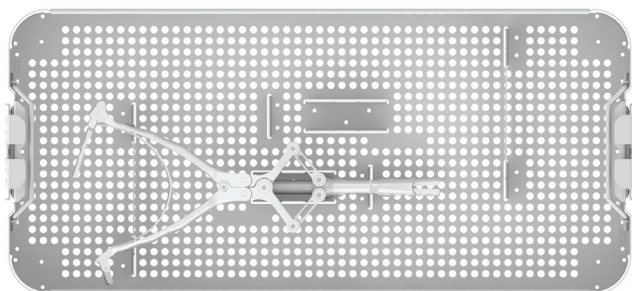
**Rocket Kit**  
Kit Number: PCR700M5051

DESCRIPTION	QTY	PART NUMBER
Short Rocket Reducer	10	730M0024
Reducer T-Handle	1	730M0022



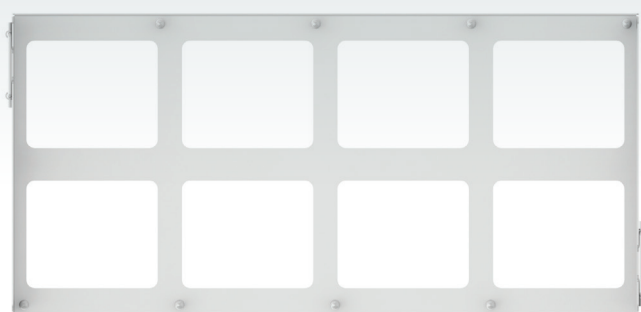
**Handles Kit**  
Kit Number: PCR700M5101

DESCRIPTION	QTY	PART NUMBER
Ratcheting Straight Handle	1	07.02051.001
Ratcheting T-Handle	1	07.02052.001
Ratcheting Palm Handle	1	07.02105.001

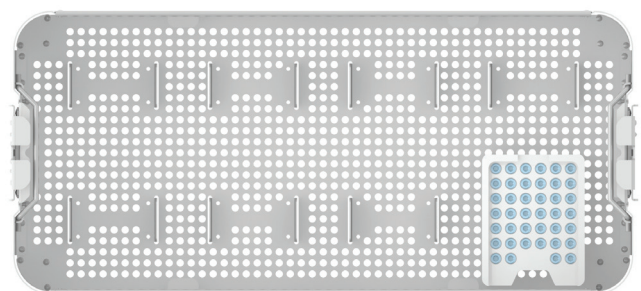


**Single Action Reducer Kit**  
Kit Number: PCR700M5081

DESCRIPTION	QTY	PART NUMBER
Single Action Reducer	1	730M0026



Upper



Lower

### Universal Implant Kit PCR700M5001

DESCRIPTION	QTY	PART NUMBER
ø5.5 mm-6.0 mm Standard Closure Top	40	07.02010.001

### Compatible Implant Caddies

#### Universal Implant Kit Accepts up to 3 of the following:

DESCRIPTION	PART NUMBER
ø6.0 mm Curved Rods	PCR700M1216
ø5.5-6.0 mm Rod Connectors	PCR700M5056
ø3.5 mm x ø5.5-6.0 mm Rod Connectors	PCR700M5035

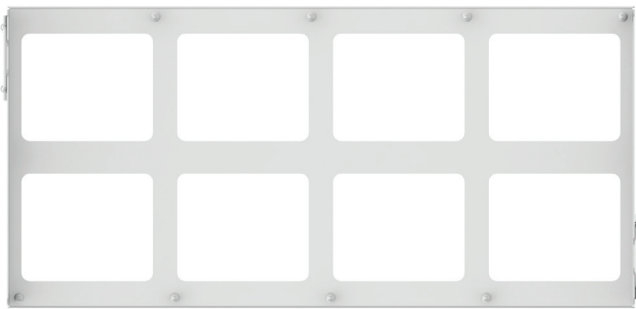
#### Universal Implant Kit Accepts up to 7 of the following:

DESCRIPTION	PART NUMBER
Open Straight Lateral Offset Connectors	PCR700M3001
Open 15° Lateral Offset Connectors	PCR700M3151
Open 25° Lateral Offset Connectors	PCR700M3251
Closed Straight Lateral Offset Connectors	PCR700M3002
Closed 15° Lateral Offset Connectors	PCR700M3152
Closed 25° Lateral Offset Connectors	PCR700M3252
ø6.0 mm Adjustable Transverse Connectors	PCR700M4206
Pedicle Hooks	PCR700M6001
Angled Hooks	PCR700M6002
Laminar Hooks	PCR700M6003
Narrow Laminar Hooks	PCR700M6004
Narrow Reduced Laminar Hooks	PCR700M6005
Offset Hooks	PCR700M6006
Angled Blade Hooks	PCR700M6007
Extended Laminar Hooks	PCR700M6008
Transverse Process Hooks	PCR700M6009

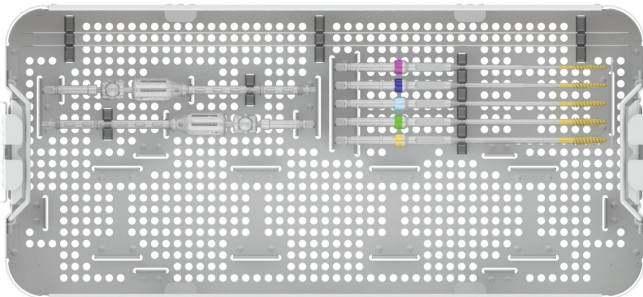
#### Universal Implant Kit accepts 4 total of the following:

DESCRIPTION	PART NUMBER
ø4.0 mm Polyaxial Screws	PCR700M0140
ø4.5 mm Polyaxial Screws	PCR700M0145
ø5.0 mm Polyaxial Screws	PCR700M0150
ø5.5 mm Polyaxial Screws	PCR700M0155
ø6.0 mm Polyaxial Screws	PCR700M0160
ø6.5 mm Polyaxial Screws	PCR700M0165
ø7.0 mm Polyaxial Screws	PCR700M0170
ø7.5 mm Polyaxial Screws	PCR700M0175
ø8.5 mm Polyaxial Screws	PCR700M0185
ø9.5 mm Polyaxial Screws	PCR700M0195
ø10.5 mm Polyaxial Screws	PCR700M0115
ø4.5 mm Uniplanar Screws	PCR700M0345
ø5.0 mm Uniplanar Screws	PCR700M0350
ø5.5 mm Uniplanar Screws	PCR700M0355
ø6.0 mm Uniplanar Screws	PCR700M0360
ø6.5 mm Uniplanar Screws	PCR700M0365
ø7.5 mm Uniplanar Screws	PCR700M0375
ø4.0 mm Monoaxial Screws	PCR700M0540
ø4.5 mm Monoaxial Screws	PCR700M0545
ø5.5 mm Monoaxial Screws	PCR700M0555
ø6.5 mm Monoaxial Screws	PCR700M0565
ø7.5 mm Monoaxial Screws	PCR700M0575
ø4.5 mm Cannulated Polyaxial Screws	PCR800M0145
ø5.0 mm Cannulated Polyaxial Screws	PCR800M0150
ø5.5 mm Cannulated Polyaxial Screws	PCR800M0155
ø6.0 mm Cannulated Polyaxial Screws	PCR800M0160
ø6.5 mm Cannulated Polyaxial Screws	PCR800M0165
ø7.0 mm Cannulated Polyaxial Screws	PCR800M0170
ø7.5 mm Cannulated Polyaxial Screws	PCR800M0175
ø8.5 mm Cannulated Polyaxial Screws	PCR800M0185
ø9.5 mm Cannulated Polyaxial Screws	PCR800M0195
ø4.5 mm Cannulated Uniplanar Screws	PCR800M0345
ø5.0 mm Cannulated Uniplanar Screws	PCR800M0350
ø5.5 mm Cannulated Uniplanar Screws	PCR800M0355
ø6.0 mm Cannulated Uniplanar Screws	PCR800M0360
ø6.5 mm Cannulated Uniplanar Screws	PCR800M0365
ø7.5 mm Cannulated Uniplanar Screws	PCR800M0375
ø4.5 mm Cannulated Monoaxial Screws	PCR800M0545
ø5.5 mm Cannulated Monoaxial Screws	PCR800M0555
ø6.5 mm Cannulated Monoaxial Screws	PCR800M0565
ø7.5 mm Cannulated Monoaxial Screws	PCR800M0575

## Kit Contents (continued)



Upper



Lower

### Cannulated Instrument Kit Kit Number: PCR800M1500

DESCRIPTION	QTY	PART NUMBER
K-Wire Blunt	8	14-500360
K-Wire Trochar	8	14-500361
Cannulated Screwdriver	2	730M0060
Cannulated Tap 4.5mm	1	735M0145
Cannulated Tap 5.5mm	1	735M0155
Cannulated Tap 6.5mm	1	735M0165
Cannulated Tap 7.5mm	1	735M0175
Cannulated Tap 8.5mm	1	735M0185

### Compatible Implant Caddies

**Cannulated Instrument Kit accepts up to 2 of the following:**

DESCRIPTION	PART NUMBER
ø6.0 mm Curved Rods	PCR700M1216
ø5.5-6.0 mm Rod Connectors	PCR700M5056
ø3.5 mm x ø5.5-6.0 mm Rod Connectors	PCR700M5035

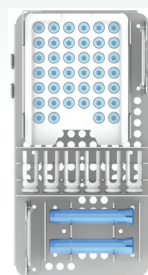
**Cannulated Instrument Kit accepts 4 total of the following screw caddies:**

DESCRIPTION	PART NUMBER
ø4.0 mm Polyaxial Screws	PCR700M0140
ø4.5 mm Polyaxial Screws	PCR700M0145
ø5.0 mm Polyaxial Screws	PCR700M0150
ø5.5 mm Polyaxial Screws	PCR700M0155
ø6.0 mm Polyaxial Screws	PCR700M0160
ø6.5 mm Polyaxial Screws	PCR700M0165
ø7.0 mm Polyaxial Screws	PCR700M0170
ø7.5 mm Polyaxial Screws	PCR700M0175
ø8.5 mm Polyaxial Screws	PCR700M0185
ø9.5 mm Polyaxial Screws	PCR700M0195
ø10.5 mm Polyaxial Screws	PCR700M0115
ø4.5 mm Uniplanar Screws	PCR700M0345
ø5.0 mm Uniplanar Screws	PCR700M0350
ø5.5 mm Uniplanar Screws	PCR700M0355
ø6.0 mm Uniplanar Screws	PCR700M0360
ø6.5 mm Uniplanar Screws	PCR700M0365
ø7.5 mm Uniplanar Screws	PCR700M0375
ø4.0 mm Monoaxial Screws	PCR700M0540
ø4.5 mm Monoaxial Screws	PCR700M0545
ø5.5 mm Monoaxial Screws	PCR700M0555
ø6.5 mm Monoaxial Screws	PCR700M0565
ø7.5 mm Monoaxial Screws	PCR700M0575
ø4.5 mm Cannulated Polyaxial Screws	PCR800M0145
ø5.0 mm Cannulated Polyaxial Screws	PCR800M0150
ø5.5 mm Cannulated Polyaxial Screws	PCR800M0155
ø6.0 mm Cannulated Polyaxial Screws	PCR800M0160
ø6.5 mm Cannulated Polyaxial Screws	PCR800M0165
ø7.0 mm Cannulated Polyaxial Screws	PCR800M0170
ø7.5 mm Cannulated Polyaxial Screws	PCR800M0175
ø8.5 mm Cannulated Polyaxial Screws	PCR800M0185
ø9.5 mm Cannulated Polyaxial Screws	PCR800M0195
ø4.5 mm Cannulated Uniplanar Screws	PCR800M0345
ø5.0 mm Cannulated Uniplanar Screws	PCR800M0350
ø5.5 mm Cannulated Uniplanar Screws	PCR800M0355
ø6.0 mm Cannulated Uniplanar Screws	PCR800M0360
ø6.5 mm Cannulated Uniplanar Screws	PCR800M0365
ø7.5 mm Cannulated Uniplanar Screws	PCR800M0375
ø4.5 mm Cannulated Monoaxial Screws	PCR800M0545
ø5.5 mm Cannulated Monoaxial Screws	PCR800M0555
ø6.5 mm Cannulated Monoaxial Screws	PCR800M0565
ø7.5 mm Cannulated Monoaxial Screws	PCR800M0575

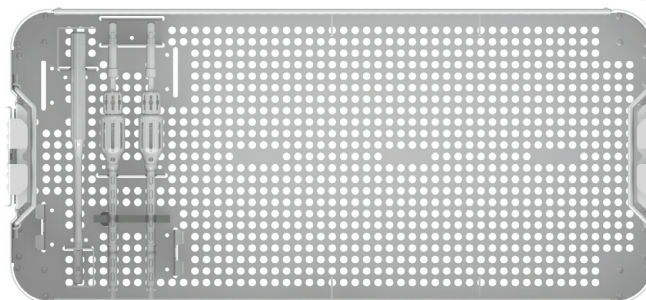


**Cannulated Instrument Kit accepts up to 4 of the following:**

DESCRIPTION	PART NUMBER
Open Straight Lateral Offset Connectors	PCR700M3001
Open 15° Lateral Offset Connectors	PCR700M3151
Open 25° Lateral Offset Connectors	PCR700M3251
Closed Straight Lateral Offset Connectors	PCR700M3002
Closed 15° Lateral Offset Connectors	PCR700M3152
Closed 25° Lateral Offset Connectors	PCR700M3252
ø6.0 mm Adjustable Transverse Connectors	PCR700M4206
Pedicle Hooks	PCR700M6001
Angled Hooks	PCR700M6002
Laminar Hooks	PCR700M6003
Narrow Laminar Hooks	PCR700M6004
Narrow Reduced Laminar Hooks	PCR700M6005
Offset Hooks	PCR700M6006
Angled Blade Hooks	PCR700M6007
Extended Laminar Hooks	PCR700M6008
Transverse Process Hooks	PCR700M6009



Upper



Lower

**Reduction Implant Kit  
Kit Number: PCR700M5071**

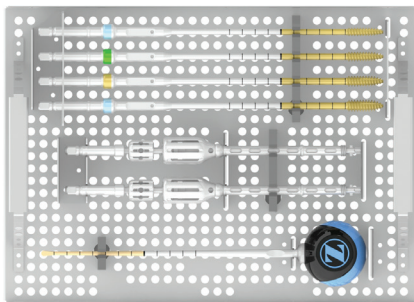
DESCRIPTION	QTY	PART NUMBER
Reduction Tab Removal Tool	1	07.02074.001
Reduction Tab Sleeve	6	730M0038
Reduction Screwdriver	2	07.02058.001
Screwdriver Sleeve - Reduction	2	07.02131.002
ø5.5 mm – 6.0 mm Closure Top	40	07.02010.001

**Compatible Implant Caddies**

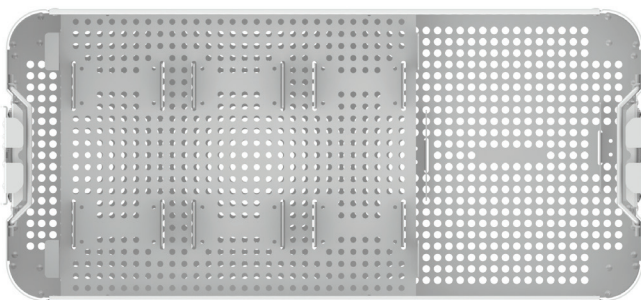
**Reduction Implant Kit accepts a total of 3 of the following reduction screw caddies**

DESCRIPTION	PART NUMBER
ø4.5 mm Polyaxial Reduction Screws	PCR700M0245
ø5.0 mm Polyaxial Reduction Screws	PCR700M0250
ø5.5 mm Polyaxial Reduction Screws	PCR700M0255
ø6.0 mm Polyaxial Reduction Screws	PCR700M0260
ø6.5 mm Polyaxial Reduction Screws	PCR700M0265
ø7.0 mm Polyaxial Reduction Screws	PCR700M0270
ø7.5 mm Polyaxial Reduction Screws	PCR700M0275
ø8.5 mm Polyaxial Reduction Screws	PCR700M0285
ø4.5 mm Uniplanar Reduction Screws	PCR700M0445
ø5.0 mm Uniplanar Reduction Screws	PCR700M0450
ø5.5 mm Uniplanar Reduction Screws	PCR700M0455
ø6.0 mm Uniplanar Reduction Screws	PCR700M0460
ø6.5 mm Uniplanar Reduction Screws	PCR700M0465

## Kit Contents (continued)



Upper



Lower

### Iliac Instrument Kit Kit Number: PCR700M5061

DESCRIPTION	QTY	PART NUMBER
Cannulated Screwdriver	2	730M0060
Pedicle Probe - Iliac	1	730M1007
Cannulated Tap 6.5 mm - Iliac	1	730M5065
Cannulated Tap 7.5 mm - Iliac	1	730M5075
Cannulated Tap 8.5 mm - Iliac	1	730M5085
Cannulated Tap 9.5 mm - Iliac	1	730M5095

### Compatible Implant Caddies

**Iliac Instrument Kit accepts up to 1 of the following iliac screw caddies:**

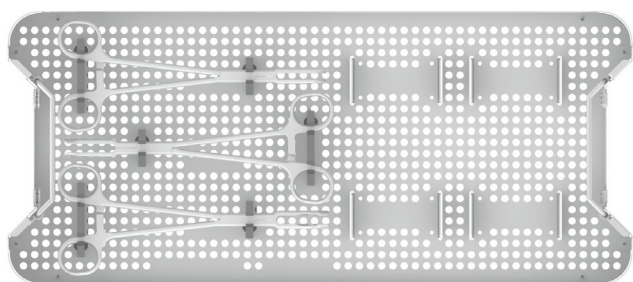
DESCRIPTION	PART NUMBER
Open Iliac Screws	PCR700M0601
Closed Iliac Screws	PCR700M0602
Cannulated Open Iliac Screws	PCR800M0601

**Iliac Instrument Kit accepts up to 3 of the following implant caddies:**

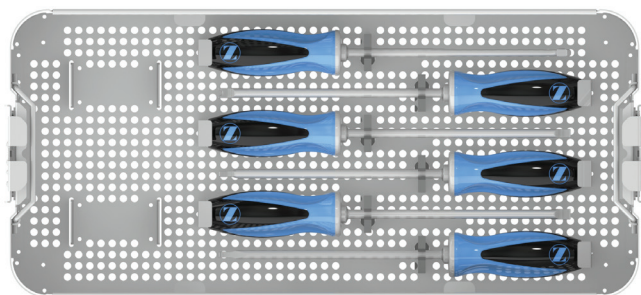
DESCRIPTION	PART NUMBER
ø6.0 mm Curved Rods	PCR700M1216
ø5.5-6.0 mm Rod Connectors	PCR700M5056
ø3.5 mm x ø5.5-6.0 mm Rod Connectors	PCR700M5035

**Iliac Instrument Kit accepts up to 6 of the following implant caddies:**

DESCRIPTION	PART NUMBER
Open Straight Lateral Offset Connectors	PCR700M3001
Open 15° Lateral Offset Connectors	PCR700M3151
Open 25° Lateral Offset Connectors	PCR700M3251
Closed Straight Lateral Offset Connectors	PCR700M3002
Closed 15° Lateral Offset Connectors	PCR700M3152
Closed 25° Lateral Offset Connectors	PCR700M3252
ø6.0 mm Adjustable Transverse Connectors	PCR700M4206
Pedicle Hooks	PCR700M6001
Angled Hooks	PCR700M6002
Laminar Hooks	PCR700M6003
Narrow Laminar Hooks	PCR700M6004
Narrow Reduced Laminar Hooks	PCR700M6005
Offset Hooks	PCR700M6006
Angled Blade Hooks	PCR700M6007
Extended Laminar Hooks	PCR700M6008
Transverse Process Hooks	PCR700M6009



Upper



Lower

### Hook Instrument Kit PCR700M5111

DESCRIPTION	QTY	PART NUMBER
Vertical Hook Holder	2	730M0027
Angled Hook Holder	2	730M0028
Side Hook Holder	2	730M0029
Hook Impactor	1	730M0030
Pedicle Hook Starter	1	730M0031
Wide Laminar Hook Starter	1	730M0032
Narrow Laminar Hook Starter	1	730M0034
Thoracic Hook Starter	1	730M0035
TP Hook Starter	1	730M0052

### Compatible Implant Caddies

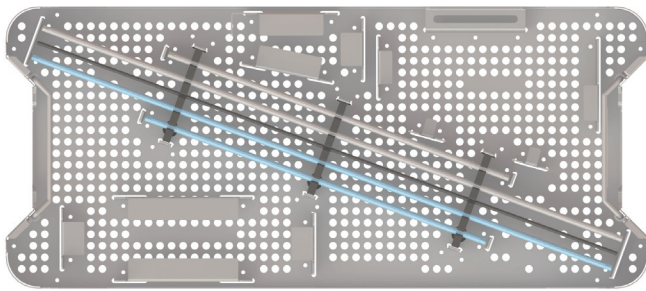
**Hook Instrument Kit accepts up to 6 of the following implant caddies**

DESCRIPTION	PART NUMBER
Pedicle Hooks	PCR700M6001
Angled Hooks	PCR700M6002
Laminar Hooks	PCR700M6003
Narrow Laminar Hooks	PCR700M6004
Narrow Reduced Laminar Hooks	PCR700M6005
Offset Hooks	PCR700M6006
Angled Blade Hooks	PCR700M6007
Extended Laminar Hooks	PCR700M6008
Transverse Process Hooks	PCR700M6009
Open Straight Lateral Offset Connectors	PCR700M3001
Open 15° Lateral Offset Connectors	PCR700M3151
Open 25° Lateral Offset Connectors	PCR700M3251
Closed Straight Lateral Offset Connectors	PCR700M3002
Closed 15° Lateral Offset Connectors	PCR700M3152
Closed 25° Lateral Offset Connectors	PCR700M3252
ø6.0 mm Adjustable Transverse Connectors	PCR700M4206

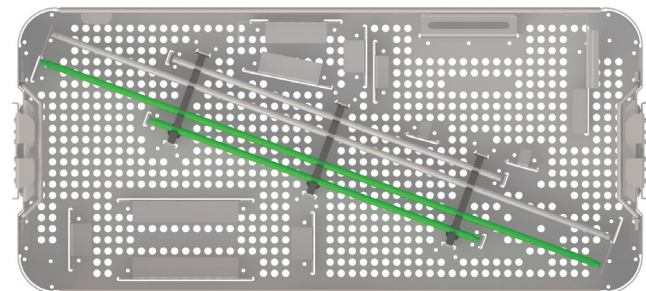
**Hook Instrument Kit accepts up to 3 of the following implant caddies**

DESCRIPTION	PART NUMBER
ø6.0 mm Curved Rods	PCR700M1216
ø5.5-6.0 mm Rod Connectors	PCR700M5056
ø3.5 mm x ø5.5-6.0 mm Rod Connectors	PCR700M5035

## Kit Contents (continued)



Upper



Lower

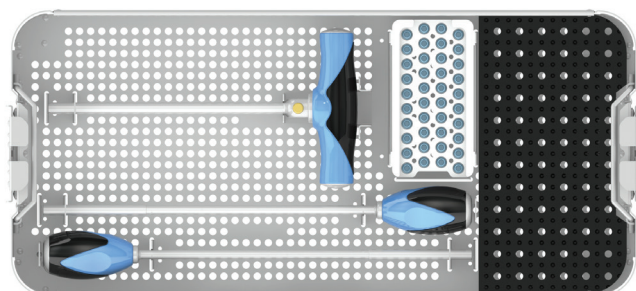
### Complex Rods Kit PCR700M5011

DESCRIPTION	QTY	PART NUMBER
ø5.5 x 300 mm, Straight Rod, Ti	4	07.02013.001
ø5.5 x 300 mm, Straight Rod, CoCr	4	07.02016.001
ø5.5 x 510 mm, Straight Rod, Ti	4	07.02013.003
ø5.5 x 510 mm, Straight Rod, CoCr	4	07.02016.003
ø6.0 x 300 mm, Straight Rod, Ti	4	07.02019.001
ø6.0 x 300 mm, Straight Rod, CoCr	4	07.02022.001
ø6.0 x 510 mm, Straight Rod, Ti	4	07.02019.003
ø6.0 x 510 mm, Straight Rod, CoCr	4	07.02022.003
510 mm Rod Template	1	07.02099.004

### Compatible Implant Caddies

**Complex Rod Kit accepts 1 of each of the following:**

DESCRIPTION	PART NUMBER
ø5.5 mm Straight Rods	PCR700M1115
ø6.0 mm Straight Rods	PCR700M1116
ø5.5 mm Intermediate Curved Rods	PCR700M1225
ø6.0 mm Intermediate Curved Rods	PCR700M1226
ø5.5 mm Fixed Transverse Connectors	PCR700M4105
ø6.0 mm Fixed Transverse Connectors	PCR700M4106



### Shear-off Closure Top Kit PCR700M5091

DESCRIPTION	QTY	PART NUMBER
Shear-Off Closure Top	40	07.02011.001
Shear-Off Final Driver	1	730M0002
Shear-Off Closure Top Starter	2	730M0050

**Note:** Implant caddies may be sterilized and wrapped independently, or they may be inserted into the Universal Implant Kit, Reduction Implant Kit, Complex Rod Kit, Iliac Instrument Kit, Hook Instrument Kit, or the Cannulated Instrument Kit.



**Polyaxial Screws**

**ø4.0 mm Polyaxial Screws  
PCR700M0140**

DESCRIPTION	QTY	PART NUMBER
Polyaxial Screw, ø4.0 mm x 20 mm	4	701M4020
Polyaxial Screw, ø4.0 mm x 25 mm	4	701M4025
Polyaxial Screw, ø4.0 mm x 30 mm	4	701M4030
Polyaxial Screw, ø4.0 mm x 35 mm	4	701M4035
Polyaxial Screw, ø4.0 mm x 40 mm	4	701M4040
Polyaxial Screw, ø4.0 mm x 45 mm	4	701M4045

**ø4.5 mm Polyaxial Screws  
PCR700M0145**

DESCRIPTION	QTY	PART NUMBER
Polyaxial Screw, ø4.5 mm x 20 mm	4	701M4520
Polyaxial Screw, ø4.5 mm x 25 mm	4	701M4525
Polyaxial Screw, ø4.5 mm x 30 mm	4	701M4530
Polyaxial Screw, ø4.5 mm x 35 mm	4	701M4535
Polyaxial Screw, ø4.5 mm x 40 mm	4	701M4540
Polyaxial Screw, ø4.5 mm x 45 mm	4	701M4545

**ø5.0 mm Polyaxial Screws  
PCR700M0150**

DESCRIPTION	QTY	PART NUMBER
Polyaxial Screw, ø5.0 mm x 30 mm	6	701M5030
Polyaxial Screw, ø5.0 mm x 35 mm	6	701M5035
Polyaxial Screw, ø5.0 mm x 40 mm	6	701M5040
Polyaxial Screw, ø5.0 mm x 45 mm	4	701M5045
Polyaxial Screw, ø5.0 mm x 50 mm	4	701M5050

**ø5.5 mm Polyaxial Screws  
PCR700M0155**

DESCRIPTION	QTY	PART NUMBER
Polyaxial Screw, ø5.5 mm x 30 mm	10	701M5530
Polyaxial Screw, ø5.5 mm x 35 mm	10	701M5535
Polyaxial Screw, ø5.5 mm x 40 mm	10	701M5540
Polyaxial Screw, ø5.5 mm x 45 mm	6	701M5545
Polyaxial Screw, ø5.5 mm x 50 mm	4	701M5550

**ø6.0 mm Polyaxial Screws  
PCR700M0160**

DESCRIPTION	QTY	PART NUMBER
Polyaxial Screw, ø6.0 mm x 30 mm	6	701M6030
Polyaxial Screw, ø6.0 mm x 35 mm	6	701M6035
Polyaxial Screw, ø6.0 mm x 40 mm	6	701M6040
Polyaxial Screw, ø6.0 mm x 45 mm	6	701M6045
Polyaxial Screw, ø6.0 mm x 50 mm	6	701M6050

**ø6.5 mm Polyaxial Screws  
PCR700M0165**

DESCRIPTION	QTY	PART NUMBER
Polyaxial Screw, ø6.5 mm x 30 mm	4	701M6530
Polyaxial Screw, ø6.5 mm x 35 mm	6	701M6535
Polyaxial Screw, ø6.5 mm x 40 mm	10	701M6540
Polyaxial Screw, ø6.5 mm x 45 mm	10	701M6545
Polyaxial Screw, ø6.5 mm x 50 mm	10	701M6550

**ø7.0 mm Polyaxial Screws  
PCR700M0170**

DESCRIPTION	QTY	PART NUMBER
Polyaxial Screw, ø7.0 mm x 30 mm	4	701M7030
Polyaxial Screw, ø7.0 mm x 35 mm	6	701M7035
Polyaxial Screw, ø7.0 mm x 40 mm	10	701M7040
Polyaxial Screw, ø7.0 mm x 45 mm	10	701M7045
Polyaxial Screw, ø7.0 mm x 50 mm	10	701M7050

**ø7.5 mm Polyaxial Screws  
PCR700M0175**

DESCRIPTION	QTY	PART NUMBER
Polyaxial Screw, ø7.5 mm x 30 mm	4	701M7530
Polyaxial Screw, ø7.5 mm x 35 mm	4	701M7535
Polyaxial Screw, ø7.5 mm x 40 mm	6	701M7540
Polyaxial Screw, ø7.5 mm x 45 mm	6	701M7545
Polyaxial Screw, ø7.5 mm x 50 mm	6	701M7550

## Kit Contents (continued)

### Polyaxial Screws (continued)

#### ø8.5 mm Polyaxial Screws PCR700M0185

DESCRIPTION	QTY	PART NUMBER
Polyaxial Screw, ø8.5 mm x 30 mm	4	709M8530
Polyaxial Screw, ø8.5 mm x 35 mm	4	709M8535
Polyaxial Screw, ø8.5 mm x 40 mm	4	709M8540
Polyaxial Screw, ø8.5 mm x 45 mm	4	709M8545
Polyaxial Screw, ø8.5 mm x 50 mm	4	709M8550

#### ø9.5 mm Polyaxial Screws PCR700M0195

DESCRIPTION	QTY	PART NUMBER
Polyaxial Screw, ø9.5 mm x 30 mm	2	709M9530
Polyaxial Screw, ø9.5 mm x 35 mm	2	709M9535
Polyaxial Screw, ø9.5 mm x 40 mm	4	709M9540
Polyaxial Screw, ø9.5 mm x 45 mm	4	709M9545
Polyaxial Screw, ø9.5 mm x 50 mm	4	709M9550

### Cannulated Polyaxial Screws

#### ø4.5 mm Cannulated Polyaxial Screws PCR800M0145

DESCRIPTION	QTY	PART NUMBER
Cannulated Polyaxial Screw, ø4.5 mm x 20 mm	4	801M4520
Cannulated Polyaxial Screw, ø4.5 mm x 25 mm	4	801M4525
Cannulated Polyaxial Screw, ø4.5 mm x 30 mm	4	801M4530
Cannulated Polyaxial Screw, ø4.5 mm x 35 mm	4	801M4535
Cannulated Polyaxial Screw, ø4.5 mm x 40 mm	4	801M4540
Cannulated Polyaxial Screw, ø4.5 mm x 45 mm	4	801M4545

#### ø5.0 mm Cannulated Polyaxial Screws PCR800M0150

DESCRIPTION	QTY	PART NUMBER
Cannulated Polyaxial Screw, ø5.0 mm x 30 mm	6	801M5030
Cannulated Polyaxial Screw, ø5.0 mm x 35 mm	6	801M5035
Cannulated Polyaxial Screw, ø5.0 mm x 40 mm	6	801M5040
Cannulated Polyaxial Screw, ø5.0 mm x 45 mm	4	801M5045
Cannulated Polyaxial Screw, ø5.0 mm x 50 mm	4	801M5050

#### ø10.5 mm Polyaxial Screws PCR700M0115

DESCRIPTION	QTY	PART NUMBER
Polyaxial Screw, ø10.5 mm x 30 mm	2	709M1530
Polyaxial Screw, ø10.5 mm x 35 mm	2	709M1535
Polyaxial Screw, ø10.5 mm x 40 mm	4	709M1540
Polyaxial Screw, ø10.5 mm x 45 mm	4	709M1545
Polyaxial Screw, ø10.5 mm x 50 mm	4	709M1550

#### ø5.5 mm Cannulated Polyaxial Screws PCR800M0155

DESCRIPTION	QTY	PART NUMBER
Cannulated Polyaxial Screw, ø5.5 mm x 30 mm	10	801M5530
Cannulated Polyaxial Screw, ø5.5 mm x 35 mm	10	801M5535
Cannulated Polyaxial Screw, ø5.5 mm x 40 mm	10	801M5540
Cannulated Polyaxial Screw, ø5.5 mm x 45 mm	6	801M5545
Cannulated Polyaxial Screw, ø5.5 mm x 50 mm	4	801M5550

#### ø6.0 mm Cannulated Polyaxial Screws PCR800M0160

DESCRIPTION	QTY	PART NUMBER
Cannulated Polyaxial Screw, ø6.0 mm x 30 mm	6	801M6030
Cannulated Polyaxial Screw, ø6.0 mm x 35 mm	6	801M6035
Cannulated Polyaxial Screw, ø6.0 mm x 40 mm	6	801M6040
Cannulated Polyaxial Screw, ø6.0 mm x 45 mm	6	801M6045
Cannulated Polyaxial Screw, ø6.0 mm x 50 mm	6	801M6050

**Cannulated Polyaxial Screws (continued)**

**ø6.5 mm Cannulated Polyaxial Screws  
PCR800M0165**

DESCRIPTION	QTY	PART NUMBER
Cannulated Polyaxial Screw, ø6.5 mm x 30 mm	4	801M6530
Cannulated Polyaxial Screw, ø6.5 mm x 35 mm	6	801M6535
Cannulated Polyaxial Screw, ø6.5 mm x 40 mm	10	801M6540
Cannulated Polyaxial Screw, ø6.5 mm x 45 mm	10	801M6545
Cannulated Polyaxial Screw, ø6.5 mm x 50 mm	10	801M6550

**ø7.0 mm Cannulated Polyaxial Screws  
PCR800M0170**

DESCRIPTION	QTY	PART NUMBER
Cannulated Polyaxial Screw, ø7.0 mm x 30 mm	4	801M7030
Cannulated Polyaxial Screw, ø7.0 mm x 35 mm	6	801M7035
Cannulated Polyaxial Screw, ø7.0 mm x 40 mm	10	801M7040
Cannulated Polyaxial Screw, ø7.0 mm x 45 mm	10	801M7045
Cannulated Polyaxial Screw, ø7.0 mm x 50 mm	10	801M7050

**ø7.5 mm Cannulated Polyaxial Screws  
PCR800M0175**

DESCRIPTION	QTY	PART NUMBER
Cannulated Polyaxial Screw, ø7.5 mm x 30 mm	4	801M7530
Cannulated Polyaxial Screw, ø7.5 mm x 35 mm	4	801M7535
Cannulated Polyaxial Screw, ø7.5 mm x 40 mm	6	801M7540
Cannulated Polyaxial Screw, ø7.5 mm x 45 mm	6	801M7545
Cannulated Polyaxial Screw, ø7.5 mm x 50 mm	6	801M7550

**ø8.5 mm Cannulated Polyaxial Screws  
PCR800M0185**

DESCRIPTION	QTY	PART NUMBER
Cannulated Polyaxial Screw, ø8.5 mm x 30 mm	4	802M8530
Cannulated Polyaxial Screw, ø8.5 mm x 35 mm	4	802M8535
Cannulated Polyaxial Screw, ø8.5 mm x 40 mm	4	802M8540
Cannulated Polyaxial Screw, ø8.5 mm x 45 mm	4	802M8545
Cannulated Polyaxial Screw, ø8.5 mm x 50 mm	4	802M8550

**ø9.5 mm Cannulated Polyaxial Screws  
PCR800M0195**

DESCRIPTION	QTY	PART NUMBER
Cannulated Polyaxial Screw, ø9.5 mm x 30 mm	2	802M9530
Cannulated Polyaxial Screw, ø9.5 mm x 35 mm	2	802M9535
Cannulated Polyaxial Screw, ø9.5 mm x 40 mm	4	802M9540
Cannulated Polyaxial Screw, ø9.5 mm x 45 mm	4	802M9545
Cannulated Polyaxial Screw, ø9.5 mm x 50 mm	4	802M9550

## Kit Contents (continued)



### Polyaxial Reduction Screws

#### ø4.5 mm Polyaxial Reduction Screws PCR700M0245

DESCRIPTION	QTY	PART NUMBER
Polyaxial Reduction Screw, ø4.5 mm x 30 mm	4	703M4530
Polyaxial Reduction Screw, ø4.5 mm x 35 mm	4	703M4535
Polyaxial Reduction Screw, ø4.5 mm x 40 mm	4	703M4540
Polyaxial Reduction Screw, ø4.5 mm x 45 mm	4	703M4545

#### ø5.0 mm Polyaxial Reduction Screws PCR700M0250

DESCRIPTION	QTY	PART NUMBER
Polyaxial Reduction Screw, ø5.0 mm x 30 mm	4	703M5030
Polyaxial Reduction Screw, ø5.0 mm x 35 mm	4	703M5035
Polyaxial Reduction Screw, ø5.0 mm x 40 mm	4	703M5040
Polyaxial Reduction Screw, ø5.0 mm x 45 mm	4	703M5045
Polyaxial Reduction Screw, ø5.0 mm x 50 mm	4	703M5050

#### ø5.5 mm Polyaxial Reduction Screws PCR700M0255

DESCRIPTION	QTY	PART NUMBER
Polyaxial Reduction Screw, ø5.5 mm x 30 mm	6	703M5530
Polyaxial Reduction Screw, ø5.5 mm x 35 mm	6	703M5535
Polyaxial Reduction Screw, ø5.5 mm x 40 mm	6	703M5540
Polyaxial Reduction Screw, ø5.5 mm x 45 mm	6	703M5545
Polyaxial Reduction Screw, ø5.5 mm x 50 mm	4	703M5550

#### ø6.0 mm Polyaxial Reduction Screws PCR700M0260

DESCRIPTION	QTY	PART NUMBER
Polyaxial Reduction Screw, ø6.0 mm x 30 mm	4	703M6030
Polyaxial Reduction Screw, ø6.0 mm x 35 mm	6	703M6035
Polyaxial Reduction Screw, ø6.0 mm x 40 mm	6	703M6040
Polyaxial Reduction Screw, ø6.0 mm x 45 mm	6	703M6045
Polyaxial Reduction Screw, ø6.0 mm x 50 mm	6	703M6050

#### ø6.5 mm Polyaxial Reduction Screws PCR700M0265

DESCRIPTION	QTY	PART NUMBER
Polyaxial Reduction Screw, ø6.5 mm x 30 mm	4	703M6530
Polyaxial Reduction Screw, ø6.5 mm x 35 mm	6	703M6535
Polyaxial Reduction Screw, ø6.5 mm x 40 mm	6	703M6540
Polyaxial Reduction Screw, ø6.5 mm x 45 mm	6	703M6545
Polyaxial Reduction Screw, ø6.5 mm x 50 mm	6	703M6550

#### ø7.0 mm Polyaxial Reduction Screws PCR700M0270

DESCRIPTION	QTY	PART NUMBER
Polyaxial Reduction Screw, ø7.0 mm x 30 mm	4	703M7030
Polyaxial Reduction Screw, ø7.0 mm x 35 mm	6	703M7035
Polyaxial Reduction Screw, ø7.0 mm x 40 mm	6	703M7040
Polyaxial Reduction Screw, ø7.0 mm x 45 mm	6	703M7045
Polyaxial Reduction Screw, ø7.0 mm x 50 mm	6	703M7050

#### ø7.5 mm Polyaxial Reduction Screws PCR700M0275

DESCRIPTION	QTY	PART NUMBER
Polyaxial Reduction Screw, ø7.5 mm x 30 mm	4	703M7530
Polyaxial Reduction Screw, ø7.5 mm x 35 mm	4	703M7535
Polyaxial Reduction Screw, ø7.5 mm x 40 mm	4	703M7540
Polyaxial Reduction Screw, ø7.5 mm x 45 mm	4	703M7545
Polyaxial Reduction Screw, ø7.5 mm x 50 mm	4	703M7550

#### ø8.5 mm Polyaxial Reduction Screws PCR700M0285

DESCRIPTION	QTY	PART NUMBER
Polyaxial Reduction Screw, ø8.5 mm x 30 mm	2	702M8530
Polyaxial Reduction Screw, ø8.5 mm x 35 mm	2	702M8535
Polyaxial Reduction Screw, ø8.5 mm x 40 mm	2	702M8540
Polyaxial Reduction Screw, ø8.5 mm x 45 mm	2	702M8545
Polyaxial Reduction Screw, ø8.5 mm x 50 mm	2	702M8550





## Uniplanar Screws

### Ø4.5 mm Uniplanar Screws PCR700M0345

DESCRIPTION	QTY	PART NUMBER
Uniplanar Screw, Ø4.5 mm x 25 mm	4	706M4525
Uniplanar Screw, Ø4.5 mm x 30 mm	6	706M4530
Uniplanar Screw, Ø4.5 mm x 35 mm	6	706M4535
Uniplanar Screw, Ø4.5 mm x 40 mm	6	706M4540
Uniplanar Screw, Ø4.5 mm x 45 mm	6	706M4545

### Ø5.0 mm Uniplanar Screws PCR700M0350

DESCRIPTION	QTY	PART NUMBER
Uniplanar Screw, Ø5.0 mm x 30 mm	10	706M5030
Uniplanar Screw, Ø5.0 mm x 35 mm	10	706M5035
Uniplanar Screw, Ø5.0 mm x 40 mm	10	706M5040
Uniplanar Screw, Ø5.0 mm x 45 mm	8	706M5045
Uniplanar Screw, Ø5.0 mm x 50 mm	6	706M5050

### Ø5.5 mm Uniplanar Screws PCR700M0355

DESCRIPTION	QTY	PART NUMBER
Uniplanar Screw, Ø5.5 mm x 30 mm	10	706M5530
Uniplanar Screw, Ø5.5 mm x 35 mm	10	706M5535
Uniplanar Screw, Ø5.5 mm x 40 mm	10	706M5540
Uniplanar Screw, Ø5.5 mm x 45 mm	8	706M5545
Uniplanar Screw, Ø5.5 mm x 50 mm	4	706M5550

### Ø6.0 mm Uniplanar Screws PCR700M0360

DESCRIPTION	QTY	PART NUMBER
Uniplanar Screw, Ø6.0 mm x 30 mm	10	706M6030
Uniplanar Screw, Ø6.0 mm x 35 mm	10	706M6035
Uniplanar Screw, Ø6.0 mm x 40 mm	10	706M6040
Uniplanar Screw, Ø6.0 mm x 45 mm	8	706M6045
Uniplanar Screw, Ø6.0 mm x 50 mm	4	706M6050

### Ø6.5 mm Uniplanar Screws PCR700M0365

DESCRIPTION	QTY	PART NUMBER
Uniplanar Screw, Ø6.5 mm x 30 mm	6	706M6530
Uniplanar Screw, Ø6.5 mm x 35 mm	8	706M6535
Uniplanar Screw, Ø6.5 mm x 40 mm	8	706M6540
Uniplanar Screw, Ø6.5 mm x 45 mm	8	706M6545
Uniplanar Screw, Ø6.5 mm x 50 mm	4	706M6550

### Ø7.5 mm Uniplanar Screws PCR700M0375

DESCRIPTION	QTY	PART NUMBER
Uniplanar Screw, Ø7.5 mm x 30 mm	6	706M7530
Uniplanar Screw, Ø7.5 mm x 35 mm	8	706M7535
Uniplanar Screw, Ø7.5 mm x 40 mm	8	706M7540
Uniplanar Screw, Ø7.5 mm x 45 mm	8	706M7545
Uniplanar Screw, Ø7.5 mm x 50 mm	4	706M7550

## Kit Contents (continued)

### Cannulated Uniplanar Screws

#### ø4.5 mm Cannulated Uniplanar Screws PCR800M0345

DESCRIPTION	QTY	PART NUMBER
Cannulated Uniplanar Screw, ø4.5 mm x 25 mm	4	807M4525
Cannulated Uniplanar Screw, ø4.5 mm x 30 mm	6	807M4530
Cannulated Uniplanar Screw, ø4.5 mm x 35 mm	6	807M4535
Cannulated Uniplanar Screw, ø4.5 mm x 40 mm	6	807M4540
Cannulated Uniplanar Screw, ø4.5 mm x 45 mm	6	807M4545

#### ø5.0 mm Cannulated Uniplanar Screws PCR800M0350

DESCRIPTION	QTY	PART NUMBER
Cannulated Uniplanar Screw, ø5.0 mm x 30 mm	10	807M5030
Cannulated Uniplanar Screw, ø5.0 mm x 35 mm	10	807M5035
Cannulated Uniplanar Screw, ø5.0 mm x 40 mm	10	807M5040
Cannulated Uniplanar Screw, ø5.0 mm x 45 mm	8	807M5045
Cannulated Uniplanar Screw, ø5.0 mm x 50 mm	6	807M5050

#### ø5.5 mm Cannulated Uniplanar Screws PCR800M0355

DESCRIPTION	QTY	PART NUMBER
Cannulated Uniplanar Screw, ø5.5 mm x 30 mm	10	807M5530
Cannulated Uniplanar Screw, ø5.5 mm x 35 mm	10	807M5535
Cannulated Uniplanar Screw, ø5.5 mm x 40 mm	10	807M5540
Cannulated Uniplanar Screw, ø5.5 mm x 45 mm	8	807M5545
Cannulated Uniplanar Screw, ø5.5 mm x 50 mm	4	807M5550

#### ø6.0 mm Cannulated Uniplanar Screws PCR800M0360

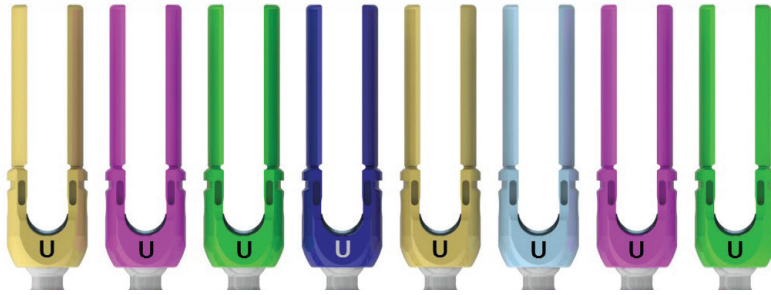
DESCRIPTION	QTY	PART NUMBER
Cannulated Uniplanar Screw, ø6.0 mm x 30 mm	10	807M6030
Cannulated Uniplanar Screw, ø6.0 mm x 35 mm	10	807M6035
Cannulated Uniplanar Screw, ø6.0 mm x 40 mm	10	807M6040
Cannulated Uniplanar Screw, ø6.0 mm x 45 mm	8	807M6045
Cannulated Uniplanar Screw, ø6.0 mm x 50 mm	4	807M6050

#### ø6.5 mm Cannulated Uniplanar Screws PCR800M0365

DESCRIPTION	QTY	PART NUMBER
Cannulated Uniplanar Screw, ø6.5 mm x 30 mm	6	807M6530
Cannulated Uniplanar Screw, ø6.5 mm x 35 mm	8	807M6535
Cannulated Uniplanar Screw, ø6.5 mm x 40 mm	8	807M6540
Cannulated Uniplanar Screw, ø6.5 mm x 45 mm	8	807M6545
Cannulated Uniplanar Screw, ø6.5 mm x 50 mm	4	807M6550

#### ø7.5 mm Cannulated Uniplanar Screws PCR800M0375

DESCRIPTION	QTY	PART NUMBER
Cannulated Uniplanar Screw, ø7.5 mm x 30 mm	6	807M7530
Cannulated Uniplanar Screw, ø7.5 mm x 35 mm	8	807M7535
Cannulated Uniplanar Screw, ø7.5 mm x 40 mm	8	807M7540
Cannulated Uniplanar Screw, ø7.5 mm x 45 mm	8	807M7545
Cannulated Uniplanar Screw, ø7.5 mm x 50 mm	4	807M7550



## Uniplanar Reduction Screws

### ø4.5 mm Uniplanar Reduction Screws PCR700M0445

DESCRIPTION	QTY	PART NUMBER
Uniplanar Reduction Screw, ø4.5 mm x 30 mm	6	707M4530
Uniplanar Reduction Screw, ø4.5 mm x 35 mm	6	707M4535
Uniplanar Reduction Screw, ø4.5 mm x 40 mm	6	707M4540
Uniplanar Reduction Screw, ø4.5 mm x 45 mm	4	707M4545

### ø5.0 mm Uniplanar Reduction Screws PCR700M0450

DESCRIPTION	QTY	PART NUMBER
Uniplanar Reduction Screw, ø5.0 mm x 30 mm	6	707M5030
Uniplanar Reduction Screw, ø5.0 mm x 35 mm	6	707M5035
Uniplanar Reduction Screw, ø5.0 mm x 40 mm	6	707M5040
Uniplanar Reduction Screw, ø5.0 mm x 45 mm	6	707M5045
Uniplanar Reduction Screw, ø5.0 mm x 50 mm	2	707M5050

### ø5.5 mm Uniplanar Reduction Screws PCR700M0455

DESCRIPTION	QTY	PART NUMBER
Uniplanar Reduction Screw, ø5.5 mm x 30 mm	6	707M5530
Uniplanar Reduction Screw, ø5.5 mm x 35 mm	6	707M5535
Uniplanar Reduction Screw, ø5.5 mm x 40 mm	6	707M5540
Uniplanar Reduction Screw, ø5.5 mm x 45 mm	6	707M5545
Uniplanar Reduction Screw, ø5.5 mm x 50 mm	2	707M5550

### ø6.0 mm Uniplanar Reduction Screws PCR700M0460

DESCRIPTION	QTY	PART NUMBER
Uniplanar Reduction Screw, ø6.0 mm x 30 mm	6	707M6030
Uniplanar Reduction Screw, ø6.0 mm x 35 mm	6	707M6035
Uniplanar Reduction Screw, ø6.0 mm x 40 mm	6	707M6040
Uniplanar Reduction Screw, ø6.0 mm x 45 mm	6	707M6045
Uniplanar Reduction Screw, ø6.0 mm x 50 mm	2	707M6050

### ø6.5 mm Uniplanar Reduction Screws PCR700M0465

DESCRIPTION	QTY	PART NUMBER
Uniplanar Reduction Screw, ø6.5 mm x 30 mm	6	707M6530
Uniplanar Reduction Screw, ø6.5 mm x 35 mm	6	707M6535
Uniplanar Reduction Screw, ø6.5 mm x 40 mm	6	707M6540
Uniplanar Reduction Screw, ø6.5 mm x 45 mm	4	707M6545
Uniplanar Reduction Screw, ø6.5 mm x 50 mm	4	707M6550

## Kit Contents (continued)



### Monoaxial Screws

#### ø4.0 mm Monoaxial Screws PCR700M0540

DESCRIPTION	QTY	PART NUMBER
Monoaxial Screw, ø4.0 mm x 20 mm	6	708M4020
Monoaxial Screw, ø4.0 mm x 25 mm	6	708M4025
Monoaxial Screw, ø4.0 mm x 30 mm	6	708M4030
Monoaxial Screw, ø4.0 mm x 35 mm	6	708M4035
Monoaxial Screw, ø4.0 mm x 40 mm	6	708M4040
Monoaxial Screw, ø4.0 mm x 45 mm	6	708M4045

#### ø4.5 mm Monoaxial Screws PCR700M0545

DESCRIPTION	QTY	PART NUMBER
Monoaxial Screw, ø4.5 mm x 20 mm	6	708M4520
Monoaxial Screw, ø4.5 mm x 25 mm	6	708M4525
Monoaxial Screw, ø4.5 mm x 30 mm	6	708M4530
Monoaxial Screw, ø4.5 mm x 35 mm	6	708M4535
Monoaxial Screw, ø4.5 mm x 40 mm	6	708M4540
Monoaxial Screw, ø4.5 mm x 45 mm	6	708M4545

#### ø5.5 mm Monoaxial Screws PCR700M0555

DESCRIPTION	QTY	PART NUMBER
Monoaxial Screw, ø5.5 mm x 20 mm	6	708M5520
Monoaxial Screw, ø5.5 mm x 25 mm	6	708M5525
Monoaxial Screw, ø5.5 mm x 30 mm	8	708M5530
Monoaxial Screw, ø5.5 mm x 35 mm	8	708M5535
Monoaxial Screw, ø5.5 mm x 40 mm	8	708M5540
Monoaxial Screw, ø5.5 mm x 45 mm	8	708M5545

#### ø6.5 mm Monoaxial Screws PCR700M0565

DESCRIPTION	QTY	PART NUMBER
Monoaxial Screw, ø6.5 mm x 35 mm	8	708M6535
Monoaxial Screw, ø6.5 mm x 40 mm	8	708M6540
Monoaxial Screw, ø6.5 mm x 45 mm	8	708M6545
Monoaxial Screw, ø6.5 mm x 50 mm	4	708M6550
Monoaxial Screw, ø6.5 mm x 55 mm	2	708M6555

#### ø7.5 mm Monoaxial Screws PCR700M0575

DESCRIPTION	QTY	PART NUMBER
Monoaxial Screw, ø7.5 mm x 30mm	6	708M7530
Monoaxial Screw, ø7.5 mm x 35 mm	6	708M7535
Monoaxial Screw, ø7.5 mm x 40 mm	6	708M7540
Monoaxial Screw, ø7.5 mm x 45 mm	6	708M7545
Monoaxial Screw, ø7.5 mm x 50 mm	2	708M7550

## Cannulated Monoaxial Screws

### ø4.5 mm Cannulated Monoaxial Screws PCR800M0545

DESCRIPTION	QTY	PART NUMBER
Cannulated Monoaxial Screw, ø4.5 mm x 20 mm	6	809M4520
Cannulated Monoaxial Screw, ø4.5 mm x 25 mm	6	809M4525
Cannulated Monoaxial Screw, ø4.5 mm x 30 mm	6	809M4530
Cannulated Monoaxial Screw, ø4.5 mm x 35 mm	6	809M4535
Cannulated Monoaxial Screw, ø4.5 mm x 40 mm	6	809M4540
Cannulated Monoaxial Screw, ø4.5 mm x 45 mm	6	809M4545

### ø5.5 mm Cannulated Monoaxial Screws PCR800M0555

DESCRIPTION	QTY	PART NUMBER
Cannulated Monoaxial Screw, ø5.5 mm x 20 mm	6	809M5520
Cannulated Monoaxial Screw, ø5.5 mm x 25 mm	6	809M5525
Cannulated Monoaxial Screw, ø5.5 mm x 30 mm	8	809M5530
Cannulated Monoaxial Screw, ø5.5 mm x 35 mm	8	809M5535
Cannulated Monoaxial Screw, ø5.5 mm x 40 mm	8	809M5540
Cannulated Monoaxial Screw, ø5.5 mm x 45 mm	8	809M5545

### ø6.5 mm Cannulated Monoaxial Screws PCR800M0565

DESCRIPTION	QTY	PART NUMBER
Cannulated Monoaxial Screw, ø6.5 mm x 35 mm	8	809M6535
Cannulated Monoaxial Screw, ø6.5 mm x 40 mm	8	809M6540
Cannulated Monoaxial Screw, ø6.5 mm x 45 mm	8	809M6545
Cannulated Monoaxial Screw, ø6.5 mm x 50 mm	4	809M6550
Cannulated Monoaxial Screw, ø6.5 mm x 55 mm	2	809M6555

### ø7.5 mm Cannulated Monoaxial Screws PCR800M0575

DESCRIPTION	QTY	PART NUMBER
Cannulated Monoaxial Screw, ø7.5 mm x 30 mm	6	809M7530
Cannulated Monoaxial Screw, ø7.5 mm x 35 mm	6	809M7535
Cannulated Monoaxial Screw, ø7.5 mm x 40 mm	6	809M7540
Cannulated Monoaxial Screw, ø7.5 mm x 45 mm	6	809M7545
Cannulated Monoaxial Screw, ø7.5 mm x 50 mm	2	809M7550



## Closed Iliac Screws

### Closed Iliac Screws PCR700M0602

DESCRIPTION	QTY	PART NUMBER
Closed Iliac Screw, ø7.5 mm x 70 mm	2	705M7570
Closed Iliac Screw, ø7.5 mm x 80 mm	2	705M7580
Closed Iliac Screw, ø7.5 mm x 90 mm	2	705M7590
Closed Iliac Screw, ø7.5 mm x 100 mm	2	705M7500
Closed Iliac Screw, ø7.5 mm x 110 mm	2	705M7510
Closed Iliac Screw, ø7.5 mm x 120 mm	2	705M7521
Closed Iliac Screw, ø8.5 mm x 70 mm	2	705M8570
Closed Iliac Screw, ø8.5 mm x 80 mm	2	705M8580
Closed Iliac Screw, ø8.5 mm x 90 mm	2	705M8590
Closed Iliac Screw, ø8.5 mm x 100 mm	2	705M8500
Closed Iliac Screw, ø8.5 mm x 110 mm	2	705M8510
Closed Iliac Screw, ø8.5 mm x 120 mm	2	705M8521

DESCRIPTION	QTY	PART NUMBER
Closed Iliac Screw, ø9.5 mm x 70 mm	2	705M9570
Closed Iliac Screw, ø9.5 mm x 80 mm	2	705M9580
Closed Iliac Screw, ø9.5 mm x 90 mm	2	705M9590
Closed Iliac Screw, ø9.5 mm x 100 mm	2	705M9500
Closed Iliac Screw, ø9.5 mm x 110 mm	2	705M9510
Closed Iliac Screw, ø9.5 mm x 120 mm	2	705M9521
Closed Iliac Screw, ø10.5 mm x 70 mm	2	705M1570
Closed Iliac Screw, ø10.5 mm x 80 mm	2	705M1580
Closed Iliac Screw, ø10.5 mm x 90 mm	2	705M1590
Closed Iliac Screw, ø10.5 mm x 100 mm	2	705M1500
Closed Iliac Screw, ø10.5 mm x 110 mm	2	705M1510
Closed Iliac Screw, ø10.5 mm x 120 mm	2	705M1521

## Kit Contents (continued)



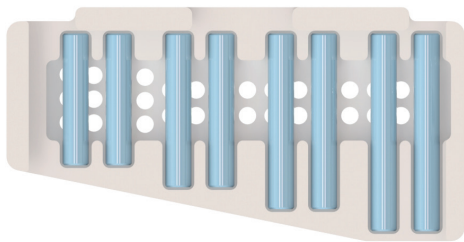
### Open Iliac Screws

#### Open Iliac Screws PCR700M0601

DESCRIPTION	QTY	PART NUMBER
Open Iliac Screw, ø7.5 mm x 70 mm	2	704M7570
Open Iliac Screw, ø7.5 mm x 80 mm	2	704M7580
Open Iliac Screw, ø7.5 mm x 90 mm	2	704M7590
Open Iliac Screw, ø7.5 mm x 100 mm	2	704M7500
Open Iliac Screw, ø7.5 mm x 110 mm	2	704M7510
Open Iliac Screw, ø7.5 mm x 120 mm	2	704M7521
Open Iliac Screw, ø8.5 mm x 70 mm	2	704M8570
Open Iliac Screw, ø8.5 mm x 80 mm	2	704M8580
Open Iliac Screw, ø8.5 mm x 90 mm	2	704M8590
Open Iliac Screw, ø8.5 mm x 100 mm	2	704M8500
Open Iliac Screw, ø8.5 mm x 110 mm	2	704M8510
Open Iliac Screw, ø8.5 mm x 120 mm	2	704M8521
Open Iliac Screw, ø9.5 mm x 70 mm	2	704M9570
Open Iliac Screw, ø9.5 mm x 80 mm	2	704M9580
Open Iliac Screw, ø9.5 mm x 90 mm	2	704M9590
Open Iliac Screw, ø9.5 mm x 100 mm	2	704M9500
Open Iliac Screw, ø9.5 mm x 110 mm	2	704M9510
Open Iliac Screw, ø9.5 mm x 120 mm	2	704M9521
Open Iliac Screw, ø10.5 mm x 70 mm	2	704M1570
Open Iliac Screw, ø10.5 mm x 80 mm	2	704M1580
Open Iliac Screw, ø10.5 mm x 90 mm	2	704M1590
Open Iliac Screw, ø10.5 mm x 100 mm	2	704M1500
Open Iliac Screw, ø10.5 mm x 110 mm	2	704M1510
Open Iliac Screw, ø10.5 mm x 120 mm	2	704M1521

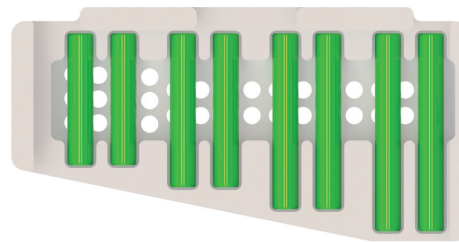
#### Cannulated Open Iliac Screws PCR800M0601

DESCRIPTION	QTY	PART NUMBER
Cannulated Open Iliac Screw Ø7.5mm X 70mm	2	805M7570
Cannulated Open Iliac Screw Ø7.5mm X 80mm	2	805M7580
Cannulated Open Iliac Screw Ø7.5mm X 90mm	2	805M7590
Cannulated Open Iliac Screw Ø7.5mm X 100mm	2	805M7500
Cannulated Open Iliac Screw Ø7.5mm X 110mm	2	805M7510
Cannulated Open Iliac Screw Ø7.5mm X 120mm	2	805M7521
Cannulated Open Iliac Screw Ø8.5mm X 70mm	2	805M8570
Cannulated Open Iliac Screw Ø8.5mm X 80mm	2	805M8580
Cannulated Open Iliac Screw Ø8.5mm X 90mm	2	805M8590
Cannulated Open Iliac Screw Ø8.5mm X 100mm	2	805M8500
Cannulated Open Iliac Screw Ø8.5mm X 110mm	2	805M8510
Cannulated Open Iliac Screw Ø8.5mm X 120mm	2	805M8521
Cannulated Open Iliac Screw Ø9.5mm X 70mm	2	805M9570
Cannulated Open Iliac Screw Ø9.5mm X 80mm	2	805M9580
Cannulated Open Iliac Screw Ø9.5mm X 90mm	2	805M9590
Cannulated Open Iliac Screw Ø9.5mm X 100mm	2	805M9500
Cannulated Open Iliac Screw Ø9.5mm X 110mm	2	805M9510
Cannulated Open Iliac Screw Ø9.5mm X 120mm	2	805M9521
Cannulated Open Iliac Screw Ø10.5mm X 70mm	2	805M1570
Cannulated Open Iliac Screw Ø10.5mm X 80mm	2	805M1580
Cannulated Open Iliac Screw Ø10.5mm X 90mm	2	805M1590
Cannulated Open Iliac Screw Ø10.5mm X 100mm	2	805M1500
Cannulated Open Iliac Screw Ø10.5mm X 110mm	2	805M1510
Cannulated Open Iliac Screw Ø10.5mm X 120mm	2	805M1521



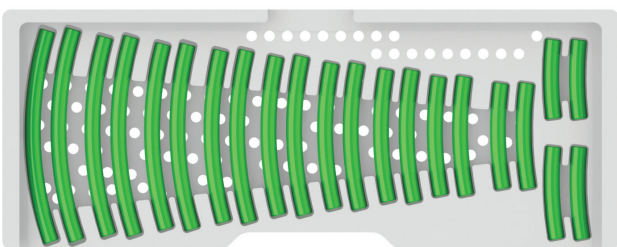
### ø5.5 mm Straight Rods PCR700M1115

DESCRIPTION	QTY	PART NUMBER
ø5.5 x 30 mm, Straight Rod, Ti	2	07.02014.003
ø5.5 x 35 mm, Straight Rod, Ti	2	07.02014.004
ø5.5 x 40 mm, Straight Rod, Ti	2	07.02014.005
ø5.5 x 45 mm, Straight Rod, Ti	2	07.02014.006



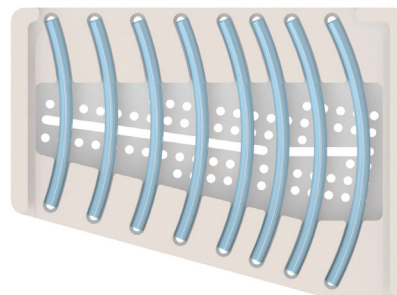
### ø6.0 mm Straight Rods PCR700M1116

DESCRIPTION	QTY	PART NUMBER
ø6.0 x 30 mm, Straight Rod, Ti	2	07.02020.003
ø6.0 x 35 mm, Straight Rod, Ti	2	07.02020.004
ø6.0 x 40 mm, Straight Rod, Ti	2	07.02020.005
ø6.0 x 45 mm, Straight Rod, Ti	2	07.02020.006



### ø6.0 mm Curved Rods PCR700M1216

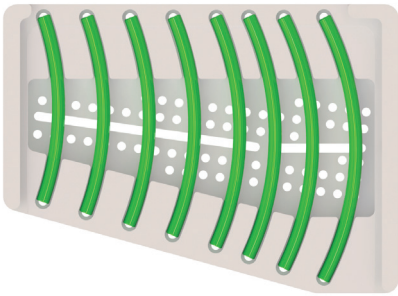
DESCRIPTION	QTY	PART NUMBER
ø6.0 x 30 mm, Curved Rod, Ti	2	07.02021.003
ø6.0 x 35 mm, Curved Rod, Ti	2	07.02021.004
ø6.0 x 40 mm, Curved Rod, Ti	2	07.02021.005
ø6.0 x 45 mm, Curved Rod, Ti	2	07.02021.006
ø6.0 x 50 mm, Curved Rod, Ti	2	07.02021.007
ø6.0 x 55 mm, Curved Rod, Ti	2	07.02021.008
ø6.0 x 60 mm, Curved Rod, Ti	2	07.02021.009
ø6.0 x 65 mm, Curved Rod, Ti	2	07.02021.010
ø6.0 x 70 mm, Curved Rod, Ti	2	07.02021.011
ø6.0 x 75 mm, Curved Rod, Ti	2	07.02021.012
ø6.0 x 80 mm, Curved Rod, Ti	2	07.02021.013



### ø5.5 mm Intermediate Curved Rods PCR700M1225

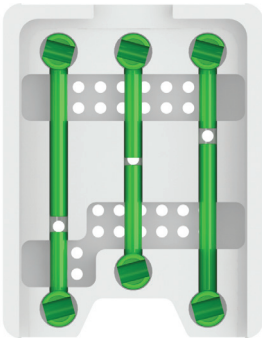
DESCRIPTION	QTY	PART NUMBER
ø5.5 x 85 mm, Curved Rod, Ti	4	07.02015.014
ø5.5 x 90 mm, Curved Rod, Ti	4	07.02015.015
ø5.5 x 95 mm, Curved Rod, Ti	4	07.02015.016
ø5.5 x 100 mm, Curved Rod, Ti	4	07.02015.017
ø5.5 x 105 mm, Curved Rod, Ti	4	07.02015.018
ø5.5 x 110 mm, Curved Rod, Ti	4	07.02015.019
ø5.5 x 115 mm, Curved Rod, Ti	4	07.02015.020
ø5.5 x 120 mm, Curved Rod, Ti	4	07.02015.021

## Kit Contents (continued)



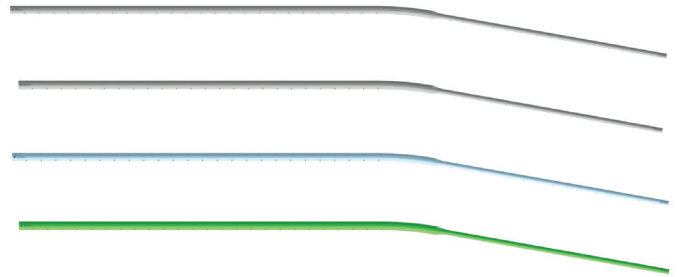
### ø6.0 mm Intermediate Curved Rods PCR700M1226

DESCRIPTION	QTY	PART NUMBER
ø6.0 x 85 mm, Curved Rod, Ti	2	07.02021.014
ø6.0 x 90 mm, Curved Rod, Ti	2	07.02021.015
ø6.0 x 95 mm, Curved Rod, Ti	2	07.02021.016
ø6.0 x 100 mm, Curved Rod, Ti	2	07.02021.017
ø6.0 x 105 mm, Curved Rod, Ti	2	07.02021.018
ø6.0 x 110 mm, Curved Rod, Ti	2	07.02021.019
ø6.0 x 115 mm, Curved Rod, Ti	2	07.02021.020
ø6.0 x 120 mm, Curved Rod, Ti	2	07.02021.021



### Open 15° Lateral Offset Connectors PCR700M3151

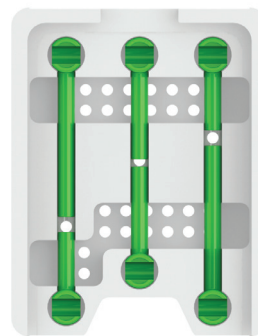
DESCRIPTION	QTY	PART NUMBER
Lateral Offset Connector, Open, L15°, 20 mm	1	07.02025.025
Lateral Offset Connector, Open, L15°, 30 mm	1	07.02025.027
Lateral Offset Connector, Open, L15°, 50 mm	1	07.02025.031
Lateral Offset Connector, Open, R15°, 20 mm	1	07.02025.047
Lateral Offset Connector, Open, R15°, 30 mm	1	07.02025.049
Lateral Offset Connector, Open, R15°, 50 mm	1	07.02025.053



### Transition Rods

\*Optional implants not included in a kit

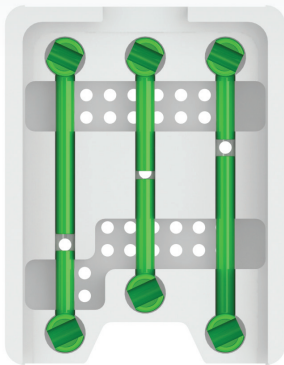
DESCRIPTION	PART NUMBER
Transition Rod, ø3.5-ø5.5 CoCr, 300 mm	726M1300
Transition Rod, ø3.5-ø5.5 CoCr, 450 mm	726M1450
Transition Rod, ø3.5-ø5.5 CoCr, 510 mm	726M1510
Transition Rod, ø3.5-ø5.5 CoCr, 600 mm	726M1600
Transition Rod, ø3.5-ø6.0 CoCr, 300 mm	726M5300
Transition Rod, ø3.5-ø6.0 CoCr, 450 mm	726M5450
Transition Rod, ø3.5-ø6.0 CoCr, 510 mm	726M5510
Transition Rod, ø3.5-ø6.0 CoCr, 600 mm	726M5600
Transition Rod, ø3.5-ø5.5 Ti, 300 mm	726M2300
Transition Rod, ø3.5-ø5.5 Ti, 450 mm	726M2450
Transition Rod, ø3.5-ø5.5 Ti, 510 mm	726M2510
Transition Rod, ø3.5-ø5.5 Ti, 600 mm	726M2600
Transition Rod, ø3.5-ø6.0 Ti, 300 mm	726M6300
Transition Rod, ø3.5-ø6.0 Ti, 450 mm	726M6450
Transition Rod, ø3.5-ø6.0 Ti, 510 mm	726M6510
Transition Rod, ø3.5-ø6.0 Ti, 600 mm	726M6600



### Open Straight Lateral Offset Connectors PCR700M3001

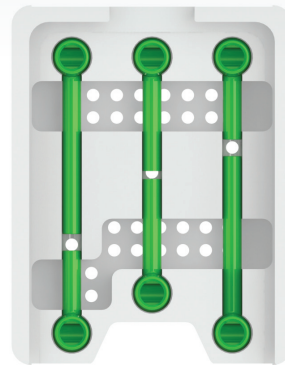
DESCRIPTION	QTY	PART NUMBER
Lateral Offset Connector, Open, S00°, 20 mm	2	07.02025.003
Lateral Offset Connector, Open, S00°, 30 mm	2	07.02025.005
Lateral Offset Connector, Open, S00°, 50 mm	2	07.02025.009





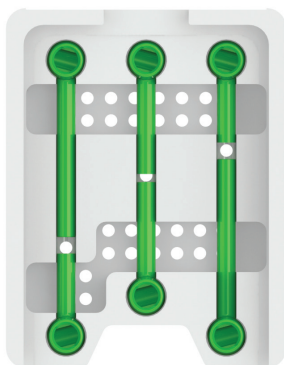
### Open 25° Lateral Offset Connectors PCR700M3251

DESCRIPTION	QTY	PART NUMBER
Lateral Offset Connector, Open, L25°, 20 mm	1	07.02025.069
Lateral Offset Connector, Open, L25°, 30 mm	1	07.02025.071
Lateral Offset Connector, Open, L25°, 50 mm	1	07.02025.075
Lateral Offset Connector, Open, R25°, 20 mm	1	07.02025.091
Lateral Offset Connector, Open, R25°, 30 mm	1	07.02025.093
Lateral Offset Connector, Open, R25°, 50 mm	1	07.02025.097



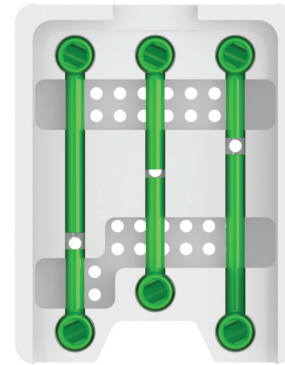
### Closed Straight Lateral Offset Connectors PCR700M3002

DESCRIPTION	QTY	PART NUMBER
Lateral Offset Connector, Closed, S00°, 20 mm	2	07.02026.003
Lateral Offset Connector, Closed, S00°, 30 mm	2	07.02026.005
Lateral Offset Connector, Closed, S00°, 50 mm	2	07.02026.009



### Closed 15° Lateral Offset Connectors PCR700M3152

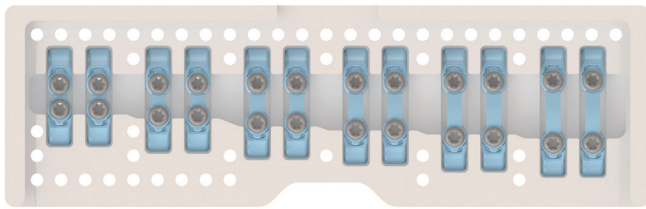
DESCRIPTION	QTY	PART NUMBER
Lateral Offset Connector, Closed, L15°, 20 mm	1	07.02026.025
Lateral Offset Connector, Closed, L15°, 30 mm	1	07.02026.027
Lateral Offset Connector, Closed, L15°, 50 mm	1	07.02026.031
Lateral Offset Connector, Closed, R15°, 20 mm	1	07.02026.047
Lateral Offset Connector, Closed, R15°, 30 mm	1	07.02026.049
Lateral Offset Connector, Closed, R15°, 50 mm	1	07.02026.053



### Closed 25° Lateral Offset Connectors PCR700M3252

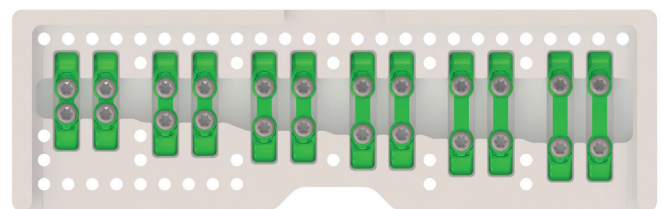
DESCRIPTION	QTY	PART NUMBER
Lateral Offset Connector, Closed, L25°, 20 mm	1	07.02026.069
Lateral Offset Connector, Closed, L25°, 30 mm	1	07.02026.071
Lateral Offset Connector, Closed, L25°, 50 mm	1	07.02026.075
Lateral Offset Connector, Closed, R25°, 20 mm	1	07.02026.091
Lateral Offset Connector, Closed, R25°, 30 mm	1	07.02026.093
Lateral Offset Connector, Closed, R25°, 50 mm	1	07.02026.097

## Kit Contents (continued)



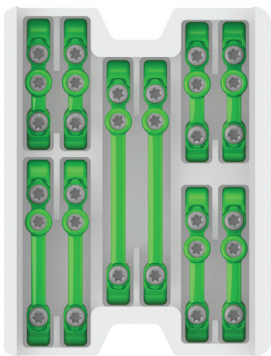
### ø5.5 mm Fixed Transverse Connectors PCR700M4105

DESCRIPTION	QTY	PART NUMBER
Transverse Connector, Fixed, 21 mm x 5.5 mm	2	07.02048.001
Transverse Connector, Fixed, 23 mm x 5.5 mm	2	07.02048.002
Transverse Connector, Fixed, 25 mm x 5.5 mm	2	07.02048.003
Transverse Connector, Fixed, 27 mm x 5.5 mm	2	07.02048.004
Transverse Connector, Fixed, 29 mm x 5.5 mm	2	07.02048.005
Transverse Connector, Fixed, 31 mm x 5.5 mm	2	07.02048.006



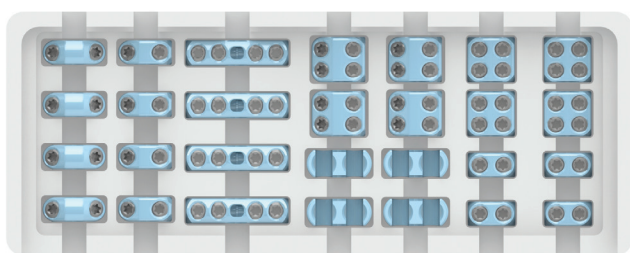
### ø6.0 mm Fixed Transverse Connectors PCR700M4106

DESCRIPTION	QTY	PART NUMBER
Transverse Connector, Fixed, 21 mm x 6.0 mm	2	07.02048.017
Transverse Connector, Fixed, 23 mm x 6.0 mm	2	07.02048.018
Transverse Connector, Fixed, 25 mm x 6.0 mm	2	07.02048.019
Transverse Connector, Fixed, 27 mm x 6.0 mm	2	07.02048.020
Transverse Connector, Fixed, 29 mm x 6.0 mm	2	07.02048.021
Transverse Connector, Fixed, 31 mm x 6.0 mm	2	07.02048.022



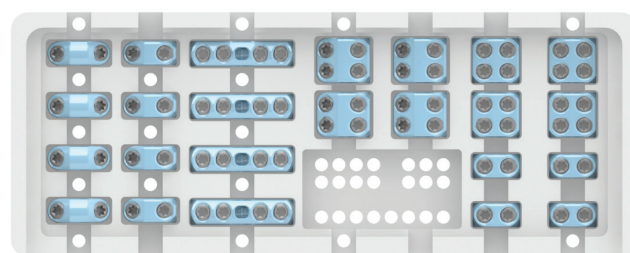
### ø6.0 mm Adjustable Transverse Connectors PCR700M4206

DESCRIPTION	QTY	PART NUMBER
Transverse Connector, Adjustable, 33-36 mm wide x 6.0 mm	2	07.02030.006
Transverse Connector, Adjustable, 36-41 mm wide x 6.0 mm	2	07.02030.007
Transverse Connector, Adjustable, 41-51 mm wide x 6.0 mm	2	07.02030.008
Transverse Connector, Adjustable, 51-70 mm wide x 6.0 mm	2	07.02030.009
Transverse Connector, Adjustable, 70-90 mm wide x 6.0 mm	2	07.02030.010



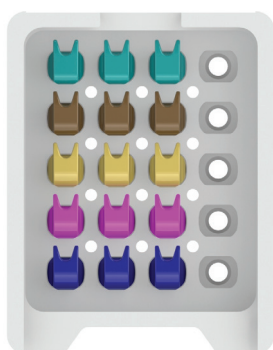
### ø5.5-6.0 mm Rod Connectors PCR700M5056

DESCRIPTION	QTY	PART NUMBER
Rod Connector, Lateral, Open, 2 Screw, ø5.5-6.0 mm x 5.5-6.0 mm	4	07.02027.001
Rod Connector, Lateral, Closed, 4 Screw, ø5.5-6.0 mm x 5.5-6.0 mm	4	07.02028.001
Rod Connector, Axial, Closed, ø5.5-6.0 mm x 5.5-6.0 mm	4	07.02029.001
Rod Connector, Lateral, Closed, 2 Screw, ø5.5-6.0 mm x 5.5-6.0 mm	4	07.02032.001
Rod Connector, Lateral, Hybrid, 2 Screw, ø5.5-6.0 mm x 5.5-6.0 mm	4	07.02033.001
Rod Connector, Lateral, Hybrid, 4 Screw, ø5.5-6.0 mm x 5.5-6.0 mm	4	07.02034.001
Rod Connector, Lateral, Channel	4	07.02035.001



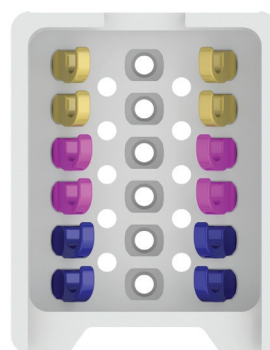
### ø3.5 mm x ø5.5-6.0 mm Rod Connectors PCR700M5035

DESCRIPTION	QTY	PART NUMBER
Rod Connector, Lateral, Open, 2 Screw, ø3.5 mm x 5.5-6.0 mm	4	07.02027.002
Rod Connector, Lateral, Closed, 4 Screw, ø3.5 mm x 5.5-6.0 mm	4	07.02028.002
Rod Connector, Axial, Closed, ø3.5 mm x 5.5-6.0 mm	4	07.02029.002
Rod Connector, Lateral, Closed, 2 Screw, ø3.5 mm x 5.5-6.0 mm	4	07.02032.002
Rod Connector, Lateral, Hybrid, 2 Screw, ø3.5 mm x 5.5-6.0 mm	4	07.02033.002
Rod Connector, Lateral, Hybrid, 4 Screw, ø3.5 mm x 5.5-6.0 mm	4	07.02034.002



### Pedicle Hooks PCR700M6001

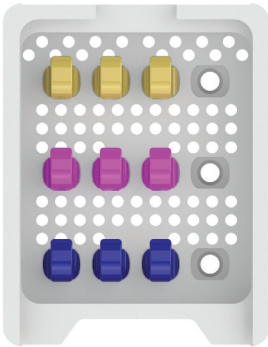
DESCRIPTION	QTY	PART NUMBER
Pedicle Hook, XXS	3	720M0140
Pedicle Hook, XS	3	720M0150
Pedicle Hook, Small	3	720M0160
Pedicle Hook, Medium	3	720M0175
Pedicle Hook, Large	3	720M0190



### Angled Hooks PCR700M6002

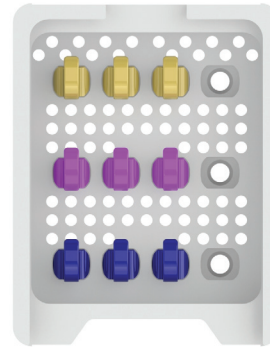
DESCRIPTION	QTY	PART NUMBER
Left Angled Hook, Small	2	720M3060
Left Angled Hook, Medium	2	720M3075
Left Angled Hook, Large	2	720M3090
Right Angled Hook, Small	2	720M3160
Right Angled Hook, Medium	2	720M3175
Right Angled Hook, Large	2	720M3190

## Kit Contents (continued)



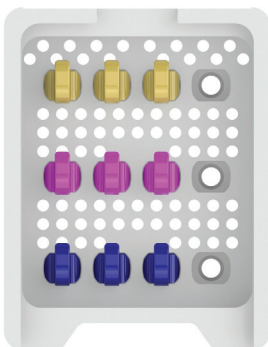
### Laminar Hooks PCR700M6003

DESCRIPTION	QTY	PART NUMBER
Laminar Hook, Small	3	720M0460
Laminar Hook, Medium	3	720M0475
Laminar Hook, Large	3	720M0490



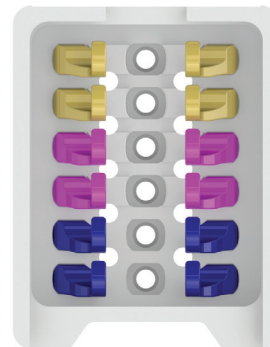
### Narrow Laminar Hooks PCR700M6004

DESCRIPTION	QTY	PART NUMBER
Narrow Laminar Hook, Small	3	720M0560
Narrow Laminar Hook, Medium	3	720M0575
Narrow Laminar Hook, Large	3	720M0590



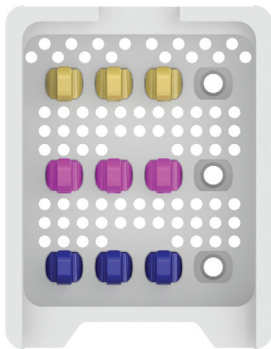
### Narrow Reduced Laminar Hooks PCR700M6005

DESCRIPTION	QTY	PART NUMBER
Narrow Reduced Laminar Hook, Small	3	720M0660
Narrow Reduced Laminar Hook, Medium	3	720M0675
Narrow Reduced Laminar Hook, Large	3	720M0690



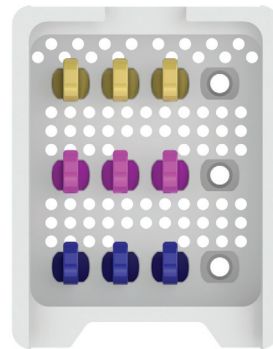
### Offset Hooks PCR700M6006

DESCRIPTION	QTY	PART NUMBER
Left Offset Hook, Small	2	720M2060
Left Offset Hook, Medium	2	720M2075
Left Offset Hook, Large	2	720M2090
Right Offset Hook, Small	2	720M2160
Right Offset Hook, Medium	2	720M2175
Right Offset Hook, Large	2	720M2190



**Angled Blade Hooks  
PCR700M6007**

DESCRIPTION	QTY	PART NUMBER
Angled Blade Hook, Small	3	720M0960
Angled Blade Hook, Medium	3	720M0975
Angled Blade Hook, Large	3	720M0990



**Extended Laminar Hooks  
PCR700M6008**

DESCRIPTION	QTY	PART NUMBER
Extended Laminar Hook, Small	3	720M1060
Extended Laminar Hook, Medium	3	720M1075
Extended Laminar Hook, Large	3	720M1090



**Transverse Process Hooks  
PCR700M6009**

DESCRIPTION	QTY	PART NUMBER
Left Transverse Process Hook, Small	2	720M7060
Left Transverse Process Hook, Medium	2	720M7075
Left Transverse Process Hook, Large	2	720M7090
Right Transverse Process Hook, Small	2	720M7160
Right Transverse Process Hook, Medium	2	720M7175
Right Transverse Process Hook, Large	2	720M7190

## Quick Reference Guide to Implant Caddies

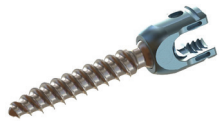
DESCRIPTION	PART NUMBER
Vital Auxiliary Screws – 4.5/8.5*	PCR700M4995
ø4.0 mm Polyaxial Screws	PCR700M0140
ø4.5 mm Polyaxial Screws	PCR700M0145
ø5.0 mm Polyaxial Screws	PCR700M0150
ø5.5 mm Polyaxial Screws	PCR700M0155
ø6.0 mm Polyaxial Screws	PCR700M0160
ø6.5 mm Polyaxial Screws	PCR700M0165
ø7.0 mm Polyaxial Screws	PCR700M0170
ø7.5 mm Polyaxial Screws	PCR700M0175
ø8.5 mm Polyaxial Screws	PCR700M0185
ø9.5 mm Polyaxial Screws	PCR700M0195
ø10.5 mm Polyaxial Screws	PCR700M0115
ø4.5 mm Polyaxial Reduction Screws	PCR700M0245
ø5.0 mm Polyaxial Reduction Screws	PCR700M0250
ø5.5 mm Polyaxial Reduction Screws	PCR700M0255
ø6.0 mm Polyaxial Reduction Screws	PCR700M0260
ø6.5 mm Polyaxial Reduction Screws	PCR700M0265
ø7.0 mm Polyaxial Reduction Screws	PCR700M0270
ø7.5 mm Polyaxial Reduction Screws	PCR700M0275
ø8.5 mm Polyaxial Reduction Screws	PCR700M0285
ø4.5 mm Uniplanar Screws	PCR700M0345
ø5.0 mm Uniplanar Screws	PCR700M0350
ø5.5 mm Uniplanar Screws	PCR700M0355
ø6.0 mm Uniplanar Screws	PCR700M0360
ø6.5 mm Uniplanar Screws	PCR700M0365
ø7.5 mm Uniplanar Screws	PCR700M0375
ø4.5 mm Uniplanar Reduction Screws	PCR700M0445
ø5.0 mm Uniplanar Reduction Screws	PCR700M0450
ø5.5 mm Uniplanar Reduction Screws	PCR700M0455
ø6.0 mm Uniplanar Reduction Screws	PCR700M0460
ø6.5 mm Uniplanar Reduction Screws	PCR700M0465
ø4.0 mm Monoaxial Screws	PCR700M0540
ø4.5 mm Monoaxial Screws	PCR700M0545
ø5.5 mm Monoaxial Screws	PCR700M0555
ø6.5 mm Monoaxial Screws	PCR700M0565
ø7.5 mm Monoaxial Screws	PCR700M0575
ø4.5 mm Cannulated Polyaxial Screws	PCR800M0145
ø5.0 mm Cannulated Polyaxial Screws	PCR800M0150
ø5.5 mm Cannulated Polyaxial Screws	PCR800M0155
ø6.0 mm Cannulated Polyaxial Screws	PCR800M0160
ø6.5 mm Cannulated Polyaxial Screws	PCR800M0165
ø7.0 mm Cannulated Polyaxial Screws	PCR800M0170
ø7.5 mm Cannulated Polyaxial Screws	PCR800M0175

\*Independent caddy does not fit in any kit

DESCRIPTION	PART NUMBER
ø8.5 mm Cannulated Polyaxial Screws	PCR800M0185
ø9.5 mm Cannulated Polyaxial Screws	PCR800M0195
ø4.5 mm Cannulated Uniplanar Screws	PCR800M0345
ø5.0 mm Cannulated Uniplanar Screws	PCR800M0350
ø5.5 mm Cannulated Uniplanar Screws	PCR800M0355
ø6.0 mm Cannulated Uniplanar Screws	PCR800M0360
ø6.5 mm Cannulated Uniplanar Screws	PCR800M0365
ø7.5 mm Cannulated Uniplanar Screws	PCR800M0375
ø4.5 mm Cannulated Monoaxial Screws	PCR800M0545
ø5.5 mm Cannulated Monoaxial Screws	PCR800M0555
ø6.5 mm Cannulated Monoaxial Screws	PCR800M0565
ø7.5 mm Cannulated Monoaxial Screws	PCR800M0575
Cannulated Open Iliac Screws	PCR800M0601
Open Iliac Screws	PCR700M0601
Closed Iliac Screws	PCR700M0602
ø5.5 mm Straight Rods	PCR700M1115
ø6.0 mm Straight Rods	PCR700M1116
ø6.0 mm Curved Rods	PCR700M1216
ø5.5 mm Intermediate Curved Rods	PCR700M1225
ø6.0 mm Intermediate Curved Rods	PCR700M1226
Open Straight Lateral Offset Connectors	PCR700M3001
Open 15° Lateral Offset Connectors	PCR700M3151
Open 25° Lateral Offset Connectors	PCR700M3251
Closed Straight Lateral Offset Connectors	PCR700M3002
Closed 15° Lateral Offset Connectors	PCR700M3152
Closed 25° Lateral Offset Connectors	PCR700M3252
ø5.5 mm Fixed Transverse Connectors	PCR700M4105
ø6.0 mm Fixed Transverse Connectors	PCR700M4106
ø5.5 mm x ø6.0 mm Fixed Transverse Connectors	PCR700M4156
ø6.0 mm Adjustable Transverse Connectors	PCR700M4206
ø5.5 mm x ø6.0 mm Adjustable Transverse Connectors	PCR700M4256
ø5.5-6.0 mm Rod Connectors	PCR700M5056
ø3.5 mm x ø5.5-6.0 mm Rod Connectors	PCR700M5035
Pedicle Hooks	PCR700M6001
Angled Hooks	PCR700M6002
Laminar Hooks	PCR700M6003
Narrow Laminar Hooks	PCR700M6004
Narrow Reduced Laminar Hooks	PCR700M6005
Offset Hooks	PCR700M6006
Angled Blade Hooks	PCR700M6007
Extended Laminar Hooks	PCR700M6008
Transverse Process Hooks	PCR700M6009

# Implants Visual Guide

## Screws



Polyaxial Screws  
(4.0 mm–10.5 mm)



Polyaxial Reduction Screws  
(4.5 mm–8.5 mm)



Closed Polyaxial Iliac Screws  
(7.5 mm–10.5 mm)



Polyaxial Iliac Screws  
(7.5 mm–10.5 mm)



Cannulated Polyaxial Screws  
(4.5 mm - 9.5 mm)



Cannulated Uniplanar Screws  
(4.5 mm - 7.5 mm)



Cannulated Monoaxial Screws  
(4.5 mm - 7.5 mm)



Cannulated Polyaxial Iliac Screws  
(7.5 mm - 10.5 mm)



Uniplanar Screws  
(4.5 mm–7.5 mm)



Uniplanar Reduction Screws  
(4.5 mm–6.5 mm)



Monoaxial Screw  
(4.0 mm–7.5 mm)

## Closure Tops



Closure Tops, Torque Limit  
07.02010.001



Closure Top, Shear Off  
07.02011.001

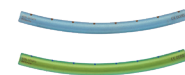
## Rods



5.5mm (light blue)/6mm (green), Rod, Ti Alloy, Straight  
(30 mm–510 mm)



5.5mm / 6mm Rod, Cobalt Chrome, Straight  
(300 mm–510 mm)



5.5mm / 6mm, Rod, Ti Alloy,  
Curved (30 mm–120 mm)



Ti Alloy, 3.5 mm to 5.5 mm (light blue)  
Ti Alloy, 3.5 mm to 6.0 mm (green)  
Cobalt Chrome, 3.5 mm to 5.5 mm  
Cobalt Chrome, 3.5 mm to 6.0 mm  
(300 mm-600 mm)

## Hooks

Hook styles are color-coded by throat size. All hooks are available in titanium.

### BLADE SIZES

Narrow, 5.0 mm
Wide, 7.3 mm
Pedicle, 8.4 mm
Transverse Process, 9.0 mm



### THROAT SIZES

THROAT SIZES	COLOR CODING
XX Small, 4.0 mm*	Teal
X Small, 5.0 mm*	Bronze
Small, 6.0 mm	Gold
Medium, 7.5 mm	Magenta
Large, 9.0 mm	Dark Blue



PEDICLE HOOK	PART NUMBER
XX Small, 4.0 mm	720M0140
X Small, 5.0 mm	720M0150
Small, 6.0 mm	720M0160
Medium, 7.5 mm	720M0175
Large, 9.0 mm	720M0190



LAMINAR HOOK	PART NUMBER
Small, 6.0 mm	720M0460
Medium, 7.5 mm	720M0475
Large, 9.0 mm	720M0490



NARROW REDUCED LAMINAR HOOK	PART NUMBER
Small, 6.0 mm	720M0660
Medium, 7.5 mm	720M0675
Large, 9.0 mm	720M0690



OFFSET HOOK	PART NUMBER
Left, Small, 6.0 mm	720M2060
Left, Medium, 7.5 mm	720M2075
Left, Large, 9.0 mm	720M2090



Right, Small, 6.0 mm	720M2160
Right, Medium, 7.5 mm	720M2175
Right, Large, 9.0 mm	720M2190



ANGLED BLADE HOOK	PART NUMBER
Small, 6.0 mm	720M0960
Medium, 7.5 mm	720M0975
Large, 9.0 mm	720M0990

\*Pedicle hook only



ANGLED HOOK	PART NUMBER
Left, Small, 6.0 mm	720M3060
Left, Medium, 7.5 mm	720M3075
Left, Large, 9.0 mm	720M3090



Right, Small, 6.0 mm	720M3160
Right, Medium, 7.5 mm	720M3175
Right, Large, 9.0 mm	720M3190



NARROW LAMINAR HOOK	PART NUMBER
Small, 6.0 mm	720M0560
Medium, 7.5 mm	720M0575
Large, 9.0 mm	720M0590



EXTENDED LAMINAR HOOK	PART NUMBER
Small, 6.0 mm	720M1060
Medium, 7.5 mm	720M1075
Large, 9.0 mm	720M1090



TRANSVERSE PROCESS HOOK	PART NUMBER
Left, Small, 6.0 mm	720M7060
Left, Medium, 7.5 mm	720M7075
Left, Large, 9.0 mm	720M7090



Right, Small, 6.0 mm	720M7160
Right, Medium, 7.5 mm	720M7175
Right, Large, 9.0 mm	720M7190



## Implants Visual Guide *(continued)*

### Connectors



Lateral Offset Connector, Open  
(20 mm–50 mm)  
07.02025.XXX



Lateral Offset Connector, Closed  
(20 mm–50 mm)  
07.02026.XXX



Rod Connector, Lateral, Open  
07.02027.001 (5.5/6 mm)  
07.02027.002 (3.5 mm)



Rod Connector, Lateral, Closed  
07.02028.001 (5.5/6 mm)  
07.02028.002 (3.5 mm)



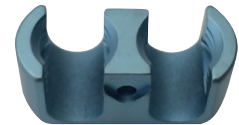
Rod Connector, Axial, Closed  
07.02029.001 (5.5/6 mm)  
07.02029.002 (3.5 mm)



Rod Connector, Lateral, Closed  
07.02032.001 (5.5/6 mm)  
07.02032.002 (3. mm)



Rod Connector, Lateral, Hybrid  
07.02033.001 (2 screw 5.5/6 mm)  
07.02033.002 (2 screw 3.5 mm)  
07.02034.001 (4 screw 5.5/6 mm)  
07.02034.002 (4 screw 3.5 mm)



Rod Connector, Lateral, Channel  
07.02035.001



Adjustable Transverse Connector  
(32 mm–90 mm)  
07.02030.001-005 (5.5 mm)  
07.02030.006-010 (6 mm)



Transverse Connector, Fixed  
(21 mm–31 mm)  
07.02048.001-006 (5.5 mm)  
07.02048.017-022 (6 mm)

## Pedicle Preparation



Awl	PART NUMBER
	07.02076.001



Pilot Drill, 2.4 mm	PART NUMBER
	731M0040



Standard Drill, 2.0 mm	PART NUMBER
	731M0021



Blunt-tip Reamer, 3.0 mm	PART NUMBER
	731M0031



Pedicle Probes	PART NUMBER
Pedicle Probe - Thoracic Straight	730M1005
Pedicle Probe - Thoracic Curved	730M1006
Pedicle Probe - Lumbar Straight	730M1001
Pedicle Probe - Lumbar Curved Lenke	730M1004
Pedicle Probe - Iliac	730M1007



Ball Tip Probe, Standard — Dual-Ended	PART NUMBER
	07.02117.001



Ball Tip Probe, Single-Ended, Stiff — Standard	PART NUMBER
	07.02115.001



Taps	PART NUMBER
3.5 mm (Grey)	730M3035
4.5 mm (Magenta)	730M3045
5.5 mm (Dark Blue)	730M3055
6.5 mm (Light Blue)	730M3065
7.5 mm (Green)	730M3075
8.5 mm (Gold)	730M3085
4.5 mm (Magenta), Cannulated	735M0145
5.5 mm (Dark Blue), Cannulated	735M0155
6.5 mm (Light Blue), Cannulated	735M0165
7.5 mm (Green), Cannulated	735M0175
8.5 mm (Gold), Cannulated	735M0185



Taps (Power)	PART NUMBER
4.5 mm (Magenta), Non-cannulated, Z-Connect	731M0145
5.5 mm (Dark Blue), Non-cannulated, Z-Connect	731M0155
6.5 mm (Light Blue), Non-cannulated, Z-Connect	731M0165
7.5 mm (Green), Non-cannulated, Z-Connect	731M0175



Iliac Taps	PART NUMBER
6.5 mm (Light Blue) Cannulated Iliac Tap	730M5065
7.5 mm (Green) Cannulated Tap Iliac Tap	730M5075
8.5 mm (Gold) Cannulated Tap Iliac Tap	730M5085
9.5 mm (Light Blue) Cannulated Iliac Tap	730M5095

**Pedicle Preparation (continued)**



Iliac Taps (Power)	PART NUMBER
6.5 mm (Light Blue) Cannulated, Z-Connect	731M0265
7.5 mm (Green) Cannulated, Z-Connect	731M0275
8.5 mm (Gold) Cannulated, Z-Connect	731M0285
9.5 mm (Light Blue) Cannulated, Z-Connect	731M0295



Screwdriver, Standard - Non-cannulated	PART NUMBER
	07.02054.001



Screwdriver, Standard - Cannulated	PART NUMBER
	730M0060



Screwdriver, Standard - Reduction	PART NUMBER
	07.02058.001



Screwdriver, Z-Connect Cannulated, Standard, Non-locking	PART NUMBER
	731M0000



Screwdriver, Z-Connect Cannulated, Short, Non-locking	PART NUMBER
	731M0001



Screwdriver, Z-Connect, Stab-N-Grab	PART NUMBER
	731M0010



Screwdriver Sleeve, Standard	PART NUMBER
	07.02131.001



Screwdriver Sleeve, Reduction	PART NUMBER
	07.02131.002



Standard Straight - Ratcheting	PART NUMBER
	07.02051.001



Straight - Ratcheting, Z-Connect	PART NUMBER
	731M9002

## Instruments (continued)

### Pedicle Preparation (continued)



**T-handle - Ratcheting**

PART NUMBER  
07.02052.001



**Palm - Ratcheting**

PART NUMBER  
07.02105.001



**Standard Head Height Adjuster**

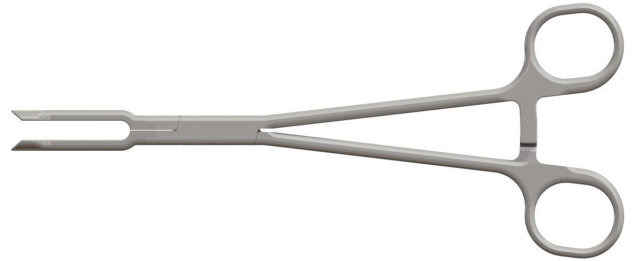
PART NUMBER  
07.02060.001



**Fixed Screw Height Adjuster**

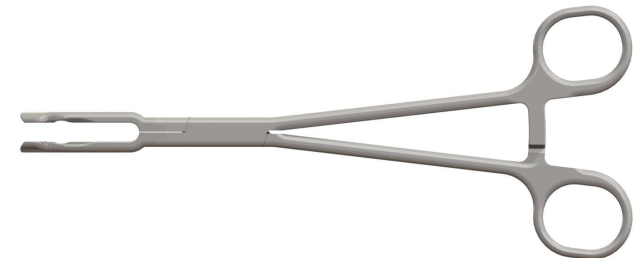
PART NUMBER  
730M0003

### Hook Prep and Insertion



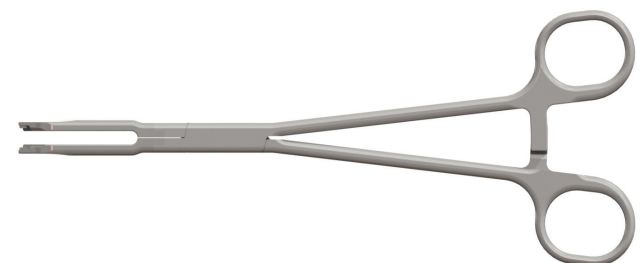
**Vertical Hook Holder**

PART NUMBER  
730M0027



**Angled Hook Holder**

PART NUMBER  
730M0028



**Side Hook Holder**

PART NUMBER  
730M0029



**Hook Impactor**

PART NUMBER  
730M0030

## Hook Prep and Insertion (continued)



**Pedicle Hook Starter** PART NUMBER  
730M0031



**Wide Lamina Hook Starter** PART NUMBER  
730M0032



**Narrow Lamina Hook Starter** PART NUMBER  
730M0034



**Thoracic Hook Starter** PART NUMBER  
730M0035



**Transverse Process Hook Starter** PART NUMBER  
730M0052

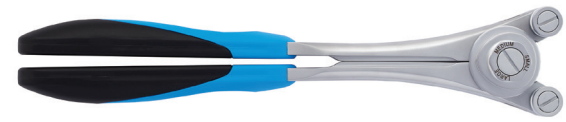
## Rod Contouring and Insertion



**Bone Planer** PART NUMBER  
730M0004



**Rod Templates** PART NUMBER  
250 mm 07.02099.002  
510 mm 07.02099.004



**French Rod Bender** PART NUMBER  
07.02092.001



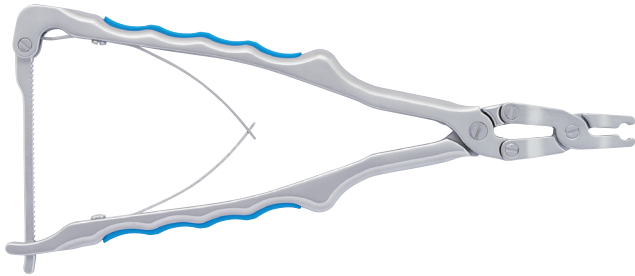
**Rod Holder** PART NUMBER  
07.02064.001



**Vise Grips** PART NUMBER  
07.02104.001

## Instruments (continued)

### Rod Contouring and Insertion (continued)



**Rod Gripper** PART NUMBER  
07.02100.001



**Hex End Rod Rotation Tool** PART NUMBER  
07.02127.001

### Closure Top Insertion



**T27 Provisional Driver (Male) - Reducer (Long)** PART NUMBER  
730M0019



**T27 Provisional Driver (Male) - Dual-ended** PART NUMBER  
730M0018



**Shear-off Closure Top Provisional Driver** PART NUMBER  
730M0050

### Rod Persuasion



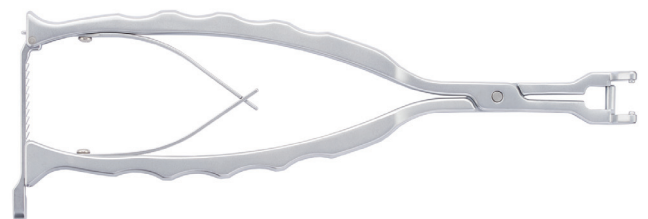
**Angled Rod Pusher** PART NUMBER  
07.02101.001



**Rod Manipulator** PART NUMBER  
730M0015



**Tube Rod Pusher** PART NUMBER  
730M0014



**Rod Rockers** PART NUMBER  
Standard 07.02093.001  
Rod Rocker, Long 730M0037

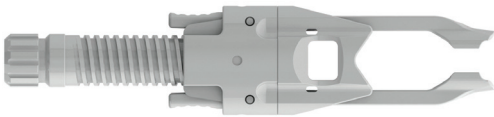


**Single-action Rod Reducers** PART NUMBER  
Standard 730M0026

## Rod Persuasion (continued)



<b>Tower Reducer</b>	PART NUMBER
	730M0021



<b>Rocket™ Threaded Rod Reducer</b>	PART NUMBER
	730M0024



<b>Quick Connect Adapter – Long</b>	PART NUMBER
	730M0005



<b>Quick Connect Adapter – Short</b>	PART NUMBER
	730M0023



<b>Reducer T-handle</b>	PART NUMBER
	730M0022

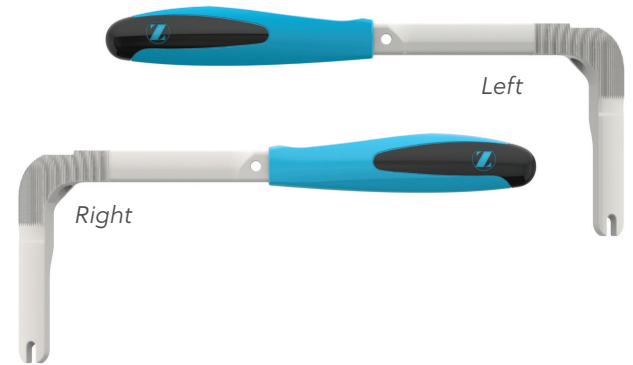


<b>Reduction Screw Tab Sleeve</b>	PART NUMBER
	730M0038



<b>Reduction Screw Tab Breaker</b>	PART NUMBER
	07.02074.001

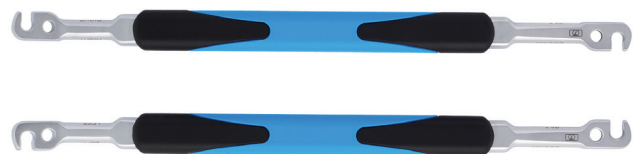
## In Situ Rod Bending



<b>Coronal Benders</b>	PART NUMBER
Left	730M0011
Right	730M0012



<b>Coronal Bender Fulcrum</b>	PART NUMBER
	730M0013



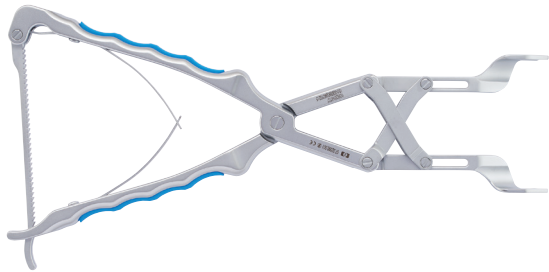
<b>Sagittal Benders</b>	PART NUMBER
Left - 5.5 mm	07.02091.001
Right - 5.5 mm	07.02091.002
Left - 6.0 mm	07.02102.001
Right - 6.0 mm	07.02102.002

## Instruments (continued)

### Rod Compression and Distraction



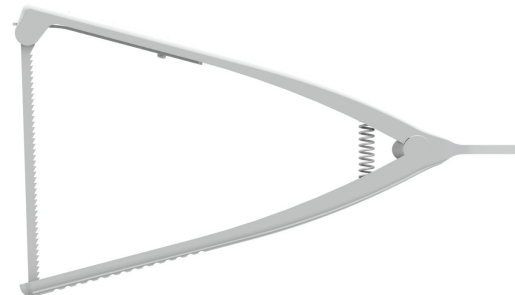
**Single-level Compressor - Parallel** PART NUMBER  
07.02089.001



**Multi-level Compressor - Parallel** PART NUMBER  
07.02090.001



**Single-level Distractor - Parallel** PART NUMBER  
07.02109.001



**Single-pivot Distractor** PART NUMBER  
730M0039

### Screw and Hook Final Tightening



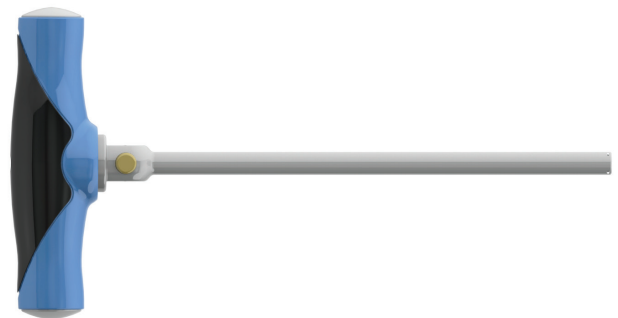
**T27 (Male) Final Driver** PART NUMBER  
730M0017



**Torque-limiting Handle 90 in-lb (10.17 Nm)** PART NUMBER  
07.02053.001



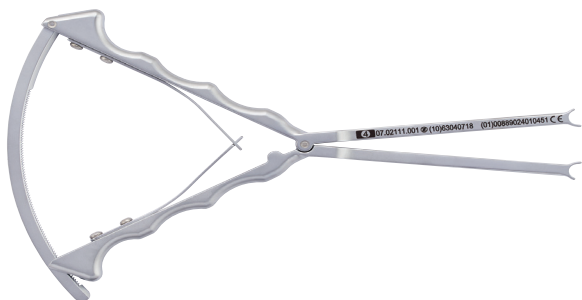
**Counter-torque** PART NUMBER  
730M0016



**Shear-Off Final Driver** PART NUMBER  
730M0002



### Transverse Connector Measurement, Insertion, and Final Tightening



**Caliper - Transverse Connector** PART NUMBER  
07.02111.001



**T20 Provisional Driver** PART NUMBER  
07.02119.001



**T20 Final Driver** PART NUMBER  
07.02063.001

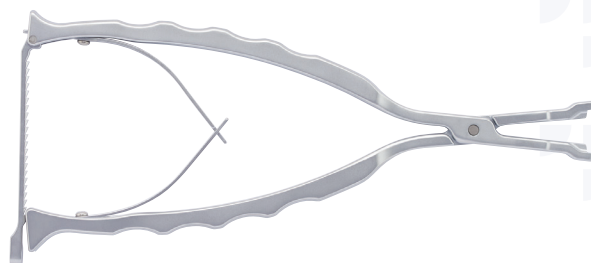


**Torque-limiting Handle 50 in-lb (5.65 Nm)** PART NUMBER  
07.02118.001



**Counter-torque - Transverse Connector** PART NUMBER  
07.02121.001

### Rod-to-Rod Connector Insertion



**Rod-to-Rod Connector Holder** PART NUMBER  
07.02123.001

### Screw and Closure Top Extraction

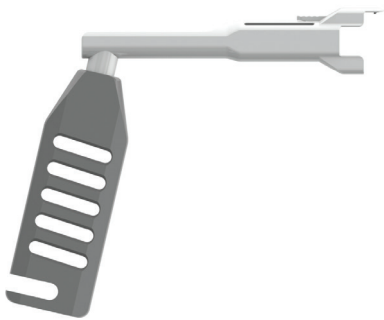


**T27 Easy Out Removal Driver** PART NUMBER  
07.02065.001

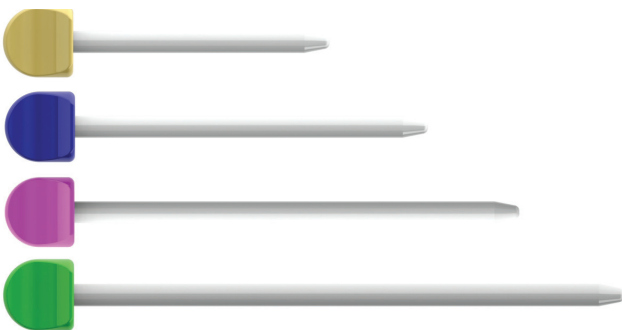
**Spinal Deformity Derotation**



**Derotator** PART NUMBER  
730M0000



**DeRoducer** PART NUMBER  
14-500204



**Linkage Rods** PART NUMBER

2-3 Handle Linkage Rod	14-501003
3-4 Handle Linkage Rod	14-501004
4-5 Handle Linkage Rod	14-501005
5-6 Handle Linkage Rod	730M0043



**Alignment Rods** PART NUMBER

25 cm Alignment Rod	14-501006
38 cm Alignment Rod	14-501007



**Combs** PART NUMBER

30 cm Comb	14-501008
36 cm Comb	14-501009



**Segmental Linkage** PART NUMBER  
730M0054



**Multilevel Linkage** PART NUMBER  
730M0053

## Optional Instruments



Small Awl	PART NUMBER
	07.02076.002



Pedicule Probes (Tear Drop Handle)	PART NUMBER
Lumbar - Straight	07.02067.001
Lumbar - Curved	07.02079.001
Lumbar - Straight Lenke	07.02077.001
Lumbar - Curved Lenke	07.02072.001



Pedicule Probes (Round Handle)	PART NUMBER
Thoracic - Straight	07.02080.001
Thoracic - Curved	07.02078.001
Iliac	07.02112.001



Ball-tip Probes	PART NUMBER
Single-ended, Stiff - Small	07.02082.001
Single-ended, Flexible - Small	07.02083.001
Dual-ended Stiff/Flexible - Small	07.02084.001
Single-ended, Flexible - Standard	07.02116.001



Taps	PART NUMBER
3.5 mm	07.02088.001
4.0 mm	07.02088.002
4.5 mm	07.02088.003
5.0 mm	07.02088.004
5.5 mm	07.02088.005
6.0 mm	07.02088.006
6.5 mm	07.02088.007
7.0 mm	07.02088.008
7.5 mm	07.02088.009
8.0 mm	07.02088.010
8.5 mm	07.02088.011
9.0 mm	07.02088.012
9.5 mm	07.02088.013
10.0 mm	07.02088.014
10.5 mm	07.02088.015



Iliac Taps	PART NUMBER
6.0 mm	07.02114.006
6.5 mm	07.02114.007
7.0 mm	07.02114.008
7.5 mm	07.02114.009
8.0 mm	07.02114.010
8.5 mm	07.02114.011
9.0 mm	07.02114.012
9.5 mm	07.02114.013
10.0 mm	07.02114.014
10.5 mm	07.02114.015



Pedicule Markers	PART NUMBER
Small Bulb	07.02085.001
Large Bulb	07.02086.001



**Screwdriver - multi-piece**

PART NUMBER

07.02087.001



**Screwdriver - Short**

PART NUMBER

07.02055.001



**Reduction Screwdriver - Short**

PART NUMBER

07.02128.001



**Screwdriver, Short - Cannulated**

PART NUMBER

730M0061



**Fixed Handle - Straight**

PART NUMBER

07.02106.001



**Fixed Handle - T-handle**

PART NUMBER

07.02107.001



**Fixed Handle - Palm**

PART NUMBER

07.02108.001



**Pivoting Axial Handle**

PART NUMBER

07.02130.001



**Alignment Tool**

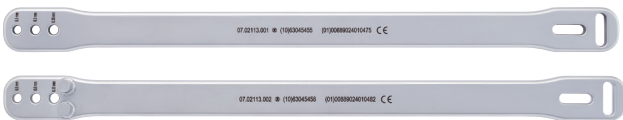
PART NUMBER

07.02094.001

## Optional Instruments (continued)



Multi-level Distractor - Parallel	PART NUMBER
	07.02110.001



Scoli Rod Benders	PART NUMBER
Left	07.02113.001
Right	07.02113.002



Removal Driver	PART NUMBER
	07.02061.001



Rod Templates	PART NUMBER
100 mm	07.02099.001
470 mm	07.02099.003



Pedicule Probes	PART NUMBER
Pedicule Probe - Lumbar Curved	730M1002
Pedicule Probe - Lumbar Straight Lenke	730M1003
Pedicule Probe - Thoracic Straight, Small	730M1008
Pedicule Probe - Thoracic Curved, Small	730M1009



Taps	PART NUMBER
4.0 mm (Gold)	730M3040
5.0 mm (Green)	730M3050
6.0 mm (Gold)	730M3060
7.0 mm (Magenta)	730M3070
8.0 mm (Dark Blue)	730M3080
9.0 mm (Magenta)	730M3090
9.5 mm (Light Blue)	730M3095
10.0 mm (Teal)	730M3100
10.5 mm (Purple)	730M3105
5.0 mm (Green), Cannulated	735M0150
6.0 mm (Gold), Cannulated	735M0160
7.0 mm (Magenta), Cannulated	735M0170
8.0 mm (Dark Blue), Cannulated	735M0180



Iliac Taps	PART NUMBER
6.0 mm (Gold) Cannulated Iliac Tap	730M5060
7.0 mm (Magenta) Cannulated Tap Iliac Tap	730M5070
8.0 mm (Dark Blue) Cannulated Tap Iliac Tap	730M5080
9.0 mm (Magenta) Cannulate Iliac Tap	730M5090
10.0 mm (Teal) Cannulated Iliac Tap	730M5100
10.5 mm (Purple) Cannulated Iliac Tap	730M5105



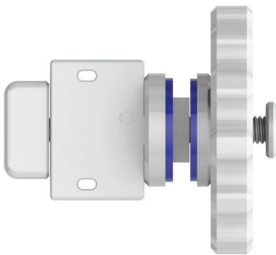
**Screwdriver Sleeve, Short** PART NUMBER  
07.02131.003



**Horizontalizer** PART NUMBER  
Small, 55 mm 14-500121  
Large, 75 mm 14-500122



**Medium Laminar Hook Starter** PART NUMBER  
730M0033



**Segmental Linkage, Threaded** PART NUMBER  
730M0064

## Important information on the Vitality Spinal Fixation System

### Vital

The Vital Spinal Fixation System is a subsystem of the Vitality Spinal Fixation System.

### Device Description

The Vitality Spinal Fixation System is a thoracolumbar and sacroiliac fixation system designed to aid in the surgical correction of several types of spinal conditions. The system consists of a variety of spinal rods, pedicle screws, hooks and connectors intended only to provide temporary stabilization during the development of a solid fusion of the spine with bone graft. The system can be rigidly locked into a variety of configurations, with each construct being customized to the patient's anatomy. All implants are single use only and should not be reused under any circumstances. The implant system is intended to be removed after solid fusion has occurred.

The system also includes instrumentation for insertion, securing and removal of the implants. All implants are made from medical grade titanium alloy; select rods are also available in medical grade cobalt chromium alloy. Implants made from medical grade titanium, medical grade titanium alloy, and medical grade cobalt chromium may be used together. Never use titanium, titanium alloy and/or cobalt chromium with stainless steel in the same implant construct. The Vitality Spinal Fixation System is compatible with components from other cleared spinal fixation systems. See Indications below.

### Indications

The Vitality Spinal Fixation System implants are non-cervical spinal fixation devices intended for posterior pedicle screw fixation (T1 S2/ilium), posterior hook fixation (T1 L5), or anterolateral fixation (T8 L5). Pedicle screw fixation is indicated for skeletally mature patients and for adolescent patients.

These devices are indicated as an adjunct to fusion for all of the following indications: degenerative disc disease (defined as discogenic back pain with degeneration of the disc confirmed by history and radiographic studies), spondylolisthesis, trauma (i.e., fracture

or dislocation), deformities or curvatures (i.e., scoliosis, kyphosis and/or lordosis, Scheuermann's Disease), tumor, stenosis, pseudoarthrosis and/or failed previous fusion. When used as an adjunct to fusion, the Vitality Spinal Fixation System is intended to be used with autograft and/or allograft.

In addition the Vitality Spinal Fixation System is intended for treatment of severe spondylolisthesis (Grade 3 and 4) of the L5–S1 vertebra in skeletally mature patients receiving fusion by autogenous bone graft, having implants attached to the lumbosacral spine and or ilium with removal of the implant after attainment of a solid fusion. Levels of pedicle screw fixation for these patients are L3-sacrum/ilium.

When used for posterior non-cervical pedicle screw fixation in pediatric patients, the Vitality System implants are indicated as an adjunct to fusion to treat adolescent idiopathic scoliosis. The Vitality System is intended to be used with autograft and/or allograft. Pediatric pedicle screw fixation is limited to a posterior approach.

The use of the Vitality Spinal Fixation System in skeletally mature patients may include the fixation of the Instinct® Java™ Spinal Fixation System\* hooks, APEX Spinal System™\* hooks, or fixation of the Universal Clamp® Spinal Fixation System\* to the rods of the Vitality Spinal Fixation System. The Vitality Spinal Fixation System may also be used in skeletally immature patients when connected with the Universal Clamp Spinal Fixation System.

In order to achieve additional levels of fixation in skeletally mature patients, the Vitality Spinal Fixation System may be connected to the Virage® OCT Spinal Fixation System\* and the Instinct Java Spinal Fixation System offered by ZimVie Spine, using rod connectors.

### Contraindications

The Vitality System is not designed or sold for any use except as indicated. **DO NOT USE THE VITALITY SYSTEM IMPLANTS IN THE PRESENCE OF ANY CONTRAINDICATION.**

- Insufficient bone quantity, severe osteoporosis or other condition that might compromise rigid fixation of the device.

\* These optional components are not approved in all regions.

- A history of infection, active systemic infection or infection localized to the site of the proposed implantation.
- Suspected or documented metal allergy or intolerance.
- A disorder affecting the normal process of bone remodeling, including but not limited to severe osteoporosis involving the spine, excessive bone reabsorption, osteopenia, a primary or metastatic tumor involving the spine or certain metabolic disorders of osteogenesis.
- Iliac screws and offset connectors should not be used in cases of tumor or trauma of the sacrum, when additional screw fixation in S1 is not possible.
- Other relative contraindications include obesity, pregnancy, certain degenerative diseases, and foreign body sensitivity. In addition, the patient's occupation or activity level or mental capacity may be relative contraindications to this surgery. Specifically, some patients may, because of their occupation or lifestyle, or because of conditions such as mental illness, alcoholism or drug abuse, place undue stresses on the implant
- Universal precautions should be observed by all end users that work with contaminated or potentially contaminated medical devices. Caution should be exercised when handling devices with sharp points or cutting edges to prevent injuries during and after surgical procedures and reprocessing.
- Warning: The safety and effectiveness of pedicle screw spinal systems have been established only for spinal conditions with significant mechanical instability or deformity requiring fusion with instrumentation. These conditions are significant mechanical instability or deformity of the thoracic, lumbar and sacral spine secondary to severe spondylolisthesis (grades 3 and 4) of the L5–S1 vertebra, degenerative spondylolisthesis with objective evidence of neurological impairment, fracture, dislocation, scoliosis, kyphosis, spinal tumor and failed previous fusion (pseudoarthrosis). The safety and effectiveness of these devices for any other conditions are unknown.
- Warning: The safety and effectiveness of this device has not been established for use as part of a growing rod construct. The device is only intended to be used when definitive fusion is being performed at all instrumented levels.

### Warnings and Precautions

Following are specific warnings, precautions and adverse effects associated with use of the Vitality System that should be understood by the surgeon and explained to the patients. General surgical risk should be explained to the patients prior to surgery.

- Implantation of the Vitality System should be performed only by experienced spinal surgeons.
- All implants are intended for single use only. Single-use devices should not be re-used. Possible risks associated with re-use of single-use devices include:
  - Mechanical malfunction
  - Transmission of infectious agents
- Metal sensitivity has been reported following exposure to orthopedic implants. The most common metallic sensitivities (nickel, cobalt and chromium) are present in medical grade stainless steel and cobalt-chrome alloys.
- Additional Warnings for Pediatric Patients: The use of pedicle screw fixation in the pediatric population may present additional risks when patients are of smaller stature and skeletally immature. Pediatric patients may have smaller spinal structures (pedicle diameter or length) that may preclude the use of pedicle screws or increase the risk of pedicle screw malpositioning and neurological or vascular injury. Patients who are not skeletally mature undergoing spinal fusion procedures may have reduced longitudinal spinal growth, or may be at risk for rotational spinal deformities (the "crankshaft phenomenon") due to continued differential growth of the anterior spine.
- Precaution: The implantation of pedicle screw spinal systems should be performed only by experienced spinal surgeons with specific training in the use of this pedicle screw spinal system because this is a technically demanding procedure presenting a risk of serious injury to the patient.



## Important information on the Vitality Spinal Fixation System (continued)

- Additional Precautions for Pediatric Patients: The implantation of pedicle screw spinal systems in pediatric patients should be performed only by experienced spinal surgeons with specific training in the use of this pedicle screw spinal system in pediatric patients because this is a technically demanding procedure presenting a risk of serious injury to the patient.

Preoperative and operating procedures, including knowledge of surgical techniques, good reduction, and proper selection and placement of the implants are important considerations in the successful utilization of the system in pediatric patients. The selection of the proper size, shape and design of the implant for each patient is crucial to the safe use of this device in pediatric patients.

Additional preoperative, intraoperative and postoperative warnings and precautions:

### Preoperative

- Usage of automated cleaning processes without supplemental manual cleaning may not result in adequate cleaning of instruments.
- Proper handling, decontamination (including pre-rinsing, washing, rinsing and sterilization), storage and utilization are important for the long and useful life of all surgical instruments. Even with correct use, care and maintenance, they should not be expected to last indefinitely. This is especially true for cutting instruments (e.g., bone awls/drills) and driving instruments (e.g., drivers). These items are often subjected to high loads and/or impact forces. Under such conditions, breakage can occur, particularly when the item is corroded, damaged, nicked or scratched.
- Never use titanium, titanium alloy, and/or cobalt chromium with stainless steel in the same implant construct; otherwise, galvanic corrosion may occur.
- ZimVie does not specify the maximum number of times a re-usable instrument may be re-used. The useful life of these instruments is highly dependent on a number of factors including the frequency and manner in which they are used and the handling they experience in between uses. Inspection and, where appropriate, functional testing prior to using, is the best way to determine whether or not an individual device should be used.

### Intraoperative

- If contouring of the implant is necessary for optimal fit, the contouring should be gradual and avoid any notching or scratching of the implant surface. Do not repeatedly or excessively bend the implant. Do not reverse bend the rods.
- Pedicle bone integrity should be verified.
- Care should be taken during pedicle preparation to avoid penetrating too deep.
- Care should be taken during bone preparation to avoid damage to the pedicle and to the surgical instruments.
- Care should be taken to minimize soft tissue damage during surgery.
- Care should be taken to avoid removing excess material from the lamina.
- Care should be taken to avoid cross-threading screws and closure tops.
- If any implant or instrument comes in contact with a non-sterile surface it should not be used.

### Postoperative

- Adequately instruct the patient. Postoperative care and the patient's ability and willingness to follow instructions are one of the most important aspects of successful bone healing. The patient must be made aware of the limitations of the implant and that physical activity and full weight bearing have been implicated in fracture. The patient should understand that an implant is not as strong as normal, healthy bone and will fracture if excessive demands are placed on it in the absence of complete bone healing. An active, debilitated, or demented patient who cannot properly use weight-supporting devices may be particularly at risk during postoperative rehabilitation.
- The Vitality System is a temporary internal fixation device. Internal fixation devices are designed to stabilize the operative site during the normal healing process. After healing occurs, these devices serve no functional purpose and should be removed. Implant removal should be followed by adequate postoperative management to avoid fracture or refracture.

## Adverse Effects

Complications and adverse reactions have been reported with the use of similar spinal instrumentation systems. These adverse effects, including the possibility of death, should be discussed with the patient prior to surgery.

- Non-union, delayed union
  - Bending or fracture of implant. Fraying, kinking, loosening, bending or breaking of any or all implant components.
  - Loosening of or migration of the implant
  - Metal sensitivity or allergic reaction to a foreign body
  - Infection
  - Decrease in bone density due to stress shielding
  - Pain, discomfort, or abnormal sensations due to the presence of the device
  - Loss of the natural curvature of the spine
  - Modification of the spinal geometric corrections of the vertebral and/or intervertebral height and/or of the reduction in spinal deformities
  - Vascular and/or nerve damage due to surgical trauma or presence of the device.
  - Neurological difficulties including bowel and/or bladder dysfunction, impotence, retrograde ejaculation and paraesthesia.
  - Bursitis
  - Dural leak
  - Paralysis
  - Death
  - Erosion of blood vessels due to the proximity of the device, leading to hemorrhage and/or death
  - Additional surgery may be required to correct any of these potential adverse effects
- Additional Potential Adverse Effects for Pediatric Patients:
    - Inability to use pedicle screw fixation due to anatomic limitations (pedicle dimensions, distorted anatomy)
    - Pedicle screw malpositioning, with or without neurological or vascular injury
    - Proximal or distal junctional kyphosis
    - Pancreatitis

Other adverse events related to pedicle screw fixation, such as screw or rod bending, breakage, or loosening, may also occur in pediatric patients and pediatric patients may be at increased risk for device-related injury because of their smaller stature.

## Important information on the Vitality Spinal Fixation System (continued)

### Vital™ Power

The Vital™ Power Instrument System is a subsystem of the Vitality Spinal Fixation System.

### Description

The Vitality Spinal Fixation System is a thoracolumbar and sacroiliac fixation system designed to aid in the surgical correction of several types of spinal conditions. The system consists of a variety of spinal rods, pedicle screws, hooks and connectors intended only to provide temporary stabilization during the development of a solid fusion of the spine with bone graft. The system can be rigidly locked into a variety of configurations, with each construct being customized to the patient's anatomy. All implants are single use only and should not be reused under any circumstances. The implant system is intended to be removed after solid fusion has occurred.

The system also includes instrumentation for insertion, securing and removal of the implants. All implants are made from medical grade titanium alloy; select rods are also available in medical grade cobalt chromium alloy. Implants made from medical grade titanium, medical grade titanium alloy, and medical grade cobalt chromium may be used together. Never use titanium, titanium alloy, and/or cobalt chromium with stainless steel in the same implant construct. The Vitality Spinal Fixation System is compatible with components from other cleared spinal fixation systems. See Indications below.

### Intended Use (Power)

Vital Power instruments and adapters are intended for use with the Zimmer Biomet Universal Power System to facilitate the preparation of the pedicle and ilium and insertion of Vitality Spinal Fixation System screws using a power surgical technique. Pedicle and iliac screws from the Vitality Spinal Fixation System may be implanted in the non-cervical spine using powered instrumentation during spinal surgery, including open and minimally invasive procedures.

### Indications (Power)

The Vitality Spinal Fixation System implants are non-cervical spinal fixation devices intended for posterior pedicle screw fixation (T1-S2/ilium), posterior hook fixation (T1-L5), or anterolateral fixation (T8-L5). Pedicle screw fixation is indicated for skeletally mature patients and for adolescent patients. These devices are indicated as an adjunct to fusion for all of the following indications: degenerative disc disease (defined as discogenic back pain with degeneration of the disc confirmed by history and radiographic studies), spondylolisthesis, trauma (i.e., fracture or dislocation), deformities or curvatures (i.e. scoliosis, kyphosis, and/or lordosis, Scheuermann's Disease), tumor, stenosis, pseudoarthrosis and/or failed previous fusion. When used as an adjunct to fusion, the Vitality Spinal Fixation System is intended to be used with autograft and/or allograft

In addition the Vitality Spinal Fixation System is intended for treatment of severe spondylolisthesis (Grade 3 and 4) of the L5-S1 vertebra in skeletally mature patients receiving fusion by autogenous bone graft, having implants attached to the lumbosacral spine and or ilium with removal of the implant after attainment of a solid fusion. Levels of pedicle screw fixation for these patients are L3-sacrum/ilium.

When used for posterior non-cervical pedicle screw fixation in pediatric patients, the Vitality System implants are indicated as an adjunct to fusion to treat adolescent idiopathic scoliosis. The Vitality System is intended to be used with autograft and/or allograft. Pediatric pedicle screw fixation is limited to a posterior approach.

The use of the Vitality Spinal Fixation System in skeletally mature patients may include the fixation of the Instinct® Java™ Spinal Fixation System\* hooks, APEX Spinal System™\* hooks, or fixation of the Universal Clamp® Spinal Fixation System\* to the rods of the Vitality Spinal Fixation System. The Vitality Spinal Fixation System may also be used in skeletally immature patients when connected with the Universal Clamp Spinal Fixation System.

In order to achieve additional levels of fixation in skeletally mature patients, the Vitality Spinal Fixation System\* may be connected to the Virage® OCT Spinal Fixation System and the Instinct Java Spinal Fixation System offered by Zimmer Biomet Spine, using rod connectors.

## Contraindications

The Vitality System is not designed or sold for any use except as indicated. Do not use the vitality system implants in the presence of any contraindication.

- Insufficient bone quantity, severe osteoporosis, or other condition that might compromise rigid fixation of the device.
- A history of infection, active systemic infection or infection localized to the site of the proposed implantation.
- Suspected or documented metal allergy or intolerance.
- A disorder affecting the normal process of bone remodelling, including but not limited to severe osteoporosis involving the spine, excessive bone reabsorption, osteopenia, a primary or metastatic tumor involving the spine, or certain metabolic disorders of osteogenesis.
- Iliac screws and offset connectors should not be used in cases of tumor or trauma of the sacrum, when additional screw fixation in S1 is not possible.

Other relative contraindications include obesity, pregnancy, certain degenerative diseases, and foreign body sensitivity. In addition, the patient's occupation or activity level or mental capacity may be relative contraindications to this surgery. Specifically, some patients may, because of their occupation or lifestyle, or because of conditions such as mental illness, alcoholism or drug abuse, place undue stresses on the implant.

## Warnings and Precautions

Following are specific warnings, precautions, and adverse effects associated with use of the Vitality System that should be understood by the surgeon and explained to the patients. General surgical risk should be explained to the patients prior to surgery.

- Implantation of the Vitality System should be performed only by experienced spinal surgeons.
- All implants are intended for single use only. Single use devices should not be re-used. Possible risks associated with re-use of single-use devices include:
  - Mechanical malfunction
  - Transmission of infectious agents

- Metal sensitivity has been reported following exposure to orthopedic implants. The most common metallic sensitivities (nickel, cobalt, and chromium) are present in medical grade stainless steel and cobalt-chrome alloys.
- Universal precautions should be observed by all end users that work with contaminated or potentially contaminated medical devices. Caution should be exercised when handling devices with sharp points or cutting edges to prevent injuries during and after surgical procedures and reprocessing.
- Warning: The safety and effectiveness of pedicle screw spinal systems have been established only for spinal conditions with significant mechanical instability or deformity requiring fusion with instrumentation. These conditions are significant mechanical instability or deformity of the thoracic, lumbar, and sacral spine secondary to severe spondylolisthesis (grades 3 and 4) of the L5-S1 vertebra, degenerative spondylolisthesis with objective evidence of neurological impairment, fracture, dislocation, scoliosis, kyphosis, spinal tumor, and failed previous fusion (pseudoarthrosis). The safety and effectiveness of these devices for any other conditions are unknown.
- Warning: The safety and effectiveness of this device has not been established for use as part of a growing rod construct. The device is only intended to be used when definitive fusion is being performed at all instrumented levels.
- Additional Warnings for Pediatric Patients: The use of pedicle screw fixation in the pediatric population may present additional risks when patients are of smaller stature and skeletally immature. Pediatric patients may have smaller spinal structures (pedicle diameter or length) that may preclude the use of pedicle screws or increase the risk of pedicle screw malpositioning and neurological or vascular injury. Patients who are not skeletally mature undergoing spinal fusion procedures may have reduced longitudinal spinal growth, or may be at risk for rotational spinal deformities (the "crankshaft phenomenon") due to continued differential growth of the anterior spine.

## Important information on the Vitality Spinal Fixation System (continued)

- Precaution: The implantation of pedicle screw spinal systems should be performed only by experienced spinal surgeons with specific training in the use of this pedicle screw spinal system because this is a technically demanding procedure presenting a risk of serious injury to the patient.
- Additional Precautions for Pediatric Patients: The implantation of pedicle screw spinal systems in pediatric patients should be performed only by experienced spinal surgeons with specific training in the use of this pedicle screw spinal system in pediatric patients because this is a technically demanding procedure presenting a risk of serious injury to the patient.

Additional preoperative, intraoperative, and postoperative warnings and precautions:

### Preoperative

- Usage of automated cleaning processes without supplemental manual cleaning may not result in adequate cleaning of instruments.
- Proper handling, decontamination (including pre-rinsing, washing, rinsing and sterilization), storage and utilization are important for the long and useful life of all surgical instruments. Even with correct use, care and maintenance, they should not be expected to last indefinitely. This is especially true for cutting instruments (e.g., bone awls/drills) and driving instruments (e.g., drivers). These items are often subjected to high loads and/or impact forces. Under such conditions, breakage can occur, particularly when the item is corroded, damaged, nicked or scratched.
- Never use titanium, titanium alloy, and/or cobalt chromium with stainless steel in the same implant construct; otherwise, galvanic corrosion may occur.
- Zimmer Biomet does not specify the maximum number of times a re-usable instrument may be re-used. The useful life of these instruments is highly dependent on a number of factors including the frequency and manner in which they are used and the handling they experience in between uses. Inspection and, where appropriate, functional testing prior to using, is the best way to determine whether or not an individual device should be used.

Prior to use, instruments should be visually inspected for wear and tested to assure they are functioning properly. If instruments are discolored, show evidence of corrosion, have loose screws/pins, are out of alignment, are cracked or have other irregularities, DO NOT USE. Instrumentation that appears damaged should be returned to the manufacturer.

### Intraoperative

- If contouring of the implant is necessary for optimal fit, the contouring should be gradual and avoid any notching or scratching of the implant surface. Do not repeatedly or excessively bend the implant. Do not reverse bend the rods.
- Pedicle bone integrity should be verified.
- Care should be taken during pedicle preparation to avoid penetrating too deep.
- Care should be taken during bone preparation to avoid damage to the pedicle and to the surgical instruments.
- Care should be taken to minimize soft tissue damage during surgery.
- Care should be taken to avoid removing excess material from the lamina.
- Care should be taken to avoid cross-threading screws and closure tops.
- If any implant or instrument comes in contact with a non-sterile surface it should not be used.

### Postoperative

- Adequately instruct the patient. Postoperative care and the patient's ability and willingness to follow instructions are one of the most important aspects of successful bone healing. The patient must be made aware of the limitations of the implant and that physical activity and full weight bearing have been implicated in fracture. The patient should understand that an implant is not as strong as normal, healthy bone and will fracture if excessive demands are placed on it in the absence of complete bone healing. An active, debilitated, or demented patient who cannot properly use weight-supporting devices may be particularly at risk during postoperative rehabilitation.

- The Vitality System is a temporary internal fixation device. Internal fixation devices are designed to stabilize the operative site during the normal healing process. After healing occurs, these devices serve no functional purpose and should be removed. Implant removal should be followed by adequate postoperative management to avoid fracture or refracture.

### Adverse Effects

Complications and adverse reactions have been reported with the use of similar spinal instrumentation systems. These adverse effects, including the possibility of death, should be discussed with the patient prior to surgery.

- Non-union, delayed union
- Bending or fracture of implant. Fraying, kinking, loosening, bending or breaking of any or all implant components.
- Loosening of or migration of the implant
- Metal sensitivity or allergic reaction to a foreign body
- Infection
- Decrease in bone density due to stress shielding
- Pain, discomfort, or abnormal sensations due to the presence of the device
- Loss of the natural curvature of the spine
- Modification of the spinal geometric corrections of the vertebral and/or intervertebral height and/or of the reduction in spinal deformities
- Vascular and/or nerve damage due to surgical trauma or presence of the device.
- Neurological difficulties including bowel and/or bladder dysfunction, impotence, retrograde ejaculation and paraesthesia.
- Bursitis
- Dural leak
- Paralysis
- Death
- Erosion of blood vessels due to the proximity of the device, leading to hemorrhage and/or death

- Additional surgery may be required to correct any of these potential adverse effects
- Additional Potential Adverse Effects for Pediatric Patients:
  - Inability to use pedicle screw fixation due to anatomic limitations (pedicle dimensions, distorted anatomy)
  - Pedicle screw malpositioning, with or without neurological or vascular injury
  - Proximal or distal junctional kyphosis
  - Pancreatitis

Other adverse events related to pedicle screw fixation, such as screw or rod bending, breakage, or loosening, may also occur in pediatric patients and pediatric patients may be at increased risk for device-related injury because of their smaller stature.

For more information, visit [ZimVie.com](http://ZimVie.com)



**Manufactured by:**  
Zimmer Biomet Spine, Inc.  
10225 Westmoor Dr.  
Westminster, CO 80021 USA  
[ZimVie.com](http://ZimVie.com)



Biomet 3i Dental Iberica, S.L.U  
WTC Almeda Park, Edif. 4, Planta 2  
Tirso de Molina, 40  
08940 Cornellà de Llobregat  
Barcelona, Spain  
+900 800 303



**Disclaimer:** This document is intended exclusively for physicians and is not intended for laypersons. Distribution to any other recipient is prohibited. Information on the products and procedures contained in this document is of a general nature and does not represent and does not constitute medical advice or recommendations. Because this information does not purport to constitute any diagnostic or therapeutic statement with regard to any individual medical case, each patient must be examined and advised individually, and this document does not replace the need for such examination and/or advice in whole or in part.

**Caution:** Federal (USA) law restricts this device to sale by or on the order of a physician. Rx only. Please refer to the package inserts for important product information, including, but not limited to, indications, contraindications, warnings, precautions, adverse effects, and patient counseling information.

**eLabeling:** The Instructions for Use can be accessed online by visiting the website shown below. Additional languages are also available in electronic format for download. To request a paper copy of the Instructions for Use, contact ZimVie Spine at the phone number provided.

Consult Instructions for Use on this website <http://labeling.zimvie.com>

Unless otherwise indicated, as referenced herein, all trademarks and intellectual property rights are the property of ZimVie Inc. or an affiliate; and all products are manufactured by one or more of the spinal subsidiaries of ZimVie Inc. (Zimmer Biomet Spine, Inc., Zimmer Spine, LDR Medical, etc.) and marketed and distributed by Zimmer Biomet Spine and its authorized marketing partners. Please refer to the Instructions for Use and the package label for the products to be used with this Surgical Technique. Product clearance and availability may be limited to certain countries/regions. This material is intended for clinicians only and does not comprise medical advice or recommendations. Distribution to any other recipient is prohibited. This material may not be copied or reprinted without the express written consent of ZimVie. 2632.5-GLBL-EN-2024.01

©2024 ZimVie Inc. All rights reserved.

